

PF1007

Pressure Balance Valve Only



Product Features

- Pressure balance valve
- Ceramic disc cartridge
- Plaster guard included
- With intergral stops
- IPS and sweat connections
- 100% factory pressure tested
- Back-to-back capability
- Temperature limiting device
- Forged brass body
- Compatible with trim options
PF7658, PF7656, PF7654, PF7603



PF1007

Parts Available

- PF1007EXTCP** Valve extension (chrome plated) for PF1007
- PF1007EXTBN** Valve extension (brushed nickel) for PF1007
- PF1007EXTRB** Valve extension (oil-rubbed bronze) for PF1007
- PF1007TW** Thin wall installation kit for PF1007
- PF1007CRT** Replacement cartridge assembly

Product Specifications

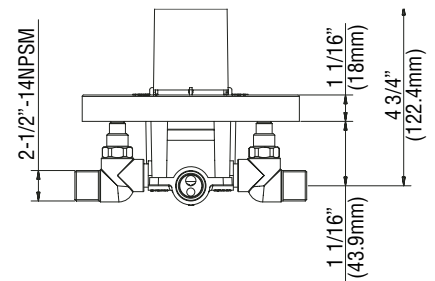
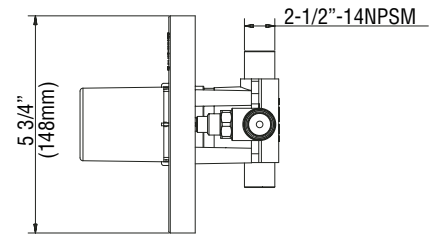
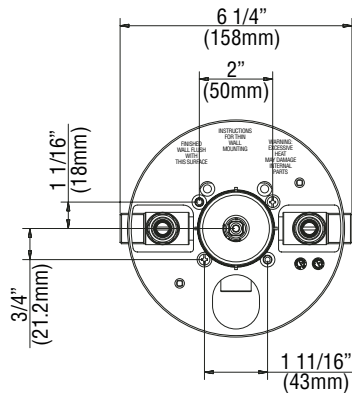

Warranty and Codes

This product comes complete with installation, operating, care and maintenance instructions. This PROFLO product carries a limited lifetime warranty. This product meets ANSI: A112.18.1M.



Distributed Exclusively by Ferguson and Wolseley Canada