



In-Wall Tank and Bowl Carrier System

With Dual Flush Technology

Geberit Model No.: 111.335.00.5

Flush Volume: 1.6 / 0.8 GPF - 6.0 / 3.0 LPF

D23924-003&BDC © 08-2009



cUPC®

Product Data

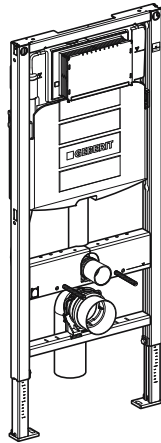

Product Specifications

Concealed tank and bowl carrier, wall-hung two-hole toilet bowl and actuator plate.

Tank and carrier system shall fit within standard 2 x 6 wall studs placed 19 3/4" (500) apart, water supply shall be 1/2" copper, minimum water pressure 35 PSI. The bowl shall be an IAMPO listed 1.6 gallon (6 l) per flush wall-hung bowl. The carrier shall have adjustable height for 15" (381) to 19" (483) bowl rim height. Actuator plates shall be die-cast zinc, plastic or stainless steel and plated to preserve the material's integrity.

Features

- Square structural 16 gauge powder coated steel frame
- Water consumption - Dual flush system allows for 0.8 GPF (3 l) or 1.6 GPF (6 l)
- Actuator dimension: 9 5/8" (254) width
6 1/2" (165) height
- Carrier height adjustable range 15" (381) to 19" (483) bowl rim height
- Impact resistant high density polyethylene tank HDPE
- Insulated to prevent condensation
- Anti-siphon fill valve meets ANSI / ASSE 1002-99 standard

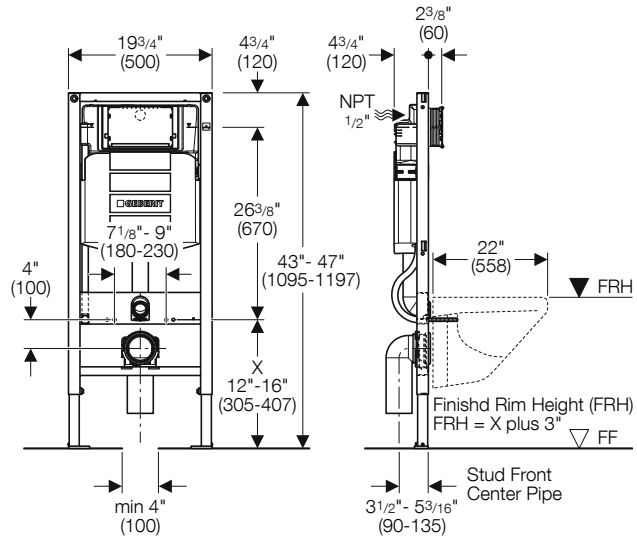
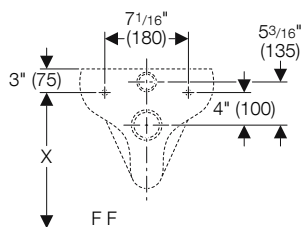

Material Determination



Recommended material for wall surface construction:

- Gypsum / green board
- Cement board
- Tile backer board
- Ceramic tile surface



Wall thickness not to exceed 3"

Options

	Samba Dual flush actuator; white	115.770.11.1
	Samba Dual flush actuator; chrome	115.770.21.1
	Rumba Single flush actuator; white	115.750.11.1
	Rumba Single flush actuator; chrome	115.750.21.1
	Tango Single flush actuator; chrome	115.760.21.1

Vertical discharge elbow 3" DWV standard

- Horizontal left: 366.914.16.1
- Horizontal right: 366.913.16.1

Warranty

Limited lifetime warranty on tank and carrier.
10 year warranty on fill valve and flush valve.
One year warranty on actuator plate.

Standards

In compliance with
- ASME 112.19.6
- ASME 112.6.2
- ASSE 1002
- CSA B125-98

Installation

Installation Requirements

To install tank and carrier, a 2 x 6" wood frame or metal frame construction is required. Studs must be placed 19 3/4" apart (clearance) where carrier will be positioned inside the wall.

Bowl Finished Rim Height (FRH)

Remove carrier and installation hardware from its box. Determine FRH for wall-hung bowl and adjust carrier height in accordance with requirement. Dimensions can be taken from bowl or carrier specification sheet. Be sure to allow for finished floor and sole plate height.

Discharge Elbow Installation



3 1/2" - 4 3/4"
(90-120)

4 1/8" - 5 3/16"
(105-135)

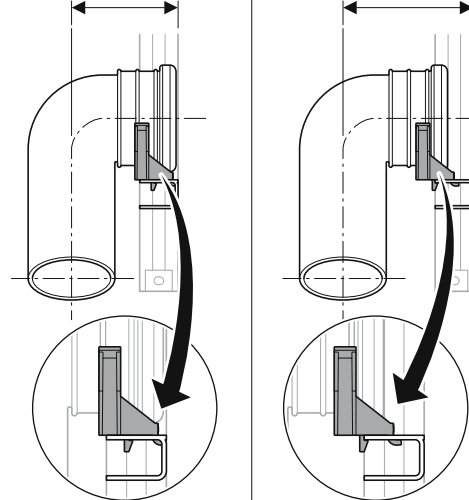

1

3 1/2" - 4 3/4"
(90-120)

4 1/8" - 5 3/16"
(105-135)

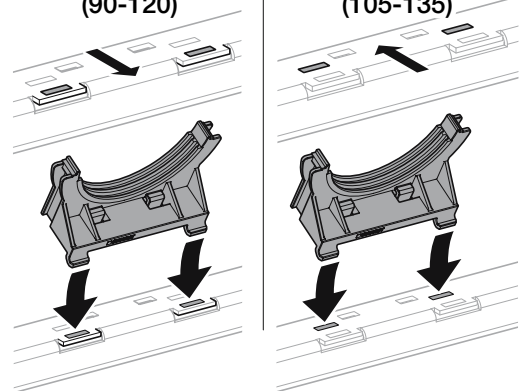

2

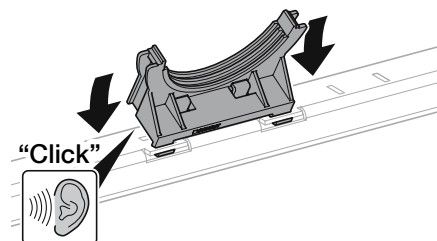

3

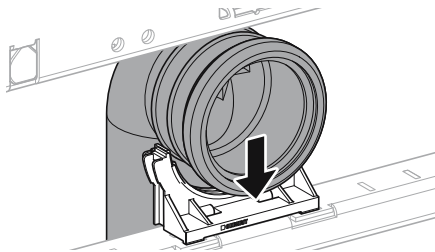
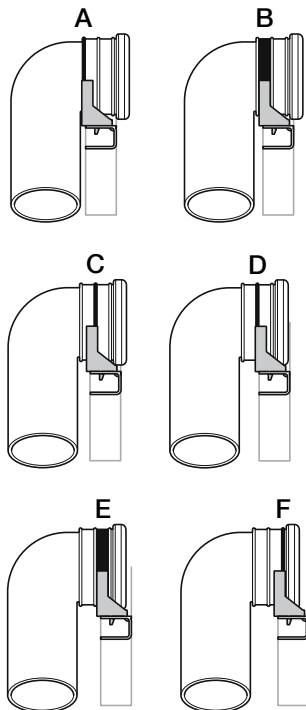

4

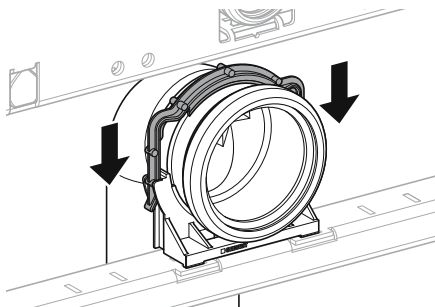

Tank and Carrier Installation

- 1 Locate carrier supporting studs and reinforce with additional nails. Ensure rough-in for the carrier is plumb and square. Wall framework must be affixed to the floor and ceiling for maximum support.
- 2 Position carrier unit in the prepared opening. Carrier face plate must be flush with the front of the surrounding studs so that maximum support for the wall sheeting (applied later) will be accomplished. With carrier still in place, mark all anchor and bolt hole locations on sole plate and studs. Mark location for the 3" DWV discharge pipe. With unit still in place, establish location for the water supply NPT elbow for rear inlet connection.
- 3 Pull out carrier from framework and drill six (6) pilot holes (3/16") for the supplied lag screws where marked on sole plate. Also drill six (6) bolt holes (5/16") where marked on both studs. Use hole saw and bore a 4" hole through sole plate and floor for the discharge stop out pipe. Provide and position support for the drop ear elbow (provided) for rear water supply. Extend elbow supply side with 1/2" x 6" copper tube and secure to support bracket.
- 4 Install 3" DWV waste pipe through floor and connect to waste line (i.e. PVC, copper, cast iron).
- 5 Set carrier unit back into framework and bolt in place with hardware provided.
- 6 Complete waste elbow connection with 3" DWV shielded coupling (D - provided) to waste pipe. Install supply stop valve into NPT 1/2" elbow, keep valve closed.
- 7 Install two (2) 1/2" x 6" fixture support rods with plastic sleeves (A), yellow pipe caps (B) and mud guard (C) for protection during wall surface construction.
- 8 Install wall surface material such as high density Gypsum / green Board, Cement Board, Tile Backer Board with optional ceramic tile finish surface as the most suitable materials. Provide cut outs for the protruding parts like rods, inlet and outlet pipes and the rectangular access box.

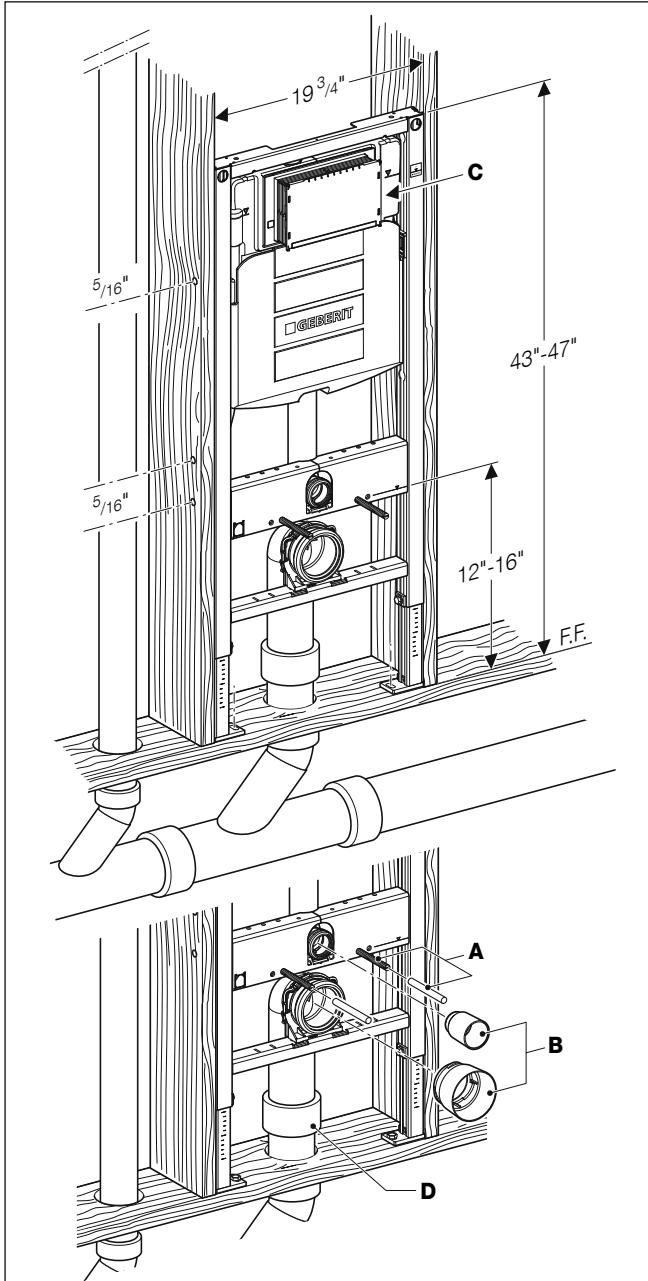

- A** Install 1/2" rods with plastic sleeves,
- B** pipe plugs and
- C** mud guard during the rough-in installation
- D** Complete waste elbow connection with 3" DWV shielded coupling (D - provided) to waste pipe.

i For finishing the installation of bowl and actuator plate see detailed instructions.

Bowl Installation

- 1** Remove yellow protection plugs and seals from pipes.

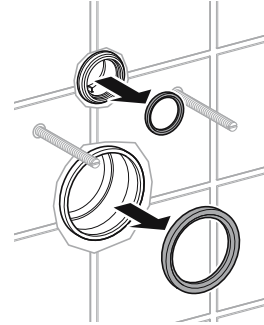

- 2** Insert discharge pipe into the pipe hub in the wall. Place a straight edge flush against the wall and mark a line on the pipe. Fit finned rubber seal onto flush pipe. Repeat same procedure for discharge pipe.

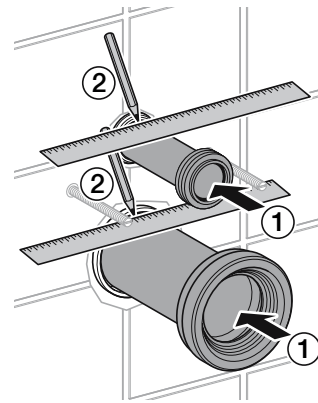

- 3** Place discharge pipe with gasket into waste outlet of bowl. Also place flush pipe with fin gasket into inlet of bowl. Then mark a second line on both pipes.

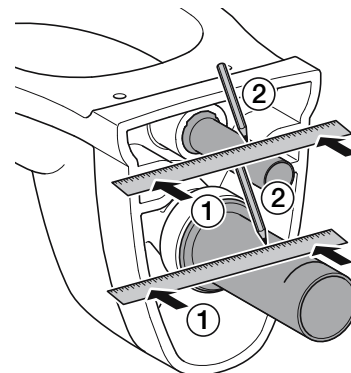

- 4** Add dimension X and 1/8". Using that dimension, mark a line on the pipe measuring from the hub side. Cut off the pipe at the line with a pipe cutter.

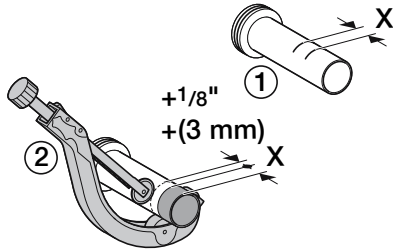

- 5** Add dimension Y and 1/8". Using that dimension, mark a line on the pipe measuring from the hub side. Cut off the pipe at the line with a pipe cutter.

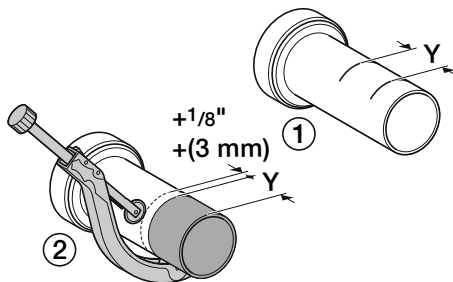

- 6** Bevel the sharp edges as shown to assure a smooth insertion into the pipe hubs in the wall.

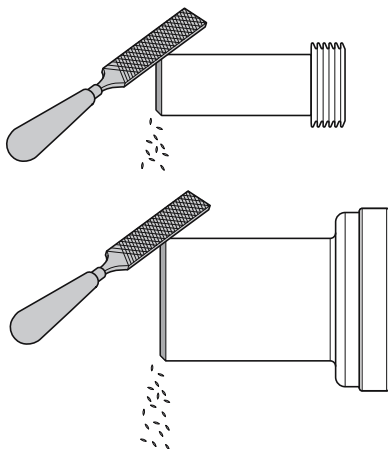

- 7** Install both seals into the pipes in the wall. Lubricate seals with appropriate rubber seal lubricant.

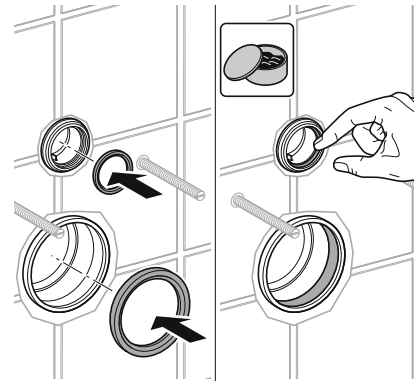

- 8** Remove protective sleeves from mounting rods. Determine protruding rod length for bowl installation. Install both pipes into the hubs in the wall.

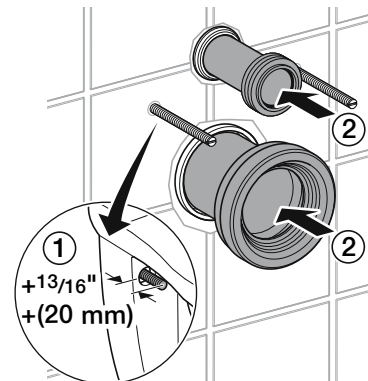

- 9** **NOTICE**
DO NOT overtighten hex nuts!

Place bowl onto rods. Attach cap washer with nose up and facing forwards onto rods. Install washer and hex nuts, tighten loosely. Level bowl. Tighten hex nuts. Snap on the bolt caps.

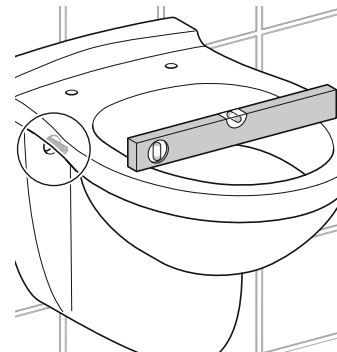

i Sound insulation pad is optional or required.

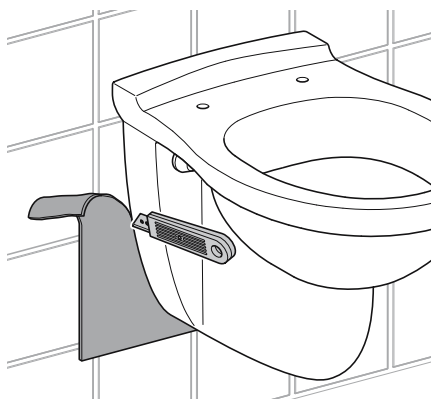
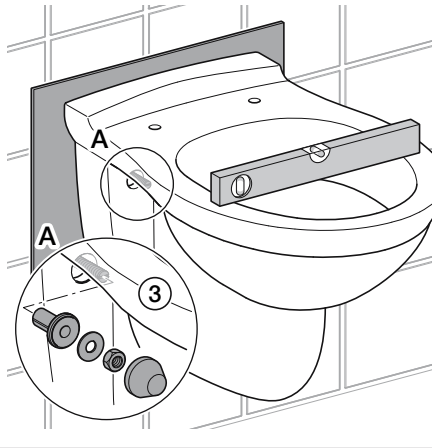
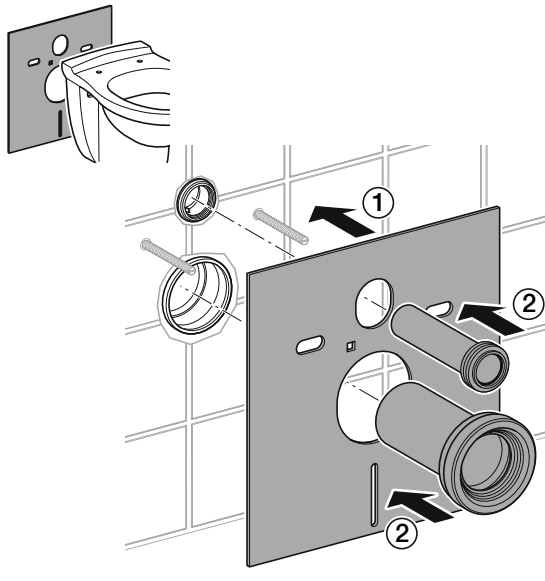

10 Seal gap around bowl with waterproof sealant.

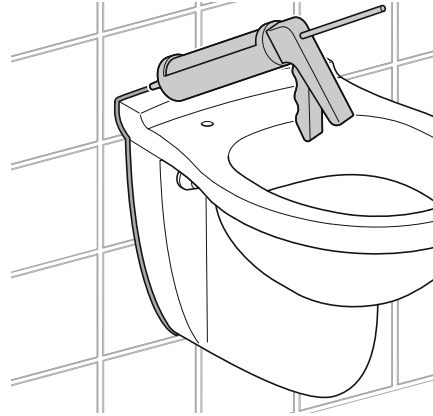

Service

Troubleshooting

PROBLEM	POSSIBLE CAUSE	POSSIBLE SOLUTION
WATER CONTINUES TO RUN AFTER FLUSH CYCLE IS COMPLETED	Flush valve is not seated properly.	Remove actuator plate or access panel to reach flush valve. Press valve down to ensure complete seal.
	Water runs into overflow tube; the water level is too high in tank.	Remove actuator or access panel. Turn spindle counterclockwise to lower water level in tank.
	Water is leaking from fill valve.	Remove actuator or access panel. Check connection.
WASTE IS NOT REMOVED FROM BOWL	Water level is too low in tank; flush is less than 1.6 gallons.	Remove actuator or access panel. Turn spindle clockwise to increase water level in tank.
	Bowl or sewer line is clogged.	If bowl trap is clogged, plunge toilet. If no result, snake as needed.
BOWL MOVES DOWN WHEN WEIGHT IS APPLIED	Bowl to wall installation has come loose with use.	Tighten nuts to tighten bowl firmly to wall.
	Improper wall surface used to mount bowl. Gypsum / green board, cement board, tile backer board or ceramic tile surface are recommended materials for mounting.	Remove bowl and install one of recommended surfaces on wall. Remount bowl.
SYSTEM SHUTS OFF BEFORE CYCLE IS COMPLETED	Flush rod is improperly installed.	Remove actuator. Adjust rod length. See pictures of instructions.

CHICAGO FAUCETS Warranty / GEBERIT Brand Product

In-Wall Tank and Bowl Carrier System

Chicago Faucets will either replace or repair the defective equipment or refund the purchase price, at its option, if an inspection by Chicago Faucets or its authorized representative discloses any manufacturing defects in material or workmanship. During this period Chicago Faucets will not be liable for any labor or other expenses not specifically stated above and disclaims any responsibility for incidental or consequential damages. Warranties implied by law, including that of merchantability, are expressly limited to the period of this warranty. This limitation and exclusion does not apply in those states that do not allow limitations on the duration of implied warranties. Or the exclusion may not apply to you. This warranty gives you specific legal rights and you may have other rights, which vary from state to state.

Contact

CHICAGO FAUCETS Company
 2100 Clearwater Drive, Des Plaines, IL 60018-5999
 www.chicagofaucets.com
 Phone: (847) 803 5000 • Fax: (847) 298-3101
 For Technical Assistance 800 / TEC-TRUE (800-832-8783)

GEBERIT Manufacturing, Inc.
 1100 Boone Drive, Michigan City, IN 46360
 www.us.geberit.com
 Phone: (219) 879 4466 • Fax: (219) 872-8003
 For Technical Assistance 800 / 225-7217

D23924-003&BDC © 08-2009

