

THIS SPACE FOR DESIGNER/ ENGINEER APPROVAL

Job/Customer _____ Date _____ Contractor _____

Model Specified _____ Qty _____ Approved By _____

Designer/Engineer _____ Date _____ Contractor's PO# _____

Submitted by _____ Date _____ Other _____

2153 Series FORGED BRASS GAS BALL VALVES W/ T-HANDLE IPS 1/2 TO 175 WOG - ISO 9001:2000

ITEM #	SIZE	P/CARTON	P/CASE	A	B	C	D
21532	1/2"	12	144	1/2	2 1/4	1 3/8	1
21533	3/4"	12	96	3/4	2 3/8	1 11/16	1
21534	1"	6	60	1	2 7/8	1 3/4	1



NO.	DESCRIPTION	MATERIAL
1	BODY	BRASS
2	END CAP	BRASS
3	SEATS	PTFE
4	BALL	BRASS HCP
5	STEM	BRASS
6	O-RING	FKM
7	PACKING GLAND	BRASS
8	HANDLE	ALUMINUM
9	SCREW	BRASS

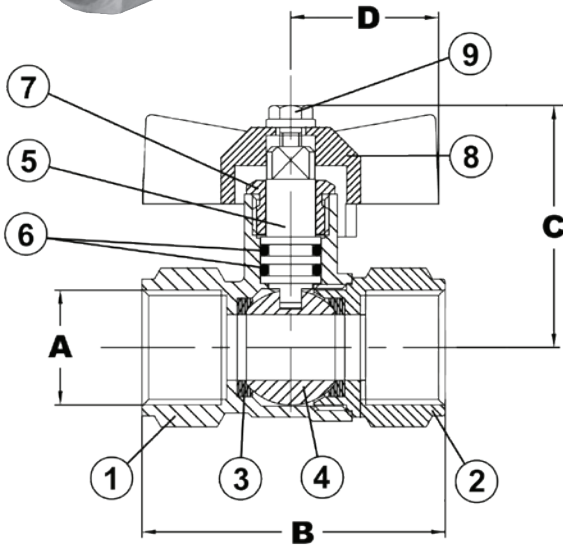

TEMP °F	WOG
100	175
150	175
200	175
250	175
300	175
350	175
366	175

Specifications: Designed for use with natural, manufactured, mixed liquefied petroleum and LP gas/air mixtures. This approved Webstone valves is actuated by a blowout proof stem. Handle is available in multiple configurations to satisfy local code regulations. This valve's design is UL listed, and CSA certified to meet both Canadian and US standards for use with petroleum and natural gas mixtures. This valve complies with ANSI 2.21.15 for use as a gas appliance connector valve for a 1/2 lb system. Threaded ends comply with ANSI B1.20.1

Webstone Company, Inc.
www.webstonevalves.com

Quality and Commitment Since 1954

Tel: (800) 225-9529 • Fax (800) 336-5133

Webstone product specifications in U.S. customary units are approximate and are provided for reference only. Webstone reserves the right to change or modify product design, construction, specifications or materials without prior notice and without incurring any obligation to make such changes and modifications on Webstone products previously or subsequently sold.

2153spec_060909