



**SUBMITTAL SHEET**  
**MODEL 2600TC • 1/2 H.P.**  
**BATCHFEED DISPOSER**

- Batch feed operation...No wall switch!
- High-speed 2600 r.p.m. permanent magnet motor produces more power per pound.
- Stainless steel, rust free grinding components.
- Fast and easy mount system provides a no hassle installation.
- Power cord included.
- Sound insulated for quiet operation.
- Safe for properly sized septic tanks.
- Longest warranties in the industry demonstrates commitment to quality.



**Five Year In-Home Service**  
 (see below)



**DIMENSIONS**

Knock-out for dishwasher drain connector sized for 7/8" I.D. rubber hose.

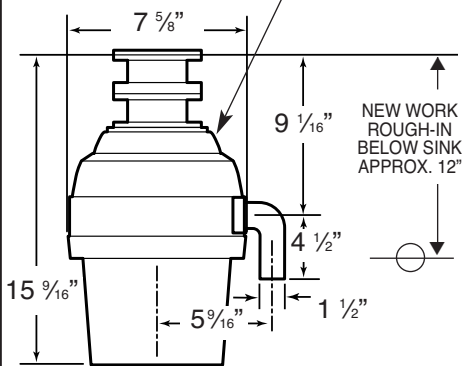

Measurements are in inches

**SPECIFICATIONS**

Motor Horsepower	1/2 H.P.
Motor Speed R.P.M.	2600
Voltage	115
Hz	60
Current-Amps	4.5
Motor Type	Permanent Magnet
Sink Flange	Stainless Steel & Celcon
Stopper/Actuator	3 Position
Splash Guard	Removable
Waste Elbow	ABS
Feed	Batch Loading
Grind Ring	Stainless Steel
Swivel Impellers	Stainless Steel
Turntable	Stainless Steel
Hopper	Glass Filled Nylon
Grinding Chamber	Corrosion Proof Glass Filled Polyester
Bearings	Permanently Lubricated; Sleeve Type
Overload Protector	Manual Reset Type
Sound Shell	Yes
Shipping Weight (lbs.)	11.22
Pallet Quantity	75

**Waste King® Warranty**

Any Waste King Legend® Model 2600TC less than 5 years old that develops a material or mechanical defect will be replaced, in your home free of charge .

Due to continued product improvement, system configurations and specifications may change without notice.



4240 E. La Palma Avenue  
 Anaheim, California 92807  
 (800) 854-3229