



# SUBMITTAL SHEET

9980TC\* • 1 H.P.

**BATCH FEED OPERATION**

**PROFESSIONAL 3-BOLT MOUNT SYSTEM**

- Batchfeed operation...No wall switch required!
- High-speed 2800 r.p.m. permanent magnet motor produces more power per pound.
- Stainless steel, rust free grinding components.
- Longest warranties in the industry demonstrates commitment to quality.
- Sound insulated for quiet operation.
- **Safe for properly sized septic tanks.**

**SEPTIC SAFE**



**10 Year In-Home Service Warranty**  
(see below)



## DIMENSIONS

Knock-out for dishwasher drain connector sized for 7/8" I.D. rubber hose.

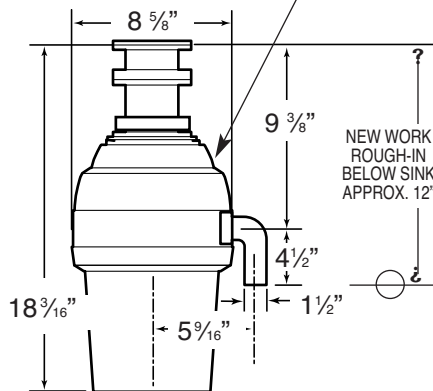

Measurements are in inches

## WARRANTY

Any Model 9980TC less than 10 years old that develops a material or mechanical defect will be replaced in your home free of charge.

## SPECIFICATIONS

Motor Horsepower	1 H.P.
Motor Speed R.P.M.	2800
Voltage	115
Hz	60
Current-Amps	6.0
Motor Type	Permanent Magnet
Sink Flange	Stainless Steel
Stopper/Actuator	3 Position
Waste Elbow	ABS
Feed	Batch Loading
Grind Ring	Stainless Steel
Swivel Impellers	Cast Stainless Steel
Turntable	Stainless Steel
Hopper	Glass Filled Nylon
Grinding Chamber	Corrosion Proof Glass Filled
Bearings	Polyester Permanently Lubricated; Sleeve Type
Overload Protector	Manual Reset Type
Sound Shell	Yes-Full
Shipping Weight (lbs.)	16.620
Pallet Quantity	75

\* 36" power cord is included.

Due to continued product improvement, specifications may change without notice.

## Anaheim Manufacturing

4240 E. La Palma Avenue • Anaheim, California 92807

(800) 854-3229

www.wasteking.com