

TOTO®

TS100AL Trilogy® Showerhead



TS100AL#CP - Trilogy® Showerhead

- Clean, elegant design and satisfying flow for TOTO shower suites
- Rubber nozzles provide easy cleaning to avoid calcium build up
- 1.75 gpm (6.6 lpm) maximum flow rate

■ **TS100AL#CP**
Trilogy® Showerhead,
polished chrome finish.

Finishes:

Standard Polished Chrome

Other See price book for additional finishes

TS100AL Trilogy® Showerhead

■ DESIGN

Designed to match our line of residential bathroom products, TOTO's® shower and bath trim complete any bathroom suite.

■ SPECIFICATIONS

Flow Rate: 1.75 gpm (6.6 lpm) max.
 Warranty: Lifetime Limited Warranty (Residential use)
 One Year (Commercial use)
 Shipping Weight: 8.0 lbs.

Shipping Dimensions: 13-3/4"L x 8-1/2"W
 x 5-1/2"H

■ CODES/STANDARDS

Complies with and exceeds the following standards:
 ASME A112.18.1 / CSA B125.1

Listed by:

IAPMO / cUPC and other municipalities

These dimensions and specifications are subject to change without notice.

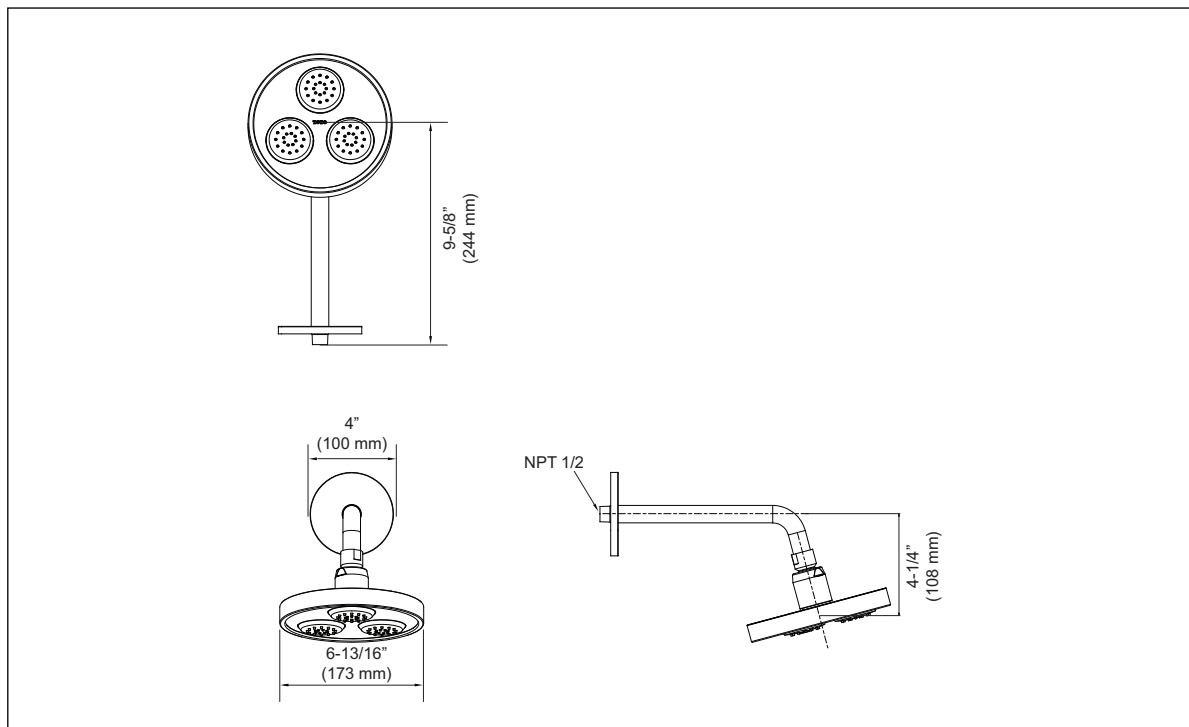
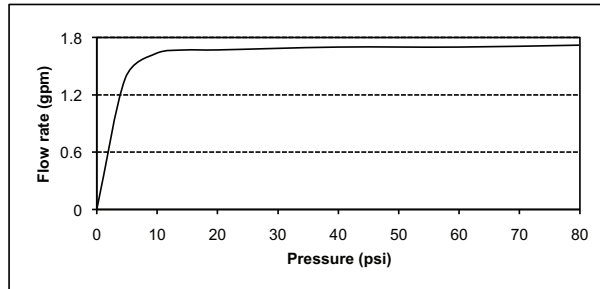

TS100AL - Trilogy® Showerhead

TOTO®

TOTO® U.S.A., INC. • 1155 Southern Road, Morrow, GA 30260
 Tel. (888) 295-8134 • Fax. (800) 699-4889 • www.totousa.com

Printed in U.S.A. © TOTO® LTD. 08/08 #C30600

Printed on recycled paper ♻️

REV 05/09