

SPEAKMAN ANYSTREAM® VINTAGE

Showerhead S-3019

SPECIFICATION

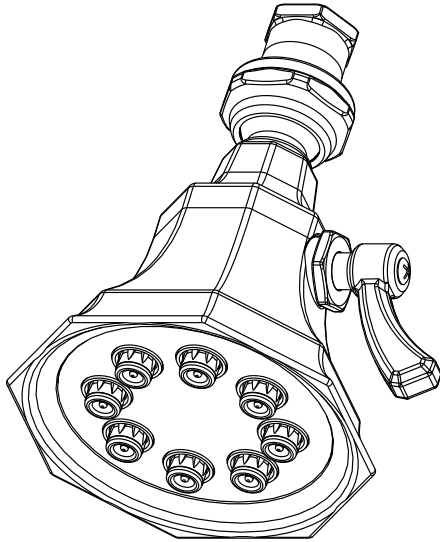

FEATURES:

- Octagonal 1920s Speakman showerhead inspired design
- 8 jets with 64 spray channels
- Solid brass construction
- Spray adjusting handle
- 2.5 gpm (9.5 L/min) flow rate

COMPLIANCE:

- Meets ASME A112.18.1/CSA B125.1

AVAILABLE FINISHES:

ADD SUFFIX TO MODEL #

- Polished Chrome (standard)

WARRANTY:

- 1 year limited

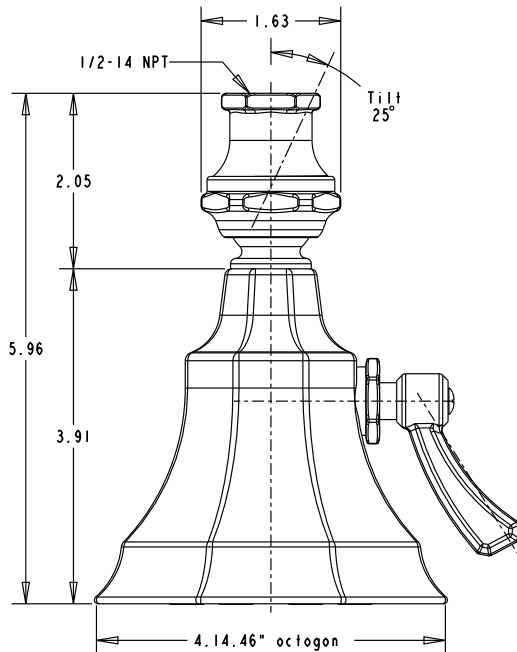

NOTE: 1. All dimensions are in inches (millimeters) unless otherwise specified and are subject to change without notice.

THIS SPACE FOR ARCHITECT/ENGINEER APPROVAL.

SPEAKMAN®

400 ANCHOR MILL ROAD | NEW CASTLE, DE 19720
 P: 800-537-2107 | F: 800-977-2747
 WWW.SPEAKMANCOMPANY.COM



REVISION DATE: APR. 2012