



Incandescent

**Directional**

**Directionals**

Catalog No.	Finish			Lamping	Dimensions (Inches)		
	Brushed Nickel	White	Urban Bronze		A	B	C
P6160	-09	-30	-174	3 PAR-20 50w	27	6-5/8	4-3/4

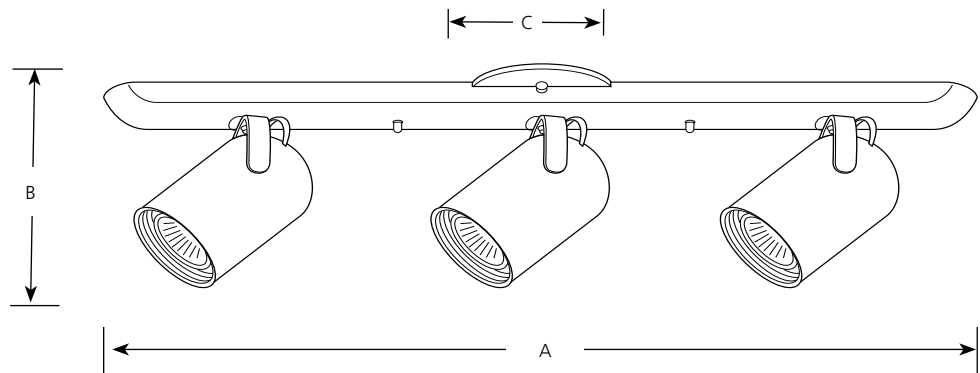

**Specifications:**

General

- Plated Brushed Nickel (-09) finish
- Painted White (-30) or Urban Bronze (-174) finishes
- Steel construction
- Three heads mounted on a bar
- 180 degree vertical and 360 degree horizontal adjustment
- Matching single lamp units available.
- Solid round back style

Mounting

- Wall or ceiling mount
- Canopy covers a standard 4" hexagonal recessed outlet box
- Mounting strap for outlet box included

Electrical

- Medium base ceramic sockets
- Pre-wired

Labeling

- cCSAus Damp location listed

Progress Lighting  
 701 Millennium Blvd.  
 Greenville, South Carolina  
 29607

www.progresslighting.com

Rev. 02/14