

Type _____
 -10 -13
 P3574

Catalog No.	Finish		Lamping	Socket	Dimensions (Inches)		
	Polished Brass	Brushed Steel			A	B	C
P3574	-10	-13	3-13w Twin CF	GX23	19-3/8	17	54

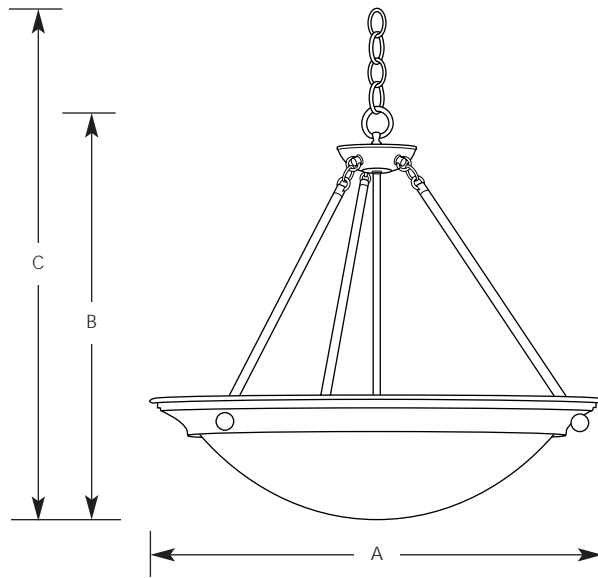

Specifications:

General

- Steel construction with Polished Brass (-10) or Brushed Steel (-13) finish
- Satin white glass
- 3 feet of 9 gauge chain
- Companion wall sconce, semi-flush and flush mount ceiling fixture

Electrical

- 15 feet of wire
- 120V, HPF ballasts
- Pre-wired

Labeling

- UL-CUL listed

Mounting

- Chain-hung ceiling
- Covers outlet box
- Mounting strap for outlet box included
- Canopy 5-1/2" dia.

Type _____
 -10EB -13EB
 P3574

Catalog No.	Finish		Lamping	Socket	Dimensions (Inches)		
	Polished Brass	Brushed Steel			A	B	C
P3574	-10EB	-13EB	3-13w Quad CF (4 pin)	GX24q-1	19-3/8	17	54

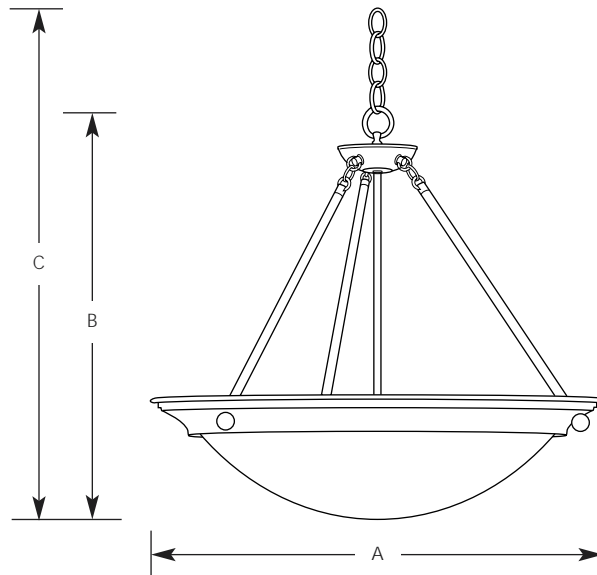

Specifications:

General

- Steel construction with Polished Brass (-10) or Brushed Steel (-13) finish
- Satin white glass
- 3 feet of 9 gauge chain
- Companion wall sconce, semi-flush and flush mount ceiling fixture

Electrical

- 15 feet of wire
- 120/277V HPF electronic ballast
- Pre-wired

Labeling

- UL-CUL listed

Mounting

- Chain-hung ceiling
- Covers outlet box
- Mounting strap for outlet box included
- Canopy 5-1/2" dia.

