



Linear Fluorescent

**Slim Line Wrap
Energy Star**

Modular Fluorescent

Type _____
-30STR
P7189

Catalog No.	Finish White	Lamping	Dimensions (Inches)		
			A	B	C
P7189	-30STR	2- F32T8	50-5/8	6-1/4	2-1/2

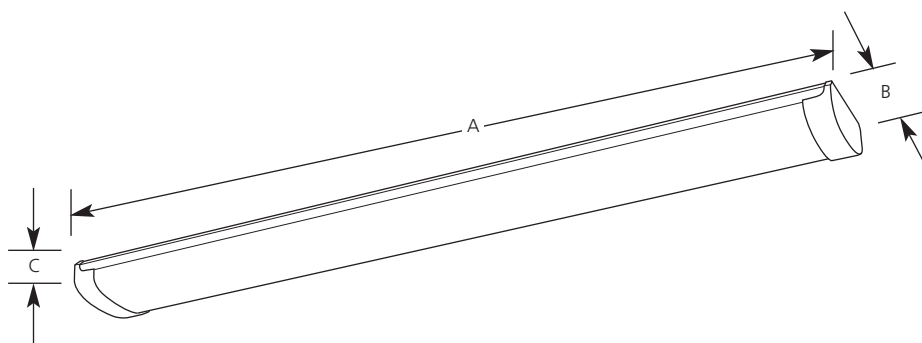

Specifications:

General

- Extruded frosted acrylic lens: 47-5/8" L x 6.3" W x 1.81" ht.
- Lens snaps in place
- Very shallow profile (2-1/2")
- White plastic ends
- White steel chassis
- Removable cover for in line wiring
- Sockets metal backed
- Utilizes T8 lamps for electronic ballast
- Energy Star compliant

Mounting

- Ceiling mounted, individual or continuous run
- Covers any outlet box

Electrical

- 120v NPF electronic ballast
- Bi-pin twist in lampholders

Labeling

- UL-CUL damp location listing
- Energy Star compliant



Progress Lighting
701 Millennium Blvd.
Greenville, South Carolina
29607

www.progresslighting.com

Rev. 7/09