

Type _____

-09

P3421

P3422

Catalog No.	Finish	Lamping	Dimensions (Inches)		
	Forged Bronze		A	B	C
P3421	-09	3 (m) 75w	16-3/4	26-1/4	98
P3422	-09	4 (m) 100w	22-3/4	31-1/4	103

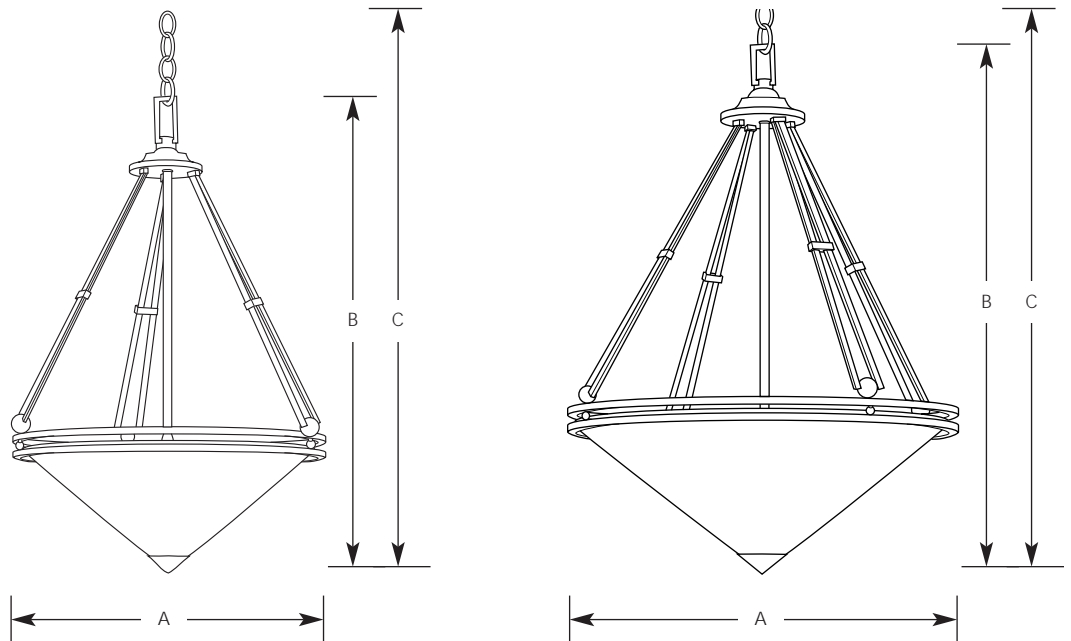

Specifications:

General

- Etched white opal glass conical bowls
- Double rod suspension of bowls mounted in double rings
- P3421 has 6 feet of 9 gauge matching chain, and P3422 has 10 feet of 9 gauge chain
- Steel construction
- Plated brushed nickel finish
- Companion wall bracket, chandeliers, mini-pendant, and close to ceiling units

Mounting

- Ceiling chain mounted
- Canopy covers a standard recessed 4" octagonal outlet box
- Mounting strap for outlet box included

Electrical

- Ceramic medium based sockets
- 15 feet of wire
- Pre-wired

Labeling

- UL-CUL listed