

Type _____
 -09 -30
 P2525

Catalog No.	Finish		Dimensions (Inches)	
	Brushed Nickel	White	A	B
P2525	-09	-30	52	8-1/8
<u>Blades</u>				
Side 1	Cherry	White		
Side 2	Natural Cherry	White		

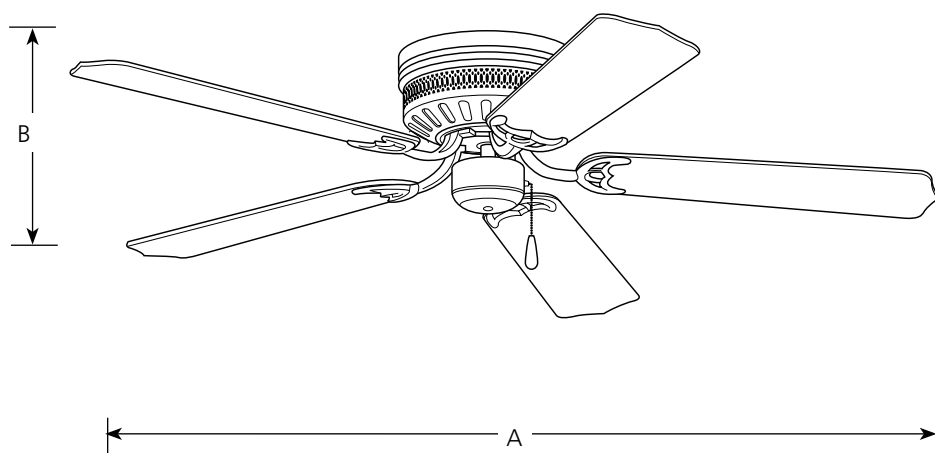

Specifications:

General

- 15 year limited warranty
- Hugger style housing

Blades

- Five blades
- 11 degree pitch
- MDF blade material

Motor

- Triple capacitor speed control; manual reverse control
- 153mm dia x 13mm high

Mounting

- Flush ceiling mounted
- Unit covers standard recessed 4" octagonal outlet box. Note: An outlet box assembly designed for fan installation is required (not included)
- Mounting hardware is included

Electrical

- Prewired
- 1/8" IP accessory adapter

Labeling

- UL listed