

NOTES:

- 1. PART NO. HAS SUFFIX "B" OR "W" (BLACK OR WHITE).
- 2. BAG 5-007 IN A SEPARATE BAG.
- 3. APPLY SUPER LUBE GREASE OR EQUIVALENT.
- 4. APPLY LOCTITE 680 OR EQUIVALENT.
- 5. ASSEMBLY HEIGHT OF ITEM SHALL BE DETERMINED BY WATER TEST. HANDLE SHALL HAVE SLIGHT PLAY (MOVEMENT UP AND DOWN).
- 6. WATER TEST WHOLE UNIT.
- 7. AFTER ASSEMBLY, THE DISTANCE BETWEEN THE TOP SURFACE OF ITEM 7 AND THE TOP SURFACE OF ITEM 6 MUST BE BETWEEN .056 -.070

**8 USE 45 IN.LBS TO INSTALL ITEM # 10 ONTO ITEM # 2**

BILL OF MATERIAL (CURRENT LEVEL)

ITEM	PT/ASSY	DESCRIPTION	TYPE	QTY.
1	50874	BODY COVER	PART	1
2	50875	PLASTIC INSERT	PART	1
3	50058	SPOUT	PART	1
4	91099	O-RING #2-009	PART	2
5	50061	SPOUT TIP	PART	1
6	5-003	VALVE STEM ASM	ASSEMBLY	1
7	50074	T-BAR	PART	1
8	50071	COMPRESSION SPRING	PART	1
9	105-4B	RO AIR GAP	ASSEMBLY	1
10	50062	NIPPLE	PART	1
13	50064	LOCKING TOOTH WASHER	PART	1
14	50065	7/16-24 NUT	PART	1
15	5-007	1/4 COMP KIT	ASSEMBLY	1
16	50060	HANDLE	PART	1

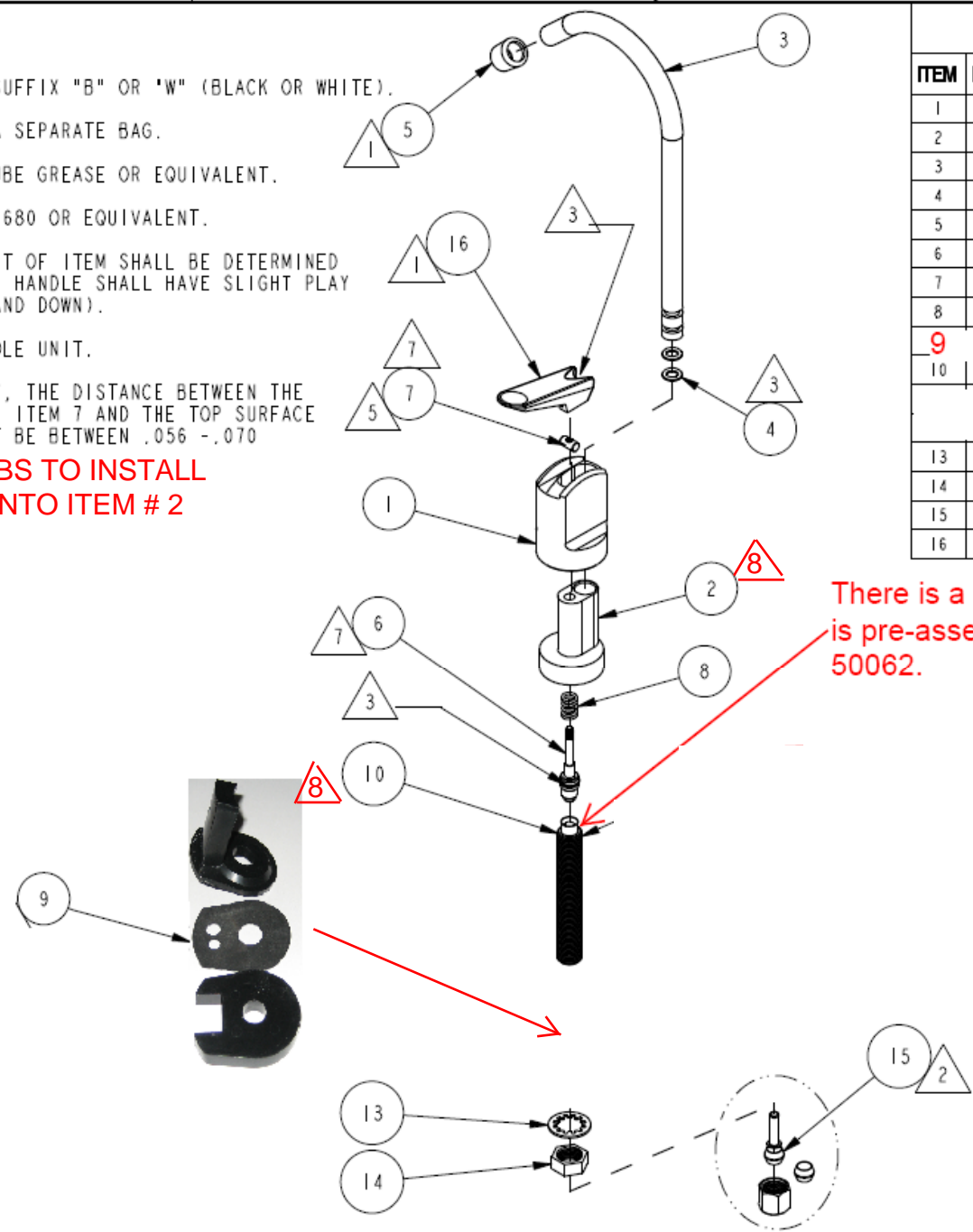

There is a o-ring here that is pre-assembled with the 50062.

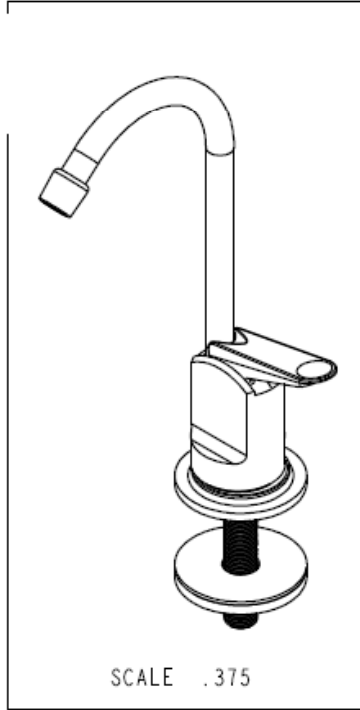

SPECIFICATION DWG

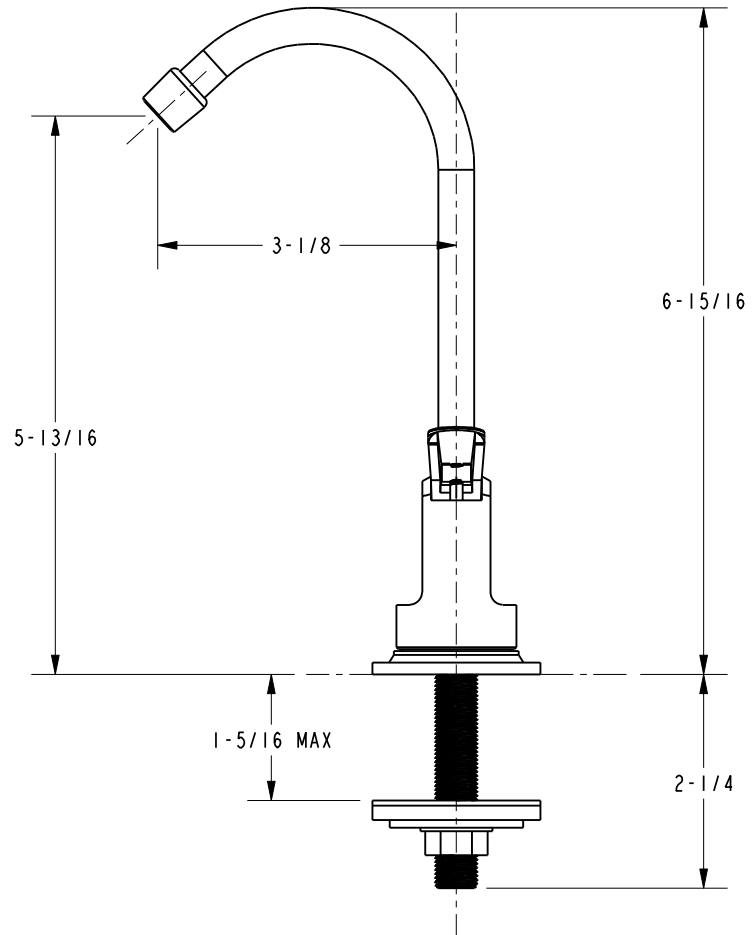
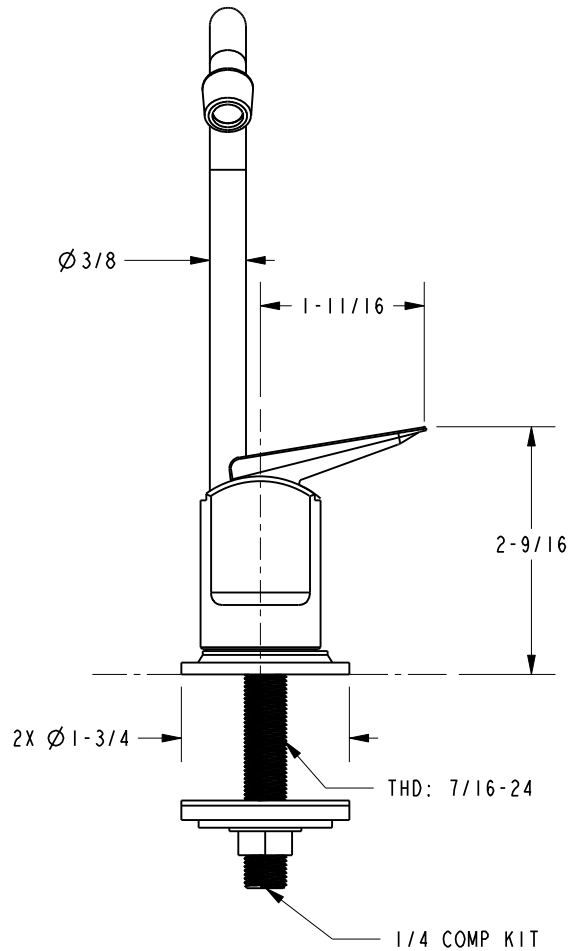

DIMENSIONS ARE IN INCHES AND AN APPROXIMATION OF A TYPICAL INSTALLATION

COPYRIGHT 2005 BRASSTECH, INC. THESE DRAWINGS AND THE DESIGNS DEPICTED HEREIN ARE THE PROPRIETARY PROPERTY OF BRASSTECH. ANY USE OR REPRODUCTION IS SUBJECT TO THE EXPRESS APPROVAL OF BRASSTECH. UNAUTHORIZED USE IS STRICTLY PROHIBITED. ALL RIGHTS RESERVED.

<b>BRASSTECH</b>		2001 E. CARNEGIE AVE. SANTA ANA, CA 92705 (949) 417-5207	
DWG NO.	<b>104B</b>	REV	C
SCALE	.500	REF.	-
		SHEET	2 OF 2