



FAUCET DESCRIPTION

- Chrome plated metal construction
- Pressure balancing cycle valve design
- 1/2" CC connections
- Supplied with vandal resistant screws

OPERATION

- Lever style handle with temperature indicators on the escutcheon
- Handle operates counterclockwise through a 270° arc with off at 6 o'clock, and maximum hot at the 9 o'clock position.
- Adjustable temperature limit stop to restrict the handle travel in the HOT direction
- Pressure balancing mechanism maintains selected discharge temperature to $\pm 2^\circ$

FLOW

- Vandal resistant shower head 2.5 gpm (9.6 L/min) maximum

CARTRIDGE

- 1222HD brass cartridge design
- Brass construction with stainless steel materials
- Accommodates back to back installations

STANDARDS

- Third party certified to ASME A112.18.1/CSA B125.1 and all applicable requirements referenced therein including ASSE 1016
- **ADA**  for lever handle

WARRANTY

- Warranted for 5 years against material or manufacturing defects

Single-Handle Pressure Balancing Shower Valve with HAF

Model: 8325



NOTE: 13/16" is the maximum finished wall thickness. Specify part number 96945 extension kit for finished walls up to 1-13/16" thick, or part number 96955 extension kit for finished walls up to 2-13/16"... as well as faucet model number

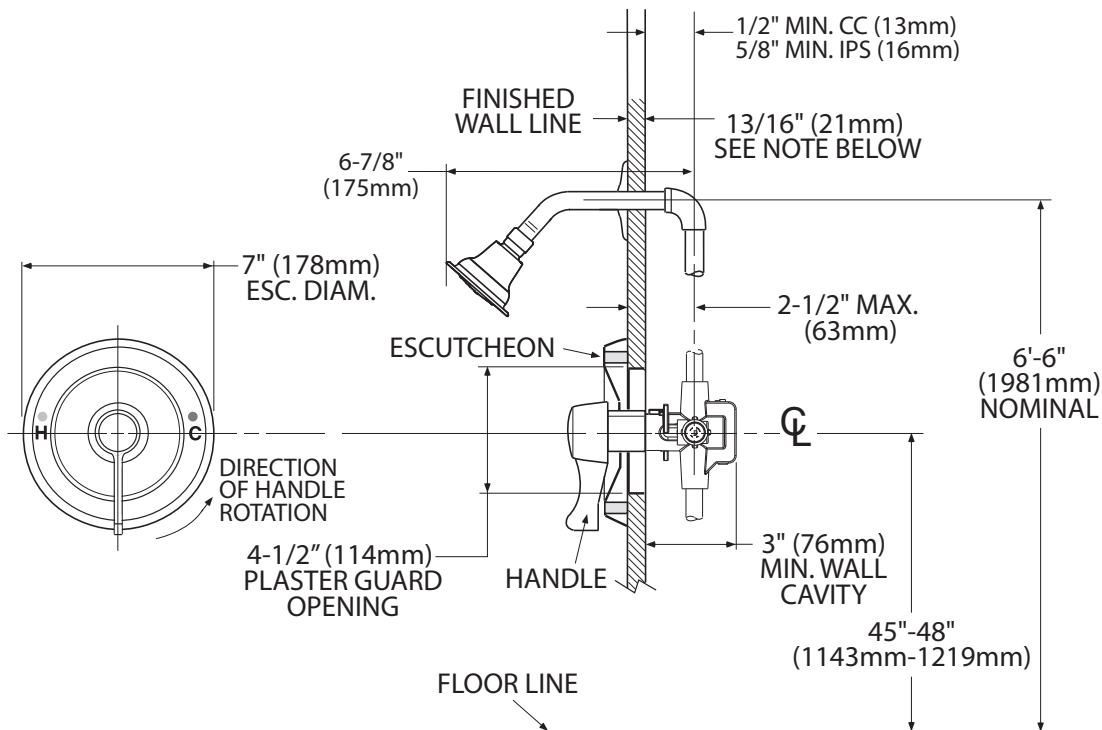

CRITICAL DIMENSIONS

(DO NOT SCALE)