

**KRAUS BRAND BATHROOM FAUCETS LIMITED LIFETIME WARRANTY**

KRAUS is proud to offer its customers the strongest, most durable ceramic cartridges in all solid brass Bathroom Faucets it manufactures. KRAUS guarantees all products to be free of defect in materials and craftsmanship. All KRAUS BRAND Bathroom Faucets carry a limited lifetime warranty from the original date of purchase.

If a product fails due to defect in material or craftsmanship during the warranty period, KRAUS will repair or replace the items at its sole discretion. Warranty does not apply when the item has been tampered with, misused, improperly installed, altered, or damaged due to abuse or accident. Proof of purchase (original sales receipt) must be provided to KRAUS for all warranty claims. Please contact one of our representatives if you need any additional details.

All KRAUS products must be installed by a licensed professional plumber or contractor to avoid any improper use or installation.

**IN NO EVENT SHALL KRAUS BE LIABLE FOR ANY INCIDENTAL, CONSEQUENTIAL OR SPECIAL DAMAGES, INSTALLATION COST, LABOR, TRAVEL TIME, FREIGHT COSTS INCURRED, LOST PROFITS, OR CONTINGENT LIABILITIES.**

KRAUS USA Inc. makes no representation that its products comply with any or all local building or plumbing codes. It is the consumer's responsibility to determine local code compliance.

This warranty extends to the original purchaser and first consumer.



## Exquisite Collection Installation Manual

Three-hole basin bathroom faucet

Dear Valued Customer,

Kraus would like to take this opportunity to thank you for purchasing Kraus products. It is our sincere hope that you are completely satisfied with your new purchase. We welcome any questions or comments you may have, and look forward to assisting you in the future.

Sincerely,  
Kraus customer service department.

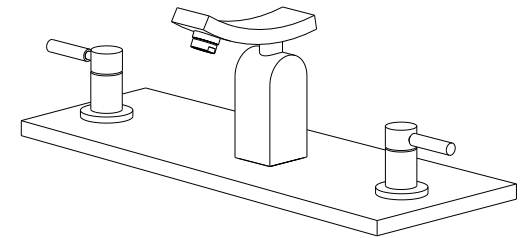

### Before Your Installation

Check to make sure you have the following parts indicated below:

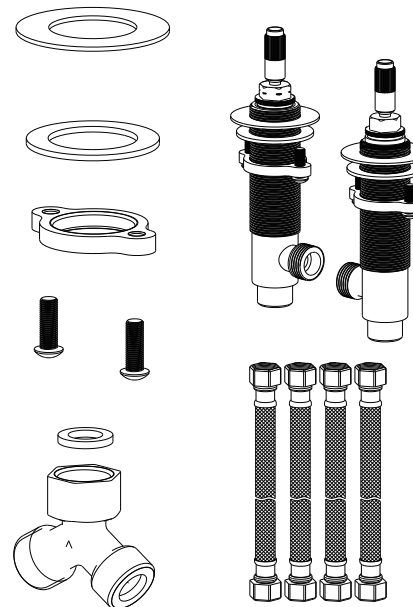

Model
<b>KEF-14303</b>

### Tools You Will Need

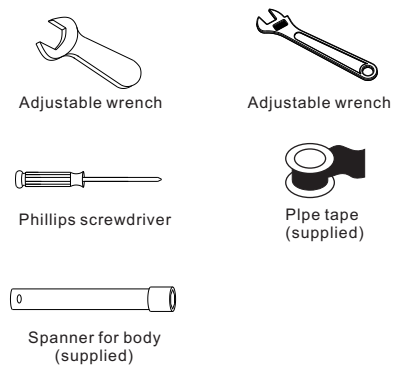

## Replacement Parts

Keep this manual for ordering replacement parts.

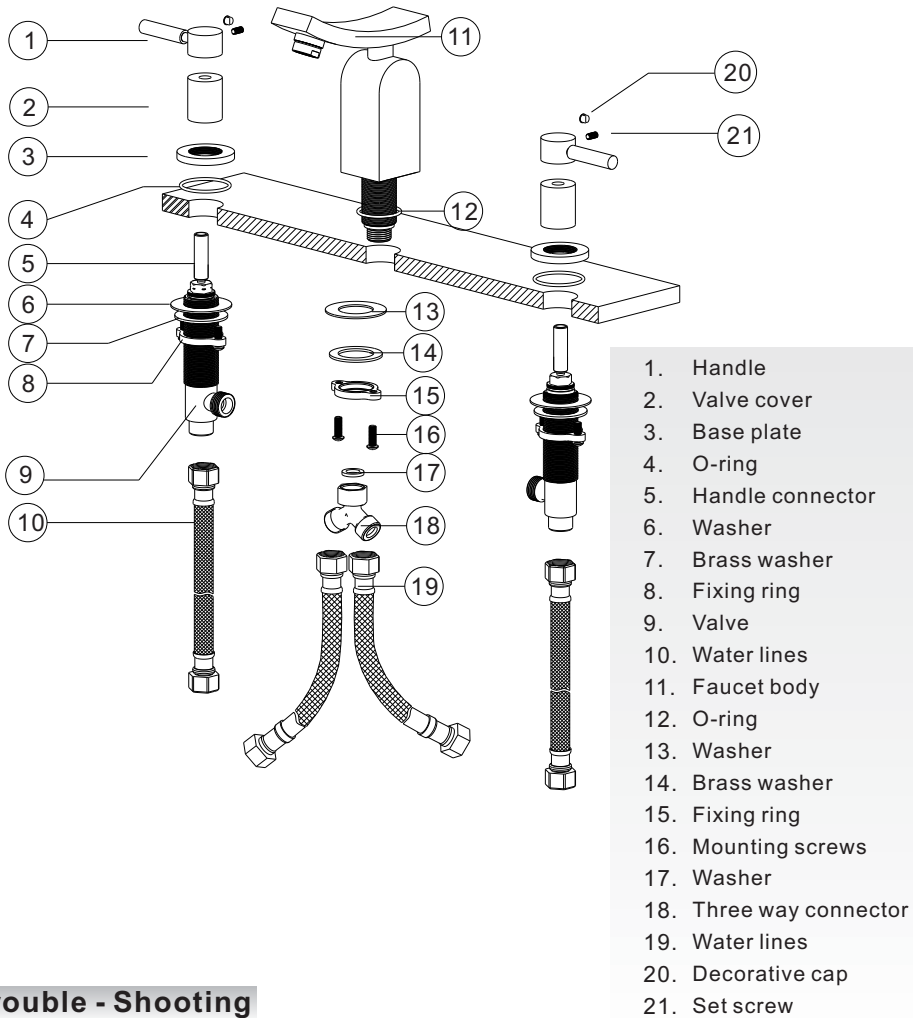

## Trouble - Shooting

PROBLEM	CAUSE	ACTION
Leaks underneath handle	Adjusting ring or cap has come loose.	Tighten the adjusting ring or cap.
Aerator leaks or has an inconsistent water flow pattern.	Aerator is dirty or misfitted.	Unscrew the aerator to check rubber packing or replace the aerator.
Water will not shut off completely.	Dirty or worn out plastic washer in the cartridge.	Remove handle and cartridge to check if ceramic disk is damage permanently or dirty. Re-install cartridge.

Contact Us Toll-Free at 1-800-775-0703; or visit our website at [www.kraususa.com](http://www.kraususa.com) ©2008-2011 Kraus USA Inc.

## Installation

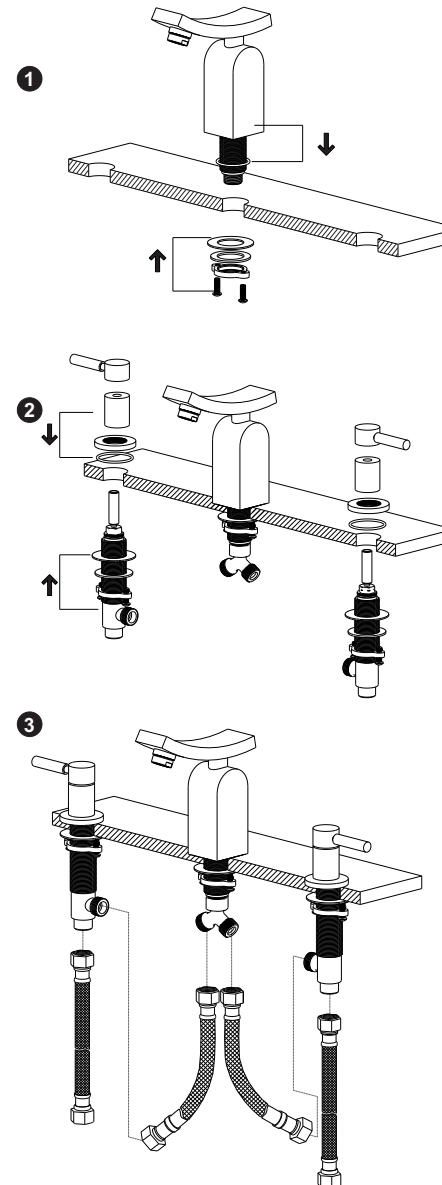

Fit O-ring 12 into the bottom groove of faucet body 11. Insert faucet body 11 into specified drill hole (1 1/4" - 1 1/2") on the counter top. Install washer 13 and brass washer 14 to the threaded tail pipe of the faucet body 11 from underneath the counter top and then screw the fixing ring 15 to securely tighten the faucet body. Fix faucet body 11 correctly and install the three way connector 18 by screwing onto the threaded tail pipe of the faucet body 11.

Install valve 9 into specified drill hole underneath the counter top. Place o-ring 4 into the base plate 3. Screw base plate 3 and the valve cover 2 into valve 9. Adjust the height and position of valve 9, then screw fixing ring 8 to tighten valve 9 underneath counter top securely. Install handle 1 to handle connector 5 of valve 9. Tighten set screw 21 with alley key and then place decorative cap 20 on handle 1.

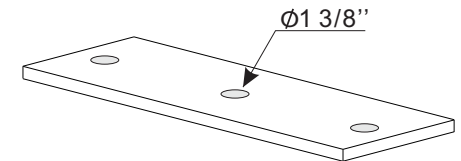

Screw waterlines 19 into three way connector 18 and valve 9. Connect waterlines 10 onto the bottom of valve 9 and then to main water supply line.

Contact Us Toll-Free at 1-800-775-0703; or visit our website at [www.kraususa.com](http://www.kraususa.com) ©2008-2011 Kraus USA Inc.