



www.healthcraftproducts.com

# SerenaSeat™

Installation Instructions: WS-18  
WS-26

## THANK YOU...

Thank you for purchasing the SerenaSeat™. We are confident that you will find the unique design and durable construction of this product to be of great assistance in your daily routine.

To fully enjoy your SerenaSeat™, please take a few moments to read these instructions. You should store these instructions in a safe place for future reference.

## SAFETY CONSIDERATIONS

**CAUTION:** It is your responsibility to see that your SerenaSeat™ is properly assembled, installed, and cared for. Failure to follow instructions in this manual could result in serious injury. Some surfaces can be slippery when wet - use this product with caution.

## SERENASEAT™ INSTALLATION / MAINTENANCE

The SerenaSeat™ should only be installed in areas where the mounting surface is structurally sound. Strengthening modifications may be required (see page 3 for details). Should not be installed in fiberglass / acrylic shower enclosures with insufficient stiffness and strength. Should not be installed into metal studs. If you are not equipped to undertake the outlined work we recommend that you have your SerenaSeat™ installed by a qualified contractor. Seat should only be used for sitting upon - not to be used for other purposes. Do not install seat in locations where seated user and seat are close to direct steam or hot water emissions. Suggested maximum user weight 450lbs/205kg, however this rating is conditional upon suitable fasteners and supporting surface. One person maximum capacity. **WOOD CONTACT SENSITIVITY** - some people may experience a skin rash or other reaction due to contact with certain types of wood. If unsure, test first.

## WOOD PANEL WARNING

In order to retain the natural beauty of the Brazilian Walnut (IPE), each slat is finished with an extremely durable 2-part oil finish that does not contain volatile organic compounds (VOCs) or other harmful chemicals.

A light brown or red discoloration may be noticed in water exposed to the wood, and is due to an excess of pigments (natural oils) in the wood reacting with minerals present in certain types of water (well water, hard water, etc.). This discoloration is a natural reaction often referred to as leaching and should fade over time. The applied oil finish also reduces the effects of leaching. If unsure, test wood in local water prior to installation.

## WARRANTY

All HealthCraft™ Products are covered by a one year limited warranty with the exception of hand grips which are subject to normal wear. Buyer hereby indemnifies, agrees to hold harmless and defend HealthCraft™ Products Inc. from and against any and all liabilities, claims, (founded and unfounded), losses, damages, costs and expenses (including without limitation consequential damages and reasonable professional fees) resulting from buyers specification, application, or improper use of goods described hereon; buyers omission or neglect.

HealthCraft™ Products Inc. does not assume any liability for damage resulting from services performed by others or faulty installation, misuse or misapplication of goods sold by HealthCraft™ Products Inc.

HealthCraft™ Products Inc. shall not be liable for prospective profits or special, indirect, or consequential damages, or for the cost of any corrective work done without HealthCraft™ Products Inc. prior approval. HealthCraft™ Products Inc. total liability hereunder shall in no event exceed the purchase price of the goods specified hereon.

## TOOLS REQUIRED

- Level
- Hammer
- Stud Finder
- Personal Protective Eyewear
- Carbide tip drill suitable for tile
- Protective blanket
- Center Punch

## CLEANING AND MAINTENANCE

The back panels of the SerenaSeat™ are removable to allow for cleaning of the wall behind the seat. Clean seat with water, and then wipe dry using a soft cloth. Do not use abrasive cleaning products.

## TIPS FOR DRILLING INTO TILE

- Use carbide tipped masonry drill on ceramic, or consider a diamond tip drill for porcelain tile.
- If possible, drill a smaller pilot hole first.
- Be careful to prevent the drill from moving when you first start it rotating - use duct tape or a wood guide on the surface of the tile to hold the drill from walking sideways.
- A variable speed drill on slow is best to start the hole. Do not apply too much pressure when drilling. Do not use a hammer drill.

## MOUNTING LOCATION

We strongly recommend that you give some thought as to the optimal location of your SerenaSeat™ before installation. The following suggestions are offered for your consideration, however, it is recommended to consider advice from the appropriate healthcare professional for locating of any support product. Also, consider the following when determining the optimal mounting location:

1. Move mounting location to match structure behind the wall.
2. Avoid electrical / plumbing behind the wall.
3. Where possible, drill through tile - not through grout.

The holes on the SerenaSeat™ were designed to contact wood studs spaced at 16" centers. If the position of the wood studs places the seat in an undesirable location, we recommend strengthening modifications to be done (see Page 3 for recommendations). When determining the seat height, consider the height of the user and their capabilities (**NOTE:** ADA guideline specifies seat height of 17-19" above the finished floor).

## RECOMMENDED INSTALLATION LOCATIONS:

- BACK WALL (a)** - If side wall is less than 36", seat should be mounted on back wall.
- SIDE WALL (b)** - If side wall is greater than 36", seat can be mounted on side wall (to reduce reaching for shower controls located on FAUCET WALL).

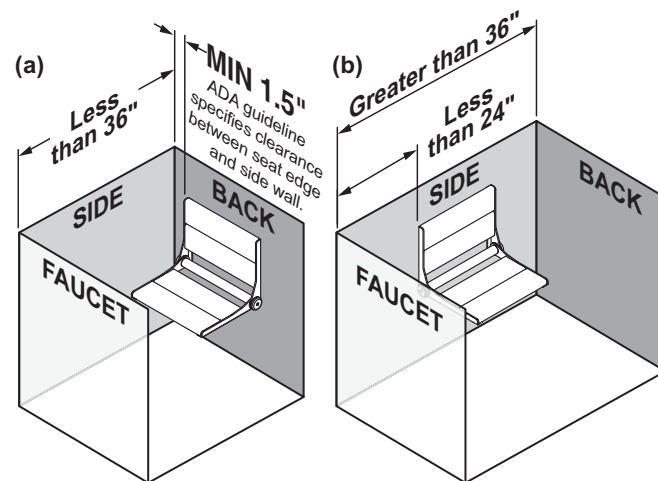

## INSTALLATION INSTRUCTIONS

Place a blanket down in the area that you will be installing the SerenaSeat™ to protect the shower or bathtub surfaces from parts that may fall during installation.

**A1.** Identify the horizontal and vertical location of the SerenaSeat™. Specifically, identify the location of the top hole on one side of the wall bracket as shown in of **Figure 1 (a)**.

**A2.** Notch the tile accurately with a center punch as shown in **Figure 2**. **NOTE:** A light tap is all that is required for punch to make notch.

**A3.** Drill hole for appropriate fastener as shown in **Figure 3**. Clear away debris from hole that could interfere with the seat sitting flush with the wall.

**A4.** Secure wall bracket using appropriate fasteners. Ensure the screw goes in as straight as possible so the flat head of the screw is within the countersunk area as shown in **Figure 4**. If it protrudes out, it may interfere with the sliding removal of the backrest panels.

**A5.** Once attached, use level as shown in **Figure 1 (b)** to ensure seat is straight. Identify the location of the top hole on the opposite wall bracket. **IMPORTANT:** Ensure distance between the wall brackets allows for easy sliding of the back rest panels (do not cause brackets to bend inwards).

Repeat steps A2 thru A4 first for the top hole on the opposite wall bracket and ensure it is level. Repeat steps A2 thru A4 the remaining holes.

**NOTE:** Perform a final tighten and inspection of all fasteners. Test the installation by pushing down / sitting on the seat.

**A6.** Once all screws are installed, the backrest panels can be slid onto the wall bracket as shown below. Ensure the orientation of each seat panel is correct (i.e. label on back of panel should face wall).

Your SerenaSeat™ is now installed.

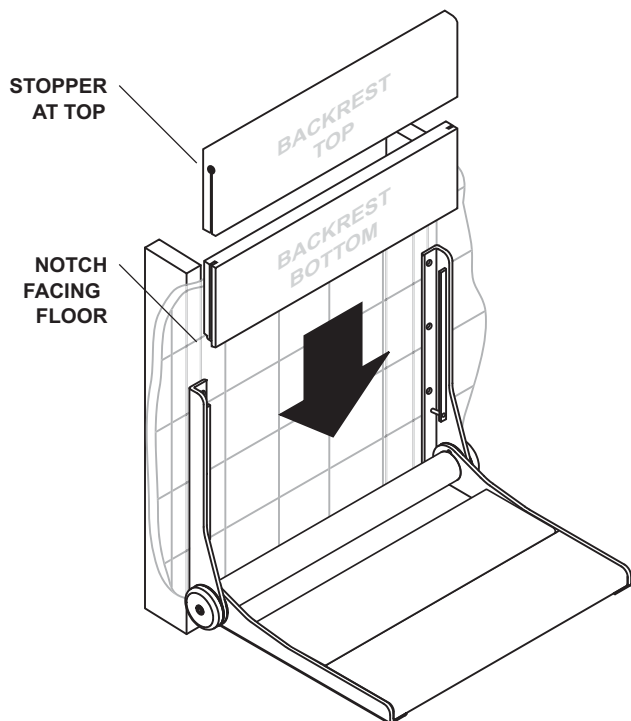

Figure 1.

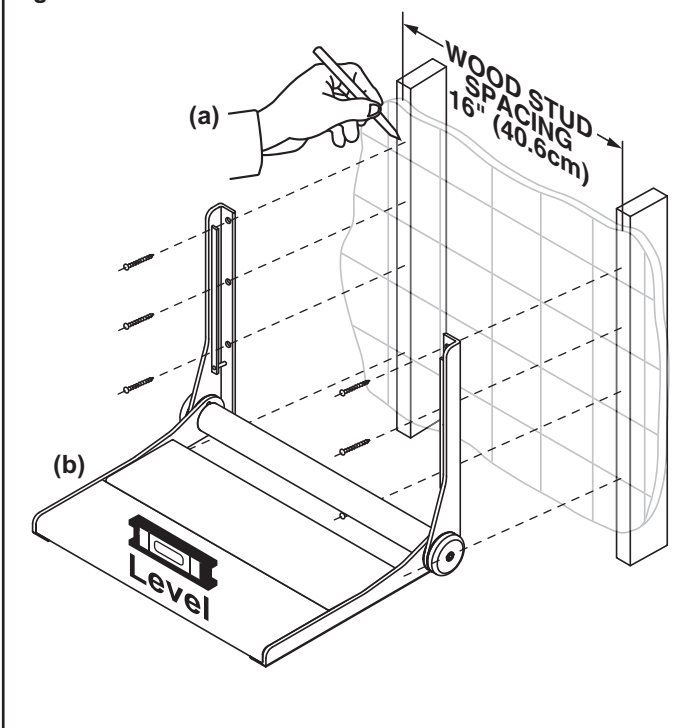

Figure 2.

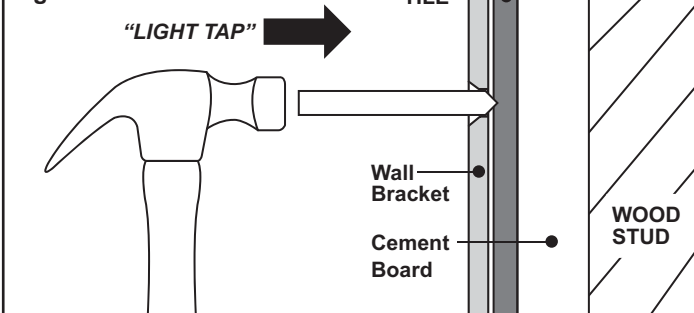

Figure 3.

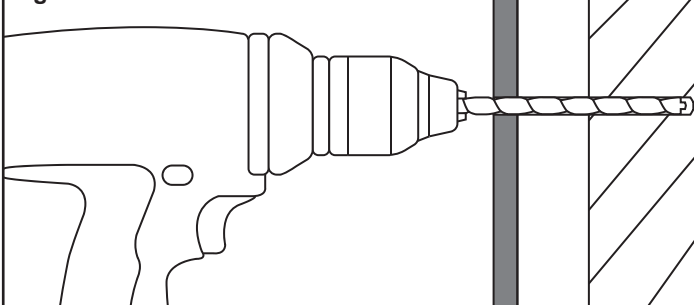
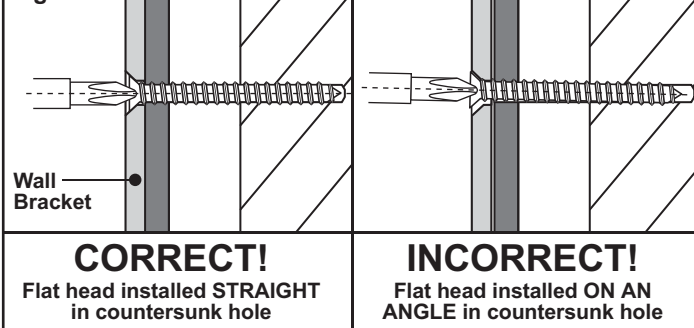

Figure 4.



## TIPS FOR LOCATING A WOOD STUD

- If the drywall is exposed, use a stud sensor to locate a stud.
- If there is tile on the wall, try a stud sensor to locate a stud. If no stud is found, measure 16" from a perpendicular wall. Drill a small hole in the grout to ensure the stud has been found. If there is no stud at this location, bend a piece of wire and insert it through the hole. Spin the wire to determine exactly where the stud is located and mark its location. Patch all holes with silicone to keep moisture out of the wall.
- If there is access to the backside of the bathroom wall (i.e. through a closet), measure the stud location and transfer the measurements into the bath area.

## STRUCTURAL REINFORCEMENT SUGGESTIONS

**NOTE:** Due to variances in local construction methods and materials used, details given below are suggestions only. Consult the appropriate local contractor for specific advice. For concrete walls, you may be able to install fasteners (such as a wedge anchor) directly into the concrete wall without modification.

If there is access to the backside of the bathroom wall (i.e. through a closet) and structural reinforcement is required, consider cutting a hole in this backside wall to allow access to the bathroom wall from behind (without having to remove / replace ceramic tiles).

1. Choose optimal mounting location of seat including height (\*H) and side to side location (L) as shown in **Figure 1**. **NOTE:** If accessing the bathroom wall from the backside, transfer the measurements for the support rail location to the backside wall as shown in **Figure 1b**. Mark the height and location on the wall for future reference.

**\*NOTE:** ADA guideline specifies seat height of 17-19" above the finished floor.

2. Find wall support studs & cut hole in wall board to expose wall studs as shown in **Figure 1**. Suggested hole size is height (A) of 18-24" (48-61cm) and width (B) corresponding to wall stud spacing. Expose half width of each stud to facilitate re-installation of wall board patch. **IMPORTANT: Avoid any utilities located in wall!**

3. Fabricate a support frame structure from suitable wood pieces as shown in **Figure 2**. Support frame width (D) should fit snugly within wall studs. Support frame height (E) should be from 24-32" (61-81cm) high or more, depending on material and stiffness of wall studs. Locate top cross member (F) to position in line with top hole on the wall bracket when seat is at install height (H). Lower cross member (G) should be spaced at C = 14.125" (37.465cm) center to center from top cross member (see Page 4 for dimensions of 2 center cross members). Use a generous quantity of wood screws and glue to hold the support frame structure together as shown. See alternative to support frame as shown in **Figure 3**.

4. Insert support frame structure through hole in wall and secure uprights to wall studs using a generous amount of wood screws.

5. Complete the SerenaSeat™ installation instructions on Page 2. Then, patch the wall cutout (if backside access to bathroom, consider making an access panel for future servicing) to match the surrounding wall as shown in **Figure 4**.

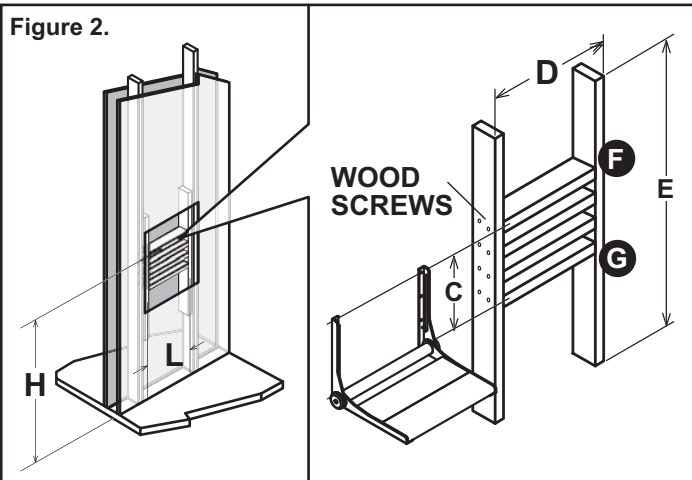
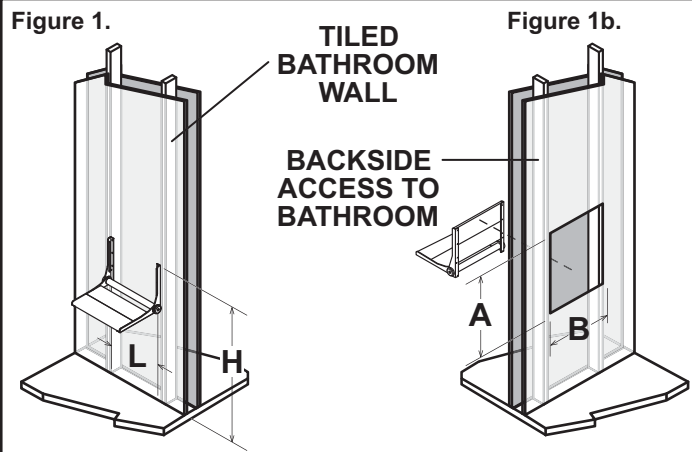

## FIGURE 3: ALTERNATIVE TO SUPPORT FRAME - MULTI-LAYER PLYWOOD INSIDE WALL WITH WALLBOARD PATCH (TOP VIEW)

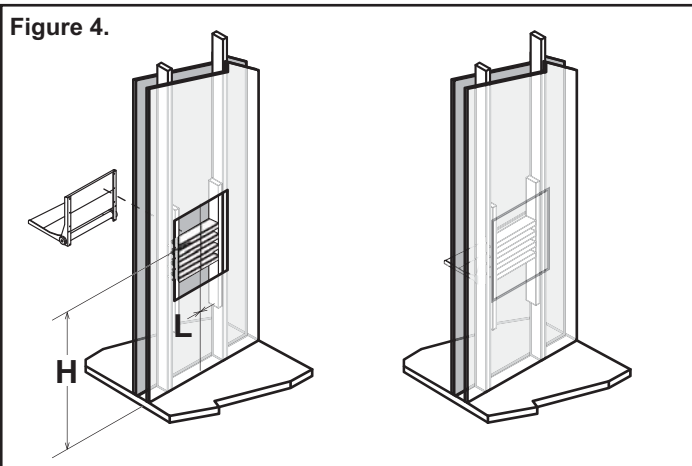
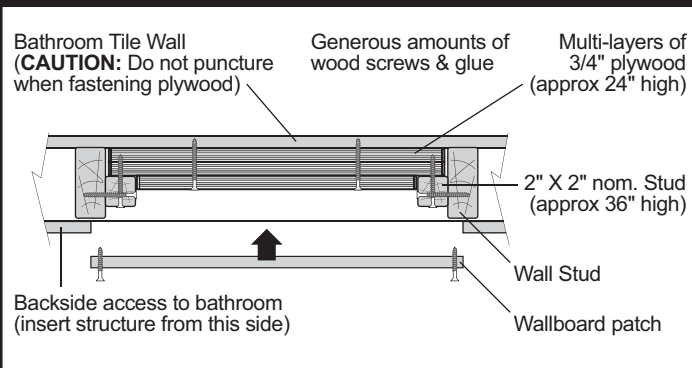

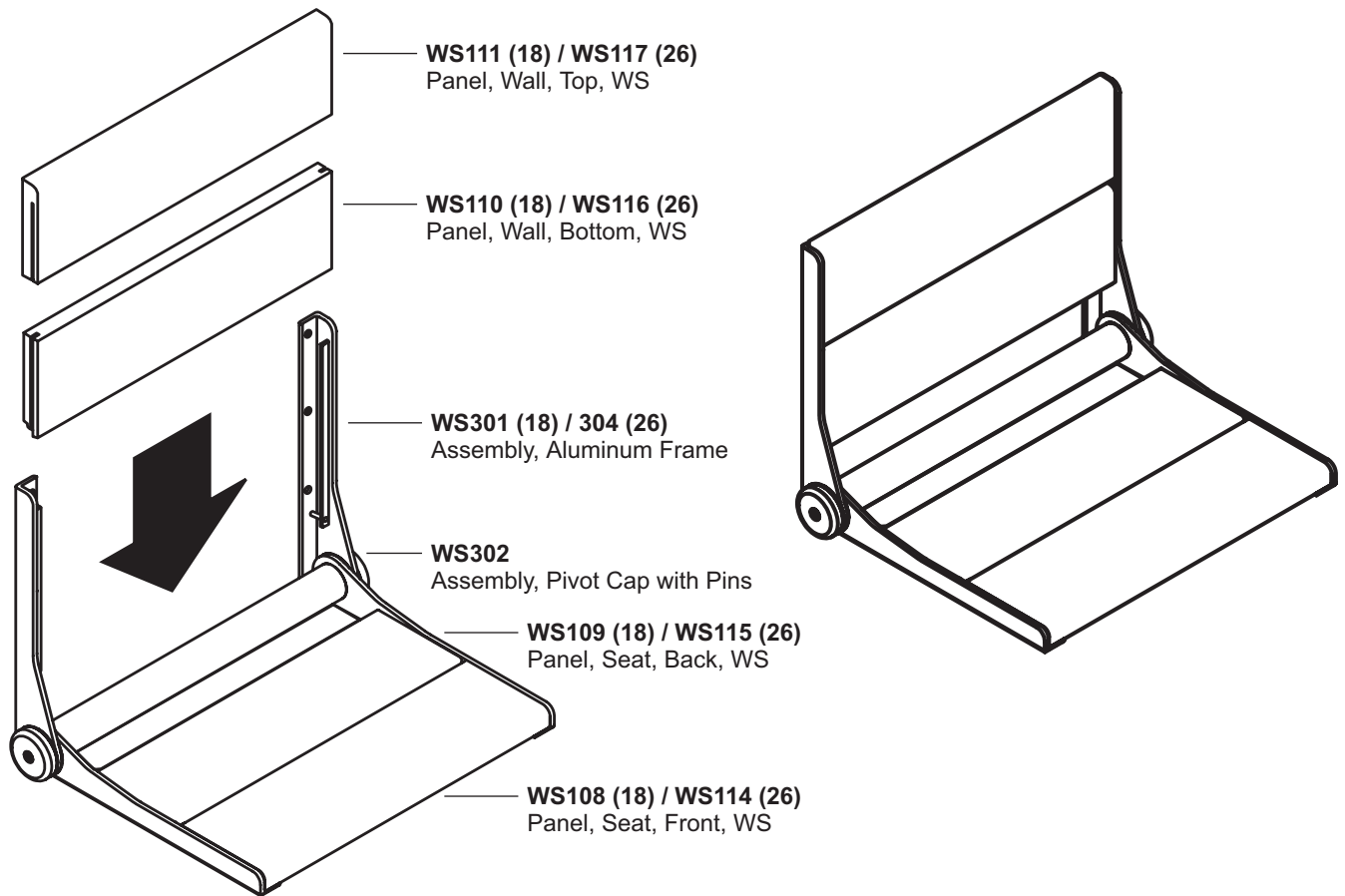

**DIMENSIONAL DIAGRAM**

**BACK VIEW**

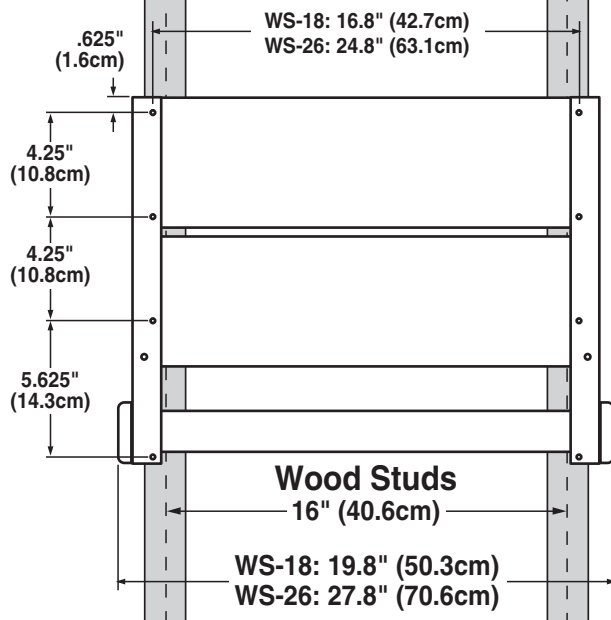

**SIDE VIEW**

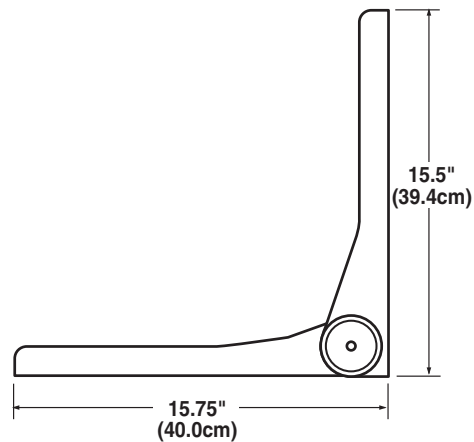

**SIDE VIEW (FOLDED)**

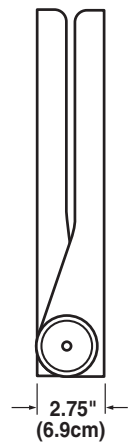

**HARDWARE**

**HW176**  
 Screw, FPH WS, #10 x 3", S/S



**x8**