

Installation Instructions / Warranty

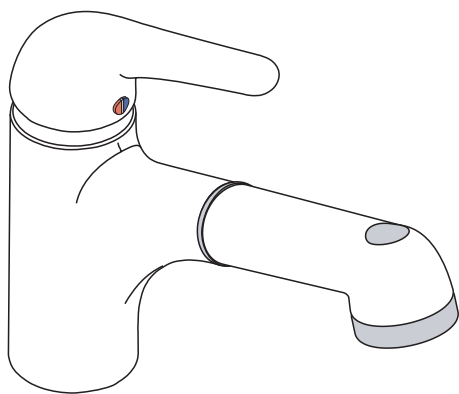

Axor Steel
35807801

hansgrohe

Axor Steel Kitchen Faucet 35807801

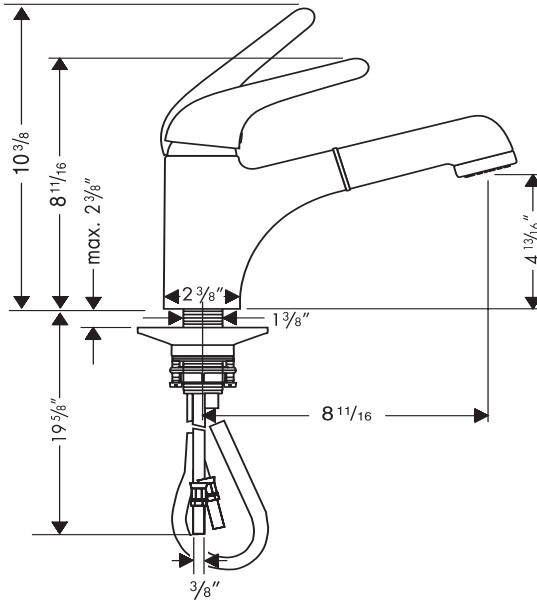

Max water pressure	145 PSI
Recommended water pressure	45 - 72.5 PSI
Recommended hot water temp	120° - 140° F*
Hole size in mounting surface	1 1/2"
Max. mounting surface thickness	2 1/4"
Flow rate:	2.2 GPM

*Please know and follow all applicable local codes when setting the temperature on the water heater. In Massachusetts, the water heater may be set no higher than 112°F.

Installer Notes:

Significant pressure differences between the hot and cold water supplies should be corrected.

The supply hoses on this faucet require 3/8" compression fittings (not included).

Backflow prevention is provided by check valve in the sprayhead.

Preparation for Installation:

Turn the water supplies off before removing the old faucet.

Flush the supply lines of debris before beginning installation. Damage to the cartridge caused by debris is not covered under the Hansgrohe limited lifetime warranty.

Install the faucet:

Position the faucet and sealing ring on top of the mounting surface. From beneath, install the plastic washer, slide washer and metal washer. Thread on the collar nut loosely.

If the total thickness of the mounting surface is greater than $1\frac{3}{8}$ " , omit the plastic washer.

Inspect the placement of the faucet. Reposition if necessary.

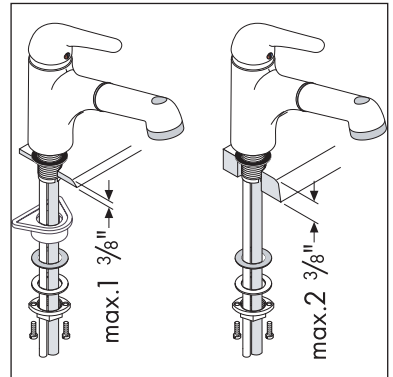

The spout should swivel equally to the right and to the left. If it appears to swivel more to one side than to the other, pivot the faucet body until the swivel is even.

When you are satisfied that everything is oriented properly, finish tightening the collar nut. Tighten the tensioning screws.

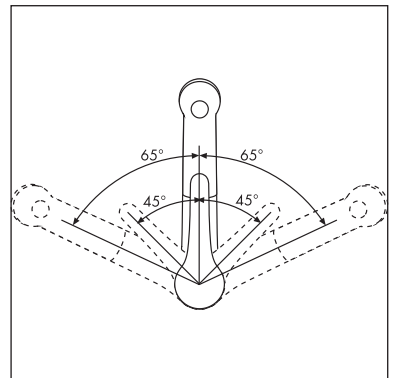

Connect the handspray hose:

Loosen the compression fitting on the end of the flexible handspray hose. Slide it onto the end of the handspray supply hose.

While holding the hose still with a 12 mm wrench, tighten the nut with a 17 mm wrench.

DO NOT ALLOW THE HOSE TO TWIST. IF THE HOSE TWISTS, THE FLOW FROM THE SPRAYHEAD MAY BE REDUCED.



Connect the supplies:

Connect the hot and cold supply hoses to the supplies with 3/8" compression fittings (not included). Tighten them wrench tight.

Use two wrenches, as shown in the diagram. Do not allow the hot and cold supply hoses to twist.

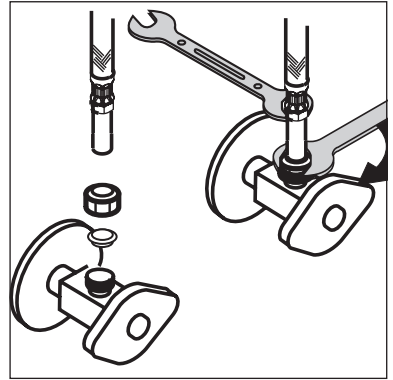

Install the hose weight:

Proper installation of the hose weight will insure that the handspray hose retracts smoothly.

On the handshower side of the hose, use a ruler to measure 15" down from the body of the faucet. Install the hose weight at this point.

Pull out on the handspray and guide it back into the faucet. It should move easily and retract smoothly. Reposition the hose weight if necessary.

Turn on the water. Check all connections for leaks. Check the faucet for proper operation.

Set the High Temperature Limit Stop (optional):

Turn off the water at the supply stops.

Close the drain or cover it with a cloth. Gently pry off the screw cover. Put it aside in a safe place. Use a 4mm hex wrench to loosen the handle screw (4 revolutions). Remove the handle and the decorative flange underneath.

Remove the nut.

Remove the handle screw from the stem of the cartridge.

Remove the high temperature limit stop.

Replace the high temperature limit stop so that the pin is in the desired notch. The temperatures marked on the diagram assume an incoming hot water temperature of 140° F and an incoming cold water temperature of 50° F and a water pressure of 45 psi. Your results will vary.

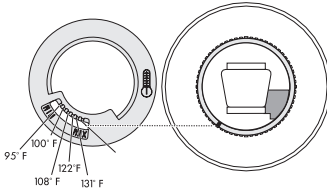

Replace the nut, nut cover, screw and handle.

User Instructions

Turn the water on by raising the handle. Lower the handle to turn the water off. Pivot the handle to the right for cooler water, to the left for warmer water.

When the faucet is turned on, the sprayhead is in the stream mode. Press the button on top of the sprayhead to activate the spray mode. When the water is turned off, the sprayhead will revert to the stream mode.

The spray channels on the handspray use the Rubit™ cleaning system. If mineral deposits are noticed in the spray channels, turn the water on lightly and wipe the spray channels with your thumb or with a cloth.

If the flow of water diminishes over time, remove and clean the filter, located at the end of the handspray hose.

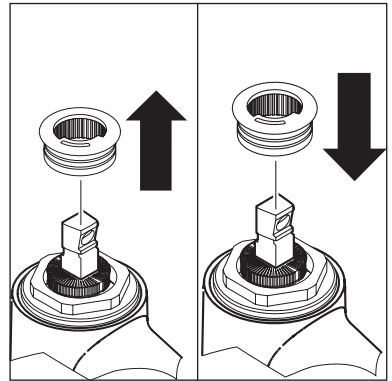
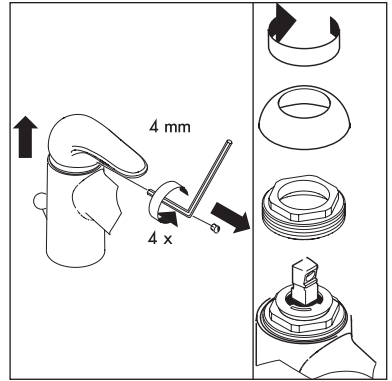

Replacement Parts:

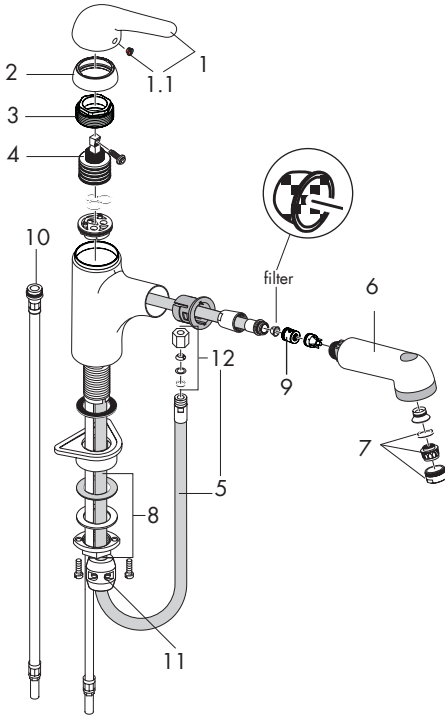

1.	handle	35891800
1.1	screw cover	94186000
2	flange	97650800
3	nut	94194000
4	M3 cartridge	92730000
5	hose	95048000
6	handspray	35893800
7	aerator	97691000
8	mounting set	95049000
9	check valve	97350000
10	connection hose	96510000
11	hose weight	98551000
12	squeezing connection	96099000

Cleaning Recommendation for Hansgrohe Products

Modern lavatory faucets, kitchen faucets and showers consist of very different materials to comply with the needs of the market with regard to design and functionality. To avoid damage and returns, it is necessary to consider certain criteria when cleaning.

Cleaning Materials for Faucets and Showers

Acids are a necessary ingredient of cleaning materials for removing lime, however please pay attention to the following points when cleaning faucets and showers:

- Only use cleaning materials which are explicitly intended for this type of application.
- Never use cleaning materials which contain hydrochloric, formic, phosphoric, or acetic acid, as they cause considerable damage.
- Never mix one cleaning material with another.
- Never use cleaning materials or appliances with an abrasive effect, such as unsuitable cleaning powders, sponge pads, or micro fiber cloths.

Cleaning Instructions for Faucets and Showers

Please follow the cleaning material manufacturer's instructions. In addition, pay attention to the following points:

- Clean the faucets and showers as and when required
- Use the amount of cleaning product and the amount of time recommended by the manufacturer. Do not leave the cleaner on the fixture longer than necessary.
- Regular cleaning can prevent calcification.
- When using spray cleaners, spray first onto a soft cloth or sponge. Never spray directly onto the faucet as droplets can enter openings and gaps and cause damage.
- After cleaning, rinse thoroughly with clean water to remove any cleaner residue.

Important

Residues of liquid soaps, shampoos and shower foams can also cause damage, so rinse with clean water after using.

Please note: if the surface is already damaged, the effect of cleaning materials will cause further damage.

Components with damaged surfaces must be replaced or injury could result. Damage caused by improper treatment is not covered under the warranty.

Limited Lifetime Consumer Warranty

This product has been manufactured and tested to the highest quality standards by Hansgrohe, Inc. ("Hansgrohe"). This warranty is limited to Hansgrohe products which are purchased by a consumer in the United States after March 1, 1996 and installed in either the United States or Canada.

WHO IS COVERED BY THE WARRANTY

This warranty extends to the original consumer purchaser only. This warranty is non-transferable.

WHAT IS COVERED BY THE WARRANTY

This warranty covers only your Hansgrohe manufactured product. Hansgrohe warrants this product against defects in material or workmanship as follows: Hansgrohe will repair at no charge for parts only or, at its option, replace any product or part of the product that proves defective because of improper workmanship and/or material, under normal installation, use, service and maintenance. If Hansgrohe is unable to provide a replacement and repair is not practical or cannot be timely made, Hansgrohe may elect to refund the purchase price in exchange for the return of the product.

LENGTH OF WARRANTY

Replacement or repaired parts of products will be covered for the term of this warranty as stated in the following two sentences. If you are a consumer who purchased the product for use primarily for personal, family, or household purposes, this warranty extends for as long as you own the product and the home in which the product is originally installed. If you purchased the product for use primarily for any other purpose, including, without limitation, a commercial purpose, this warranty extends only (i) for 1 year, with respect to Hansgrohe and Commercial products and (ii) for 5 years, with respect to AXOR products.

THIS WARRANTY DOES NOT COVER and HANSGROHE WILL NOT PAY FOR:

- A. Conditions, malfunctions or damage not resulting from defects in material or workmanship.
- B. Conditions, malfunctions or damage resulting from (1) normal wear and tear, improper installation, improper maintenance, misuse, abuse, negligence, accident or alteration, or (2) the use of abrasive or caustic cleaning agents or “no-rinse” cleaning products, or the use of the product in any manner contrary to the product instructions. (3) Conditions in the home such as excessive water pressure or corrosion.
- C. Labor or other expenses for the disconnection, deinstallation, or return of the product for warranty service, or for installation or reinstallation of the product (including but not limited to proper packaging and shipping costs), or for installation or reinstallation of the product.
- D. Accessories, connected materials and products, or related products not manufactured by Hansgrohe.

TO OBTAIN WARRANTY PARTS OR INFORMATION

Contact your Hansgrohe retailer, or contact Technical Service at:

Hansgrohe Inc.
1492 Bluegrass Lakes Parkway
Alpharetta GA 30004
Toll-free (800) 334-0455.

In requesting warranty service, you will need to provide

- 1. The sales receipt or other evidence of the date and place of purchase.
- 2. A description of the problem.
- 3. Delivery of the product or the defective part, postage prepaid and carefully packed and insured, to Hansgrohe Inc. 1492 Bluegrass Lakes Parkway, Alpharetta, Georgia 30004, Attention: Technical Service, if required by Hansgrohe.

When warranty service is completed, any repaired or replacement product or part will be returned to you postage prepaid.

EXCLUSIONS AND LIMITATIONS

REPAIR OR REPLACEMENT (OR, IN LIMITED CIRCUMSTANCES, REFUND OF THE PURCHASE PRICE) AS PROVIDED UNDER THIS WARRANTY IS THE EXCLUSIVE REMEDY OF THE PURCHASER. HANSGROHE NEITHER ASSUMES NOR AUTHORIZES ANY PERSON TO CREATE FOR IT ANY OBLIGATION OR LIABILITY IN CONNECTION WITH THIS PRODUCT.

HANSGROHE SHALL NOT BE LIABLE TO PURCHASER OR ANY PERSON FOR ANY INCIDENTAL, SPECIAL, OR CONSEQUENTIAL DAMAGES, ARISING OUT OF BREACH OF THIS WARRANTY OR ANY IMPLIED WARRANTY (INCLUDING MERCHANTABILITY).

Some States do not allow the exclusion or limitation of incidental or consequential damages, so the above limitation or exclusion may not apply to you. This warranty gives you specific legal rights and you may have other rights which vary from State to State. You may be required by law to give us a reasonable opportunity to correct or cure any failure to comply before you can bring any action in court against us under the Magnuson-Moss Warranty Act.

PRODUCT INSTRUCTIONS AND QUESTIONS

Upon purchase or prior to installation, please carefully inspect your Hansgrohe product for any damage or visible defect. Prior to installing, always carefully study the enclosed instructions on the proper installation and the care and maintenance of the product. If you have questions at any time about the use, installation, or performance of your Hansgrohe product, or this warranty, please call or write to us or call us toll-free at 800 334 0455.

hansgrohe

Hansgrohe, Inc. • 1490 Bluegrass Lakes Parkway • Alpharetta, GA 30004
Tel. 770 360-9880 • Fax 770 360 9887

www.hansgrohe-USA.com