



Elizabethan Classics

Specification for ECGDSLRLM

Hole	Diameter
Drain	2" +/- 1/8
Over Flow	2-1/4" +/- 3/16
Faucet	1-3/8" +/- 1/8
Capacity	55.7 US Gallon
Weight of Tub	310 lbs
Weight of Tub filled with water	774 lbs
Bathing well	48-7/8" X 22-1/4"

Top View

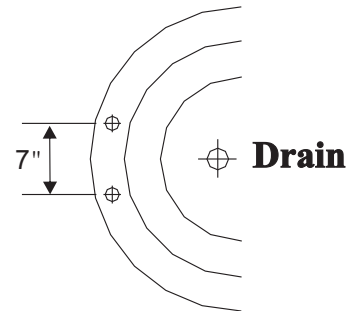
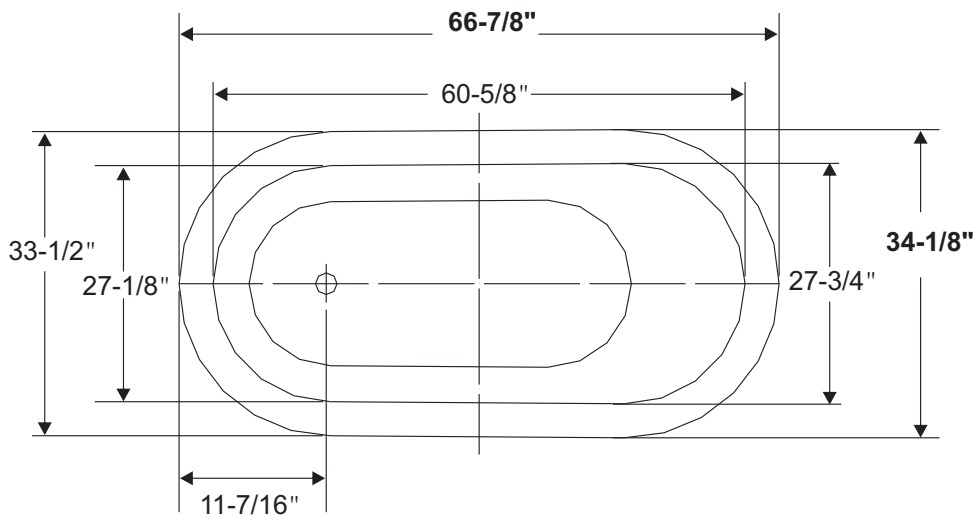

FSMS Feet Placement Diagram

