



## SHCM-23580

### SHOWER COLUMN INSTALLATION INSTRUCTIONS

#### IMPORTANT

DreamLine™ reserves the right to alter, modify or redesign products at any time without prior notice. For the latest up-to-date technical drawings, manuals or any other details please refer to the [support.BathAuthority.com](http://support.BathAuthority.com) web page.



Please read these instructions carefully before installing. If you have any questions regarding installation, please call our technical support specialists Monday through Friday 9:00 AM – 5:00 PM EST at Phone: [1-866-731-2244](tel:1-866-731-2244), Fax: [1-866-227-1533](tel:1-866-227-1533) or e-mail our technical support group at [support@BathAuthority.com](mailto:support@BathAuthority.com).

For more information on [DreamLine™ Shower Columns](http://www.BathAuthority.com) please visit [www.BathAuthority.com](http://www.BathAuthority.com)

## Parts List:



2, 18	Wall anchors	6pcs	13, 14	Water supply hoses	2pcs
3	Mounting Brackets	2pcs	21	Hand shower wall mounting bracket	1pc
4	Stainless Steel washers	8pcs	22	Hand shower	1pc
5, 20	Mounting Screws	6pcs	24	59" flexible shower hose kit	1pc
6	Shower arm	1 pc	31	Corner mounting bracket (used for corner installation)	2pcs
9, 23	Rubber washers (used together with parts # 10,11,24)	3pcs	32	Soap dish	1pc
10	L-Fitting	1pc	33	Rubber gaskets	2pcs
11	Shower head	1pc	34	Holder used together with mounting brackets for flat wall installation	2pcs

## Preparation

1. After opening all boxes and packages, read this introduction carefully. Check that all of the needed parts are included in the package by marking all the components on the "Detailed Diagram of Shower Door Components". Examine boxes and packages for shipping damage. If the unit has been damaged, has a finishing defect, or has missing parts, please contact our customer support department within 5 business days of the delivery date. Please note that **DreamLine™ will not replace any damaged products or missing parts free of charge after 5 business days or if the product has been installed.** Feel free to contact DreamLine™ if you have any questions.
2. **Please note that you should consult your local building codes with questions on installation compliance standards. Building and plumbing codes may vary by location, and DreamLine is not responsible for code compliance standards for your project and will not accept any returns.**
3. If this unit is going to be installed in a new construction, please, install all of the required plumbing and drainage before installing the shower. **Use a competent and licensed (if required by local code) plumber for all plumbing installation**

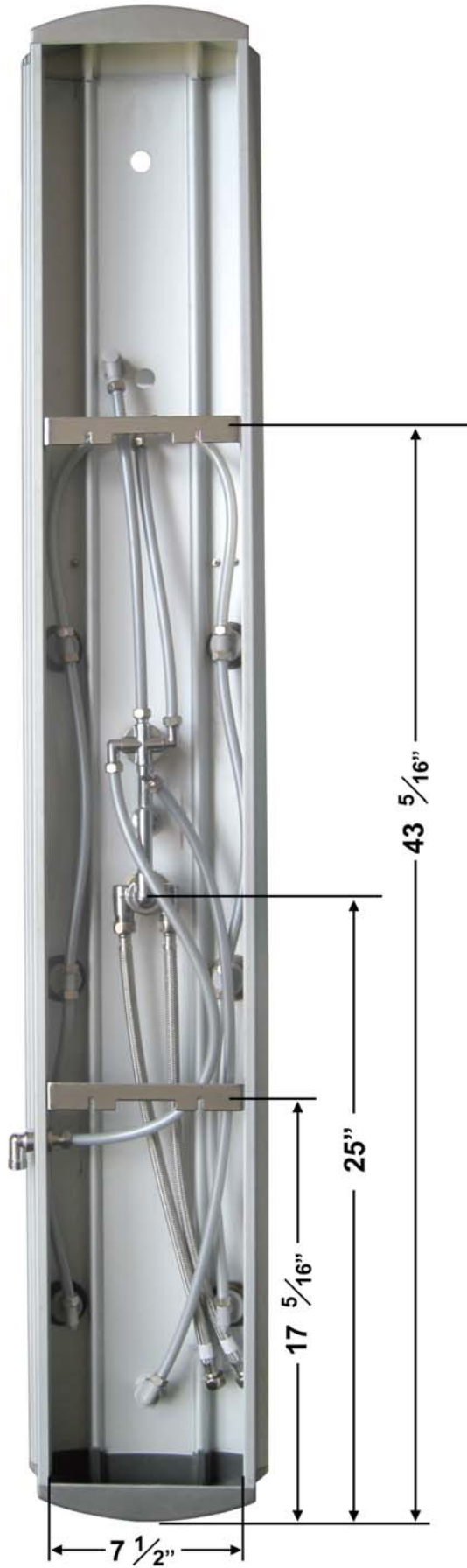

# Technical specifications

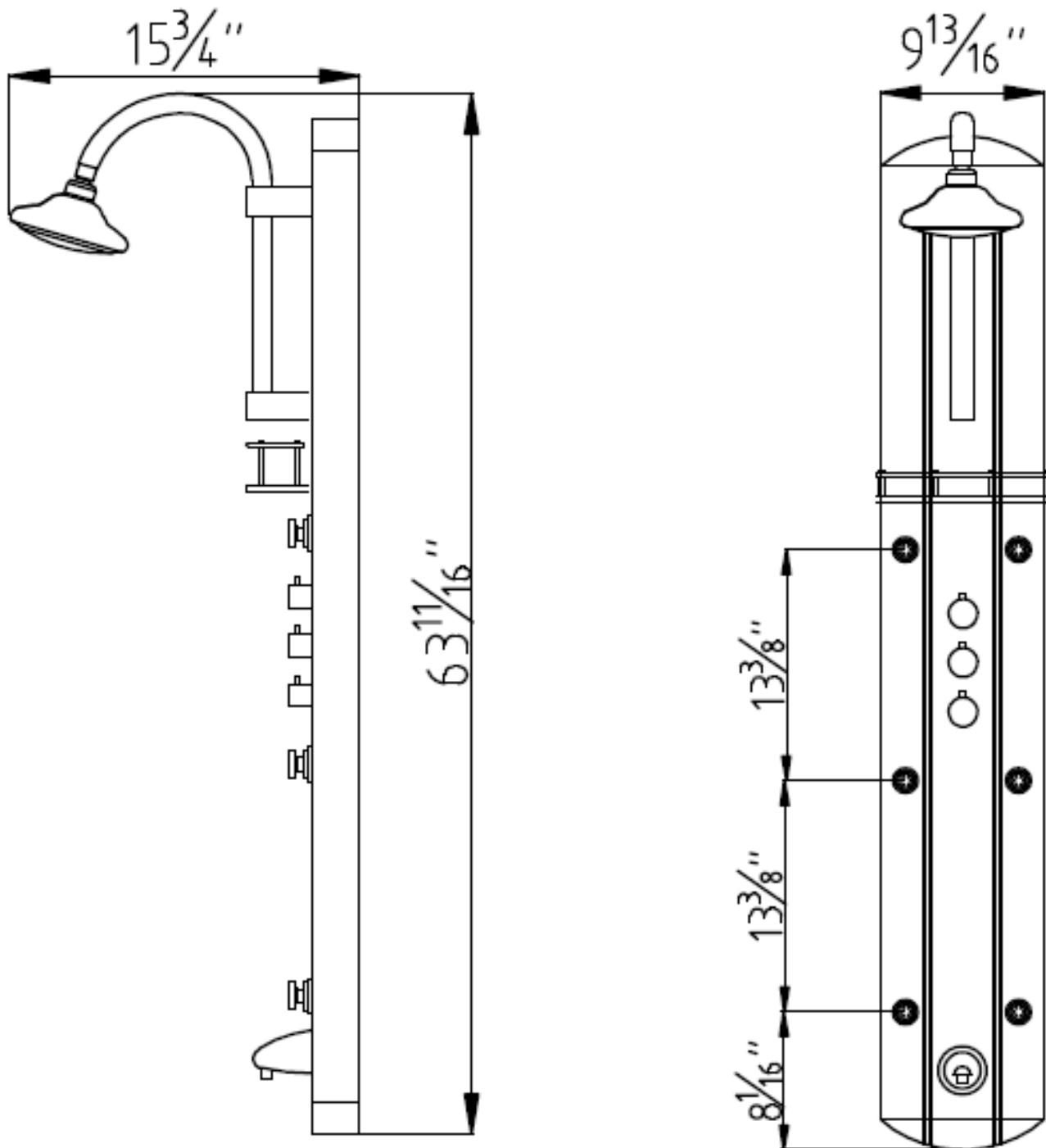

Technical Diagram

# Installation procedure

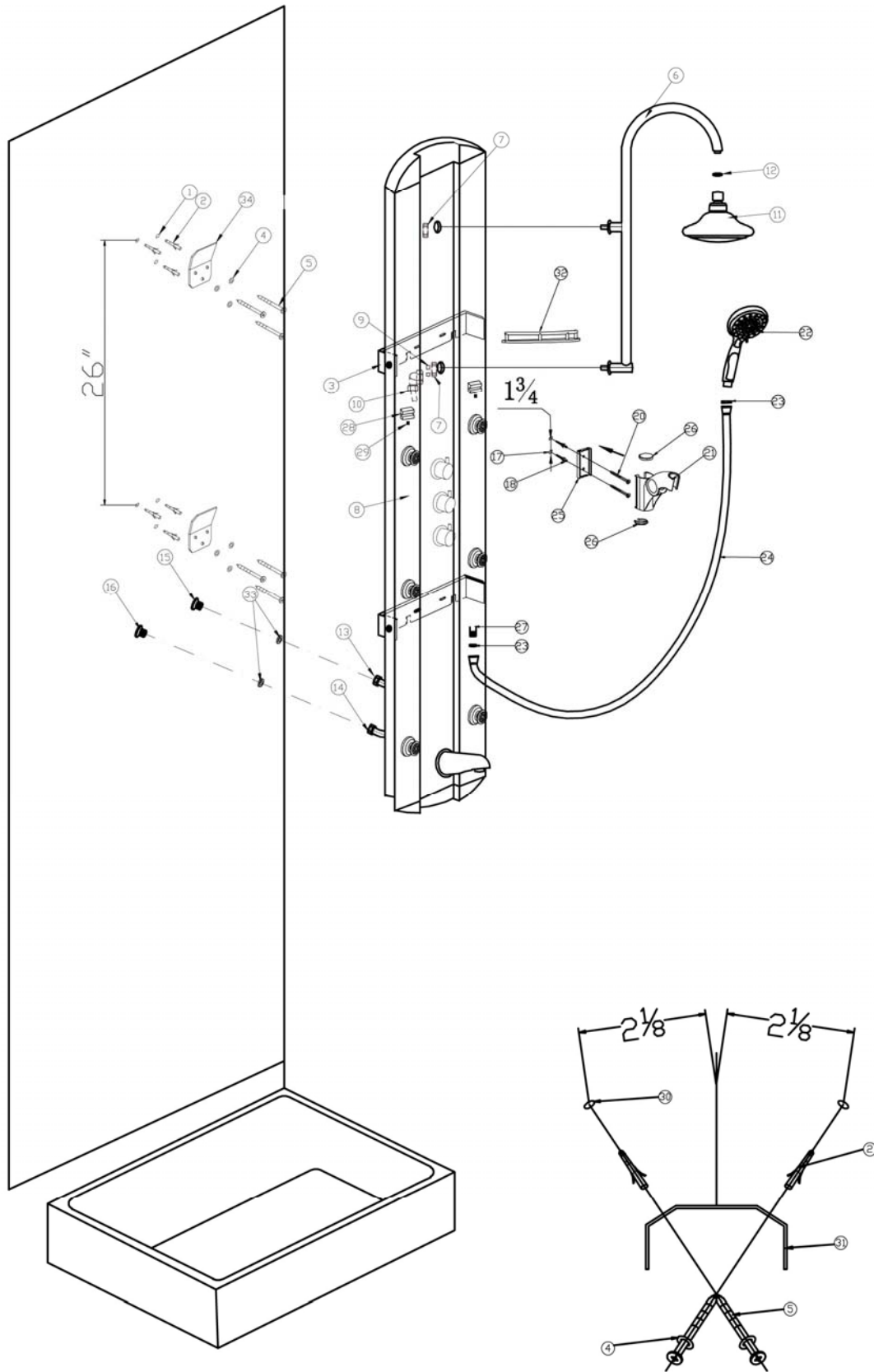

## Column Installation

Refer to the technical diagram to choose the proper location for your shower column. You can adjust the column's vertical position based on the person's height. (Measurements given in the technical diagram are based on the average human height – 68"-70").

1. Secure the shower arm (6) on to the column (8) using nuts (7).
2. Place gasket (9) into L-fitting (10).
3. Connect L-fitting (10) with Shower arm (6).
4. Place rubber washer (12) into the Shower head (11).
5. Connect the Shower head (11) to the Shower arm (6).
6. Choose the proper location for your column and mark the drill holes (1). Drill the holes on the distance 4 ¼" from each other and on the distance 270 mm from upper holes to lower holes.
7. Insert Wall anchors (2) inside the holes.
8. Tighten the screws (5) in the holders(34) for mounting brackets(3)to the wall with stainless steel washers (4).
9. Placing the rubber gasket (33) inside the flexible hot(13) and cold(14) water supply lines.Connect the flexible hot (13) and cold (14) water supply lines to hot (15) and cold (16) water outlets (supplied by your plumber) accordingly.
10. Hang the Mounting brackets (3) on the holders (34) secured in the wall.
11. Securing the Hand shower bracket: Place bracket (21) against wall in place you want to install hand shower and mark the drill holes (17). Drill the holes. Insert Wall anchors (18) into the holes.
12. Secure the Hand shower bracket (21) to the wall by screws (20).
13. Attach the flexible shower hose (24) to the column body. NOTE: do not forget to use the rubber washer (23) to prevent leakage on the connection. Flexible hose end with a nut should be attached to the column.
14. Connect the hand shower (22) to the hose (24) placing the rubber washer (23) in the fastening nut and tight it by hands.

## Corner installation

For Corner installation you need to install Corner mounting bracket (31). Refer to the technical diagram to choose the proper location for your shower column. You can adjust the column's vertical position based on the person's height. (Measurements given in the technical diagram are based on the average human height – 68"-70").

1. Choose the proper location for your column and mark the drill holes (30). Drill the holes on the distance 2 ¼" from corner.
2. Insert Wall anchors (2) inside the holes.
3. Attach Corner mounting bracket to the wall using screws (5) with stainless steel washers (4).

The rest of the installation procedure is the same as flat wall mounting.

Please, make sure that none of the hoses are bent or kinked after final installation. Check water connections for proper flow; make sure there is no leakage.

## Using controls:

- Valve “a” turns on water of the top shower head, the hand shower, the massage jets and the spout.
- Valve “b” turns on water volume.
- Thermostatic valve “c” adjusts water temperature on any valves you are using. To pass behind 100 degrees point, you will need to push the button down and turn the handle CCW.

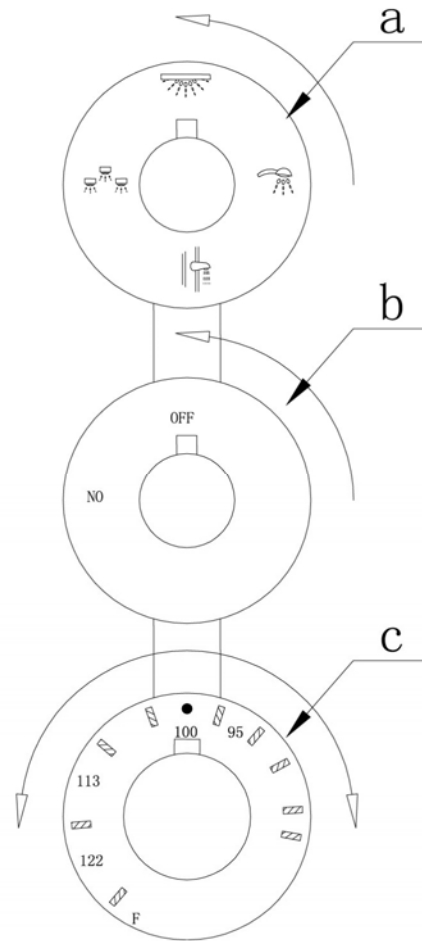



## DREAMLINE™ EXCLUSIVE LIMITED WARRANTY AS OF MAY 6, 2013

This warranty extends only to the original owner/end-user for household use only and is not transferable to a subsequent owner. This warranty extends for a designated period of time, so long as it remains in use in its original place of installation. This warranty applies only to DreamLine products purchased from an authorized dealer in United States or Canada. Proof of purchase (original sales receipt) from the original consumer purchase must be provided with all warranty claims.

### **IN NO EVENT SHALL THE LIABILITY OF DREAMLINE EXCEED THE PURCHASE PRICE OF THE UNIT.**

DreamLine products must be installed by a fully insured and licensed professional. Installation of DreamLine product by anyone other than fully insured licensed professionals shall **VOID THE WARRANTY**. DreamLine recommends that such licensed professionals have experience in the installation of bathroom products. Installation of certain products, including, without limitation, glass products (i.e., shower and tub doors) by an inexperienced installer may result in glass breakage and, consequently, cause personal injury or death.

### **PARTS ONLY WARRANTY**

This warranty is extensive in that it covers replacement of all defects. LABOR CHARGES AND/OR DAMAGE INCURRED IN INSTALLATION, REPAIR, OR REPLACEMENT, AS WELL AS ANY OTHER KIND OF LOSS OR DAMAGE ARE EXCLUDED

### **COMMERCIAL USE AND OTHER EXCLUSIONS**

This warranty excludes all industrial, commercial and business usage, whose purchasers are hereby extended a one (1) year limited warranty from the date of purchase for shower and tub doors, a three (3) month limited warranty from the date of purchase for vanities and sinks, with all other terms of this warranty applying except the duration of the warranty.

DREAMLINE JETTED AND STEAM SHOWER CABINS, DREAMLINE SHOWER COLUMNS AND DREAMLINE SHOWER SEATS ARE NOT INTENDED FOR COMMERCIAL USE AND THERE IS NO WARRANTY EXTENDED FOR THESE PRODUCTS FOR COMMERCIAL USE.

DreamLine hereby disclaims all warranties for products sold as dealer or store displays. DreamLine hereby disclaims all warranties for products used outside of the United States or Canada whether expressed or implied, including but not limited to the implied warranties of merchantability and fitness for a particular purpose.

### **WARRANTY TERMS**

DreamLine will, at its election, repair or replace the product found by DreamLine in its sole judgment, to be defective within the warranty period under normal residential use and maintenance. The replacement of a product is limited to supplying a replacement product or part (same as existing or if not available, comparable product). DreamLine warranty obligation shall be discharged upon tender of parts, replacement or repair of the product. Purchaser's refusal to accept the tender terminates all warranty obligations and **VOIDS THE WARRANTY**. Cost of freight for returning products to DreamLine for repairs or replacement under this limited warranty are the responsibility of the customer. Cost of freight associated with shipping of replacement product or parts to the customer may be charged to customer. Any product replaced or repaired during the warranty period will be covered only for the remaining period of the original warranty. In no event will DreamLine be liable for costs of repair or replacement of any installation material, including but not limited to tiles, marble, etc.

### **DREAMLINE IS NOT RESPONSIBLE FOR INSTALLATION, REMOVAL OR REINSTALLATION COSTS OF ANY PRODUCT REQUIRING WARRANTY SERVICES.**

Any modification or alteration of any DreamLine products will void the warranty. DreamLine product installations and repairs must be performed by either a DreamLine authorized agent or a licensed, insured and experienced professional contractor - installation or repairs performed by any other party shall void the warranty. This warranty shall not apply to breakage or damages caused by normal wear and tear, fault, carelessness, abuse, misuse, misapplication, improper maintenance, alteration or modification of the unit, as well as chemical or natural corrosion, accident, fire, flood, act of God or any other casualty. Improper care and cleaning will void the warranty. Use of cleaners containing abrasive cleansers, ammonia, bleach, acids, waxes, alcohol, solvents or other products not recommended for chrome or similar finish, glass or acrylic will void the warranty. For additional product maintenance instructions please refer to product installation manual. DreamLine is not responsible for any issues arising in connection with errors or omissions in information provided on DreamLine's websites. The warranty does not extend to any non-DreamLine plumbing or components installed by installers, end users or by any party other than DreamLine.

**THE FOREGOING WARRANTIES ARE IN LIEU OF ALL OTHER WARRANTIES, EXPRESSED OR IMPLIED, INCLUDING BUT NOT LIMITED TO THE IMPLIED WARRANTIES OF MERCHANTABILITY AND FITNESS FOR A PARTICULAR PURPOSE. BATH AUTHORITY LLC ("DREAMLINE") AND/OR SELLER DISCLAIMS ALL LIABILITY FOR SPECIAL, INCIDENTAL OR CONSEQUENTIAL DAMAGES. DREAMLINE IS NOT LIABLE FOR PERSONAL INJURIES OR DEATH TO ANY PERSON OR FOR ANY DIRECT, SPECIAL, INCIDENTAL OR CONSEQUENTIAL DAMAGE, LOSS OF USE, LOSS OF TIME, LOSS OF PROFITS, INCONVENIENCE, INCIDENTAL EXPENSES, LABOR OR MATERIAL CHARGES, OR ANY OTHER COSTS RESULTING FROM THE USE OF ITS PRODUCTS OR PERTAINING TO THE APPLICATION OF THE PRESENT WARRANTY, OR RESULTING FROM THE REMOVAL OR REPLACEMENT OF ANY PRODUCT OR ELEMENT OR PART COVERED BY THIS WARRANTY.**

### **PRODUCT WARRANTY PERIODS**

DreamLine is not responsible for product code compliance or for verifying building code restrictions on installation or use and any such compliance is excluded from this warranty. DreamLine reserves the right to modify this warranty at any time - such warranty modifications will not alter the warranty applicable at the time of sale of the products in question. The warranty terms for specific products for consumer (non-industrial, non-commercial, non-business use only) are:

#### **SHOWER BACKWALL, SHOWER CABINS (JETTED & STEAM)**

DreamLine warrants shower backwalls and shower cabins to be free from defects in workmanship for a period of one (1) year from initial date of purchase by the owner/end-user, contractor or builder from an authorized dealer.

#### **SHOWER & TUB DOORS, SHOWER ENCLOSURES**

DreamLine warrants shower doors, tub doors and shower enclosures to be free from defects in workmanship and materials under normal residential use for a period of five (5) years from the initial date of purchase by the owner/end-user, contractor or builder from an authorized dealer. Warranty for plastic strips shall be limited to one (1) year. Warranty for any part in Oil Rubbed Bronze finish shall be limited to one (1) year.

#### **SHOWER BASES**

DreamLine warrants shower bases to be free from defects in workmanship and materials under normal residential use for as long as the original consumer purchaser owns their home in which their product is installed.

#### **SHOWER COLUMNS**

DreamLine warrants shower columns to be free from defects in workmanship and materials under normal residential use for a period of one (1) year from the initial date of purchase by the owner/end-user, contractor or builder from an authorized dealer.

#### **SHOWER SEATS**

DreamLine warrants shower seats to be free from defects in workmanship and materials under normal residential use for a period of one (1) year from the initial date of purchase by the owner/end-user, contractor or builder from an authorized dealer. Warranty shall be VOID if the shower seat is not professionally installed on a properly reinforced wall.

#### **VANITIES AND VESSEL SINKS**

DreamLine warrants bathroom vanities and vessel sinks to be free from defects in workmanship and materials under normal residential use for a period of one (1) year from the initial date of purchase by the owner/end-user, contractor or builder from an authorized dealer.

#### **STATE LAWS AND THIS WARRANTY**

Some states/provinces do not allow limitations on how long an implied warranty lasts, or the exclusion or limitation of special, incidental or consequential damages, so these limitations and exclusions may not apply to you. This warranty gives you specific legal rights. You may also have other rights, which vary from state/province to state/province.

### **WARRANTY SERVICE**

The following information will be required for you to file a Warranty claim:

1. Your name, address and telephone number
2. Product model number
3. Brief description of problem (please note that additional information such as photos may be required to fully process your warranty claim)
4. Proof of purchase

You may submit this information by e-mail, mail or fax to:

DreamLine  
Warranty Service Center  
75 Hawk Road  
Warminster, PA 18974  
F:1-866-857-3638  
T:1-866-731-2244

[Warranty@bathauthority.com](mailto:Warranty@bathauthority.com)



---

TEL: [866-731-2244](tel:866-731-2244)

FAX: [866-227-1533](tel:866-227-1533)

[WWW.BATHAUTHORITY.COM](http://WWW.BATHAUTHORITY.COM)

For more information on [DreamLine™ Shower Columns](http://www.BathAuthority.com) please visit [www.BathAuthority.com](http://www.BathAuthority.com)