

Montclair One Door Two Drawer Vanity



Specifications

- Solid wood door frames and drawer fronts
- Quality Chestnut Glaze finish highlights the elegant door design
- Full extension ball bearing drawer glides
- Oil rubbed bronze hardware with TruMatch™ finish
- Durable water-resistant finish
- Reversible door can open to the left or right
- Vanity top sold separately



Dimensions

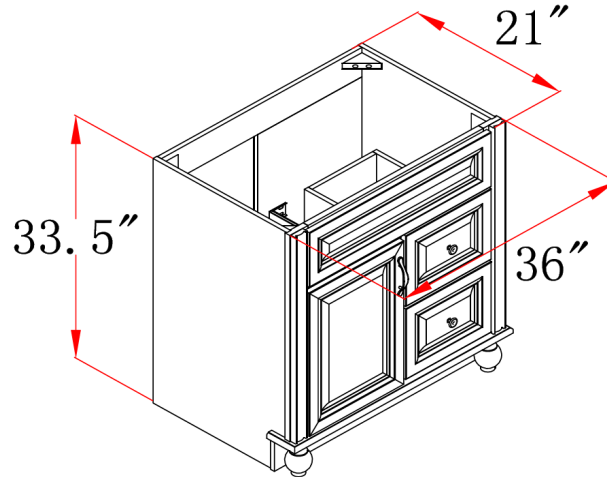

Warranty & Compliances

Warranty Limited 1 year warranty
California 93120 Compliant



Order Codes & Finishes/Colors

	Fully Assembled	Ready to Assemble
36"w x 21"d x 33.5"h	538553	540732

Type:
Job:
Order Code:
Approvals:

Design House reserves the right to make changes in materials, specifications & models at any time. Design House also reserves the right to discontinue product without notice or obligation.