



150__T4__ __

Write purchase model number here for future reference

206281
206281
206281
206281
206281

NOTE: For optimum performance of this product, we recommend a system pressure between 20 and 80 PSI static. This product will operate up to a maximum of 125 PSI static per ANSI and CSA requirements. However, we do not recommend pressure above 80 PSI. Thermal expansion or leaking pressure reducing valves may require use of expansion tanks or relief valves to ensure your system never exceeds its maximum intended pressure setting.

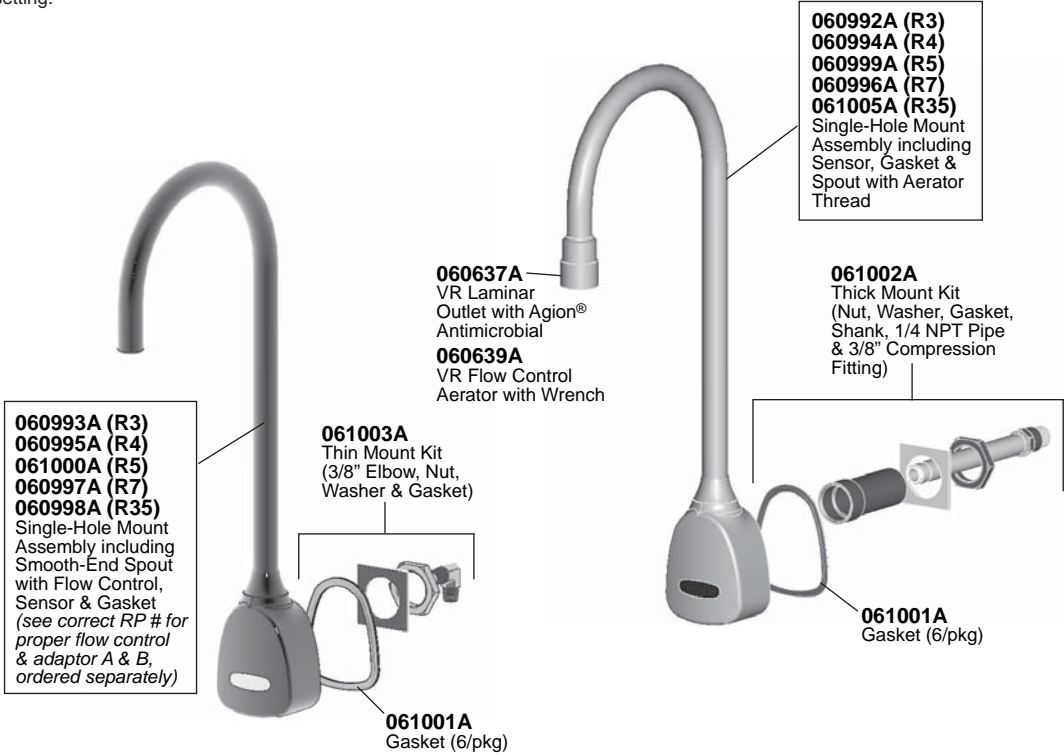

206281
206281
206281
206281
206281

OPTION LIST

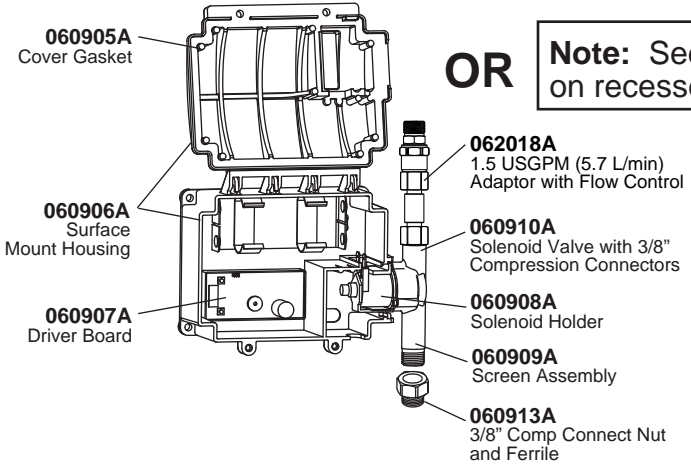
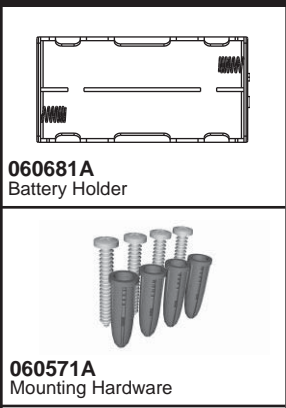

OR Note: See page 3 for parts breakdown on recessed mount boxes.

- 060690A**
36" Cable Extension
- 060416A**
Bypass Adaptor
- RP30523**
Braided Hose
- 060683A**
24VAC to 6VDC Converter

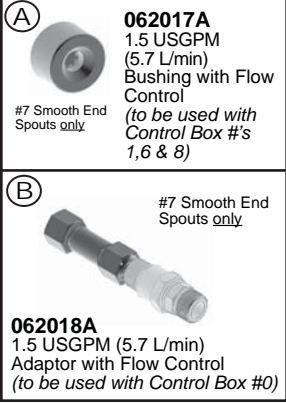

*Package Quantities May Change.
Check the Parts section of the latest Delta Commercial Faucet Price List for current quantities.

PLEASE LEAVE this M&I Sheet with the owner, maintenance plumber, etc. as items relating to ongoing maintenance suggestions and procedures are included.

Installation should be in accordance with local plumbing and electrical codes.
FLUSH ALL PIPES THOROUGHLY BEFORE INSTALLATION.

INSTALLATION AND SET UP INSTRUCTIONS

FOR SURFACE MOUNT HOUSING: CONTROL BOX #0

STEP 1. FAUCET INSTALLATION

Depending on the installation, use the 061003A thin wall kit OR 061002A thick wall kit (both provided as standard). Connect 20" braided hose to spout inlet. Clean surface where faucet will be mounted. Install faucet to sink/wall using nut and washer provided. Ensure gasket is centered on faucet prior to tightening. Do not over-tighten the nut or reposition the faucet once installed, otherwise damage to the gasket may result. Cutting or trimming of the gasket is not recommended. If the gasket is trimmed or modified, then clear silicone sealant should be used between the faucet and sink/wall surface to prevent water leakage.

STEP 2. BATTERY BOX INSTALLATION

Mount battery box to wall under sink using the 4 supplied screws and anchors. Use 1/4" drill for wall anchors. **Be sure to install the box within the dimensions provided so the hose and spout cable will reach connections at faucet and battery box. Refer to illustration (Fig. 2).**

STEP 3. FLUSH SYSTEM

To flush supply line, assemble these components as shown (Fig. 3) and run water for 1 minute. Shut off water supply. Attach aerator or flow control with adapter for #7 smooth end spouts. **NOTE:** Do not connect supply to the solenoid inlet until line is flushed directly out spout.

STEP 4. CONNECT WATER SUPPLY

Disassemble the components, reassemble the ones shown here (Fig. 4) supply line and adaptor to the bottom fitting on box, braided hose to the top fitting on box. Use plumber tape where indicated on adaptor. **DO NOT SOLDER CONNECTIONS!**

STEP 5. POWER UP

Unscrew the battery box lid screws (2). Install 4 "C" batteries in holder or snap the battery clip directly to the optional 24 VAC converter.

⚠ BATTERY VERSION Install four "C" batteries provided into the battery holder. After the batteries are installed, make the sensor connection on the driver board neatly inside the battery box. Connect battery clip to battery pack. One beep should occur to indicate power is applied. Two beeps indicate product is ready to use. Use caution not to damage wires or components on electronic driver board. See Fig 5. Secure lid using screws.

⚠ HARDWIRE VERSION Install CSA and/or UL approved Class 2 transformer or equivalent in a convenient location or in a pipe chase. **(Do NOT install the transformer inside the control box.)** With the power off, bring the 24 VAC supply wires to the box. Connect the 24 VAC supply to the 060683A conversion kit, (see page 1). Connect the battery snap of the hardwire converter to the driver board battery clip. Ensure snap does not touch box or other metal surface. Turn on power supply for the transformer and then make the sensor connection on the control module neatly inside the battery box.

STEP 6. TIE SPOUT CABLE

Attach spout cable to box connector. Use tie wraps to secure spout cable to spout hose. Your faucet is now ready for use (Fig. 2).

STEP 7. TEST FOR OPERATION

Test for operation. If faucet leaks from spout outlet: **SHUT OFF WATER SUPPLIES.** Replace Battery Box or Solenoid Assembly (1). If faucet exhibits very low flow: A) Remove and clean spray outlet or flow control, or B) **SHUT OFF WATER SUPPLY.** Clean or replace screen assembly (2). If unit does not work properly, see Trouble Shooting Guide on page 6.

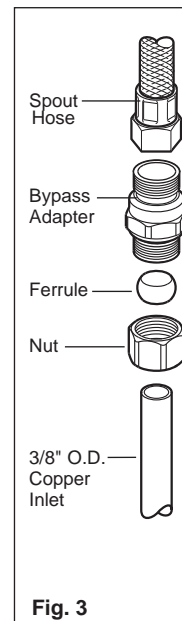
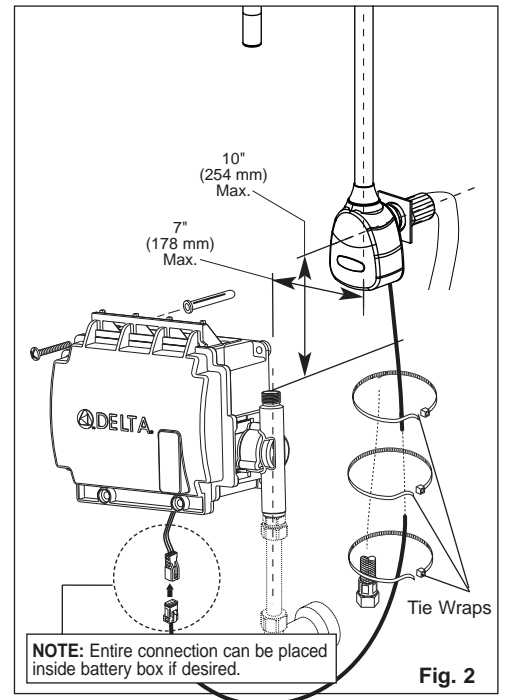

Fig. 3

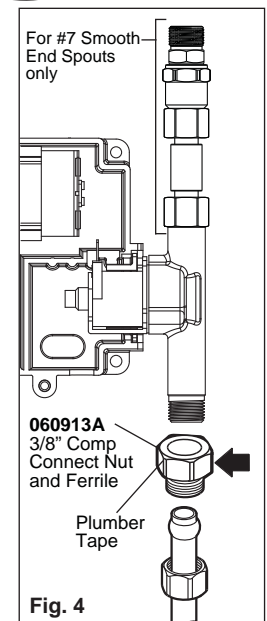

Fig. 4

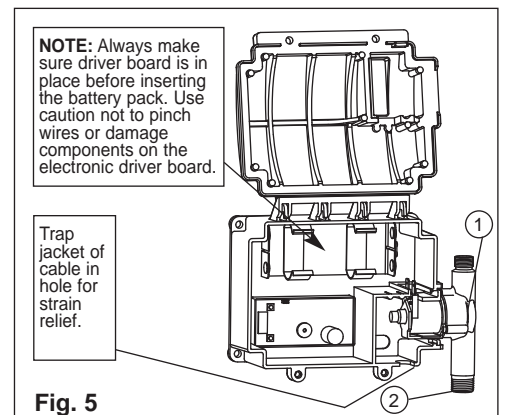

Fig. 5

**Installation should be in accordance with local plumbing and electrical codes.
FLUSH ALL PIPES THOROUGHLY BEFORE INSTALLATION.**

INSTALLATION AND SET UP INSTRUCTIONS

FOR RECESS MOUNT HOUSING: CONTROL BOXES #1, 6, 8.

STEP 1. ROUGH IN

HARDWARE Remove suitable knockout(s) in box(es) and insert cable bushing(s). See Fig. 6.

Note: Wires connecting between box(es) and from transformer must be protected from abrasion, and being pulled at connections. They also may have to be fished through at a later stage of construction. Depending on installation, the cable bushings included may be replaced by **installer supplied** 1/2" conduit. Rough-in box as per Fig. 10.

The transformer is to be installed in an adjacent accessible space. (**Do NOT install the transformer inside the control box.**) Cable from the transformer to the driver board may be roughed in at this time depending on installation. Use cable which complies to local electrical codes for 1 amp load. No. 18 is usually sufficient.

HARDWARE OR BATTERY If recessed box is supplied, rough in as per Fig. 10. The most vandal resistant installation is when the control box is as close to the bottom of the sink as feasible. For wall hung sink installation, sensor conduit rough in should be directly under the basin. Rough in drainage. Rough in water supply to 10" control box inlets and to spout connection. Finish walls.

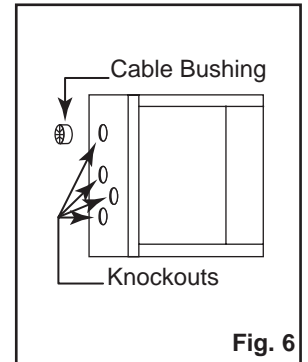

Fig. 6

STEP 2. FAUCET INSTALLATION

Depending on the installation, use 061003A thin wall kit OR 061002A thick wall kit (both provided as standard). Clean surface where faucet will be mounted. Install faucet to sink/wall using nut and washer provided. Ensure gasket is centered on faucet prior to tightening. Do not overtighten the nut or reposition the faucet once installed, otherwise damage to the gasket may result. Cutting or trimming of the gasket is not recommended. If the gasket is trimmed or modified, then clear silicone sealant should be used between the faucet and sink/wall surface to prevent water leakage.

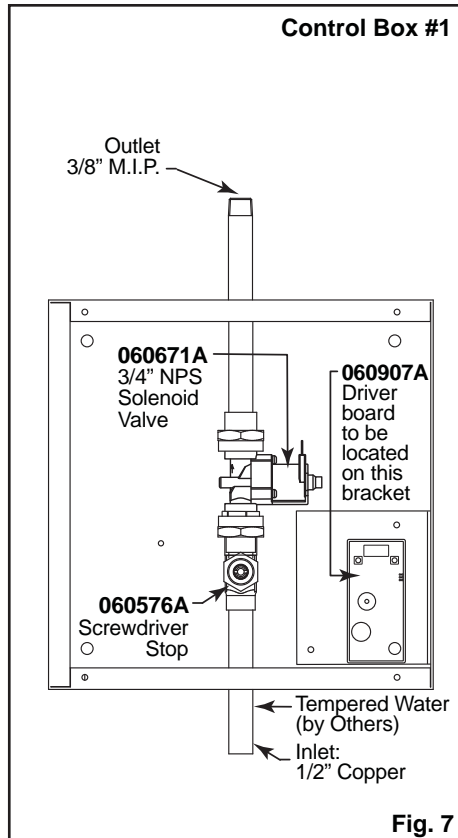

Fig. 7

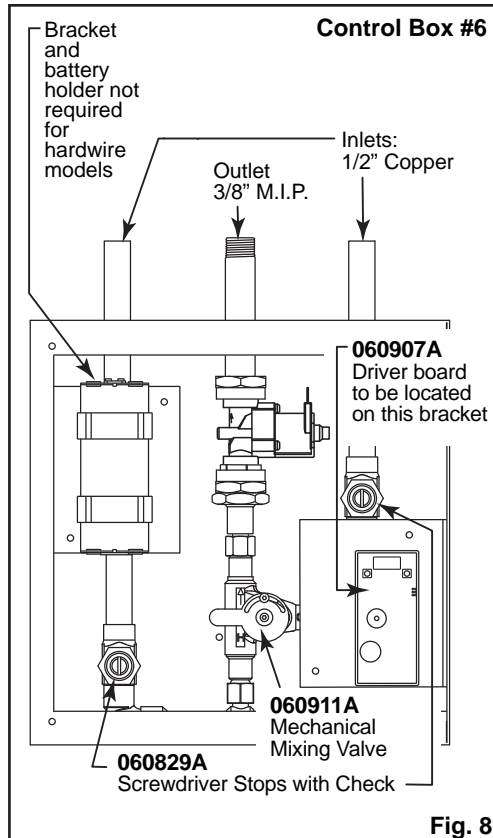

Fig. 8

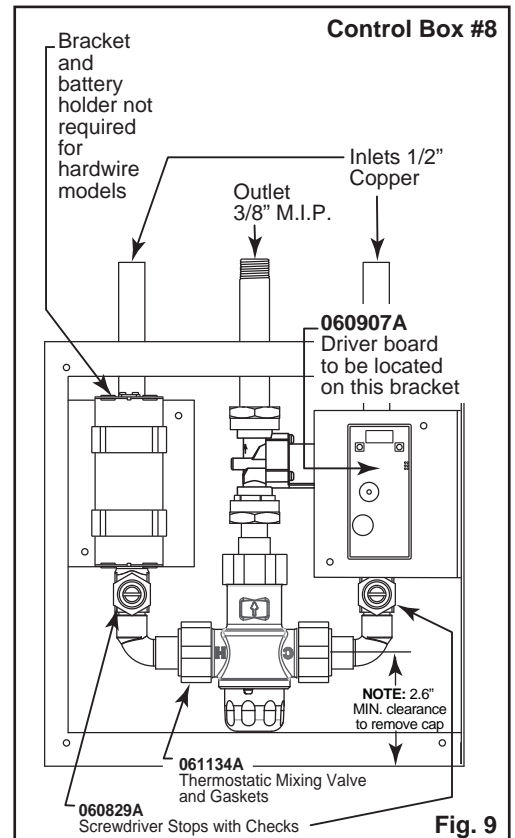

Fig. 9

See Fig. 12 for #7 smooth end spout flow control installation

COVERS

060577A
12" Stainless Steel Cover

060073A
Screws (4/pkg) and driver bit for covers

TMV Repair Kits

061135A
Gasket Kit only (3 pcs)

061137A
Adjustment Wrench

INSTALLATION AND SET UP INSTRUCTIONS

FOR RECESS MOUNT HOUSING:
CONTROL BOXES #1, 6, 8.

STEP 3. CONNECT WATER SUPPLY

Install sink and connect drainage to rough in. See applicable Fig. 7, Fig. 8 or Fig. 9. Please note that the connection tube and fittings are supplied by the installer to connect the 3/8" MIP at the box outlet and compression joint for 3/8" O.D. Soft copper tube at the spout. Connect water supply through to spout. Assure supply lines are completely flushed and free of debris.

STEP 4. FLUSH SYSTEM/SET TEMPERATURE

Remove coverplate from control box. Open screwdriver stop(s) to flush installation for **1 minute minimum**.

- 4A** Run water for a sufficient time so the hot and cold water supplies are as hot and cold as they will get.
- 4B** Place a thermometer in a plastic container and hold in the water stream. Record the temperature reading and note position of temperature control, and lock at the desired setting.
- 4C** If **Mechanical Mixing Valve** (060911A) (Fig. 8). Adjust setting to the desired temperature and lock in place by tightening the vandal resistant screw.

If **Thermostatic Mixing Valve** (Fig. 9). To adjust the mixed outlet temperature of the valve, remove the cap to gain access to the adjusting spindle. The spindle should be rotated towards the "C" side to reduce the temperature and towards the "H" side to increase the temperature - until the desired set point is reached (refer to Fig. 11).

Periodic Inspection/Maintenance - We recommend that this valve is checked at least once per year to ensure its continued function. For installations with poor or unknown water quality, or other adverse supply conditions, it may be necessary to check the valve at more frequent intervals. The temperature should be checked at the same outlet as was used for commissioning in the first instance. If the temperature is more than 3°F from the commissioning in temperature, refer to the included Cash Acme Maintenance and Installation Guide.

- 4D** Close stops.

STEP 5. CONNECT ELECTRICAL SUPPLY, SOLENOID VALVE AND SENSOR

Remove plastic threaded spacer nipple and install solenoid valve with body arrow in the direction of water flow. Install flow control for #7 smooth end spouts. See Fig. 12. Feed sensor wire from spout into control box and then into the battery holder. Connect red solenoid cord to "+" marked solenoid terminal on solenoid valve, black solenoid cord to other solenoid terminal.

⚠ BATTERY VERSION Remove cover from control box and install four "C" batteries provided into the battery holder. After the batteries are installed, make the sensor connection on the driver board. Connect battery clip to battery pack. Ensure snap does not touch any conductive metal surface. One beep should occur to indicate power is applied. Two beeps indicate product is ready for use. Use caution not to damage wires or components on electronic driver board. Secure cover using screws.

⚠ HARDWARE VERSION Install CSA and/or UL approved Class 2 transformer or equivalent in a convenient location or in a pipe chase. **(Do NOT install the transformer inside the control box.)**

With the power off, bring the 24 VAC supply wires to the box. Connect the 24 VAC supply to the 060683A conversion kit. Connect the battery snap of the hardware converter to the driver board battery clip. Ensure snap does not touch any conductive metal surface. Turn on power supply for the transformer and then make the sensor connection on the driver board neatly inside the box. Secure cover using screws.

STEP 6. SERVICES

Open screwdriver stop(s). Flush line. Install aerator, if applicable.

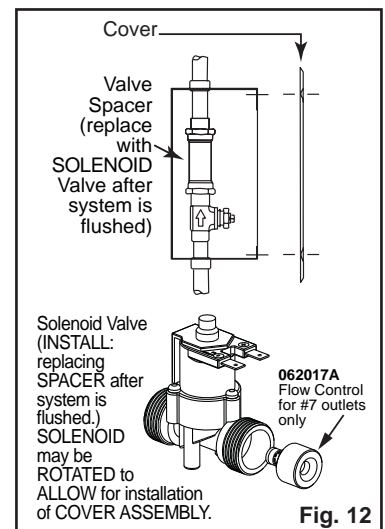
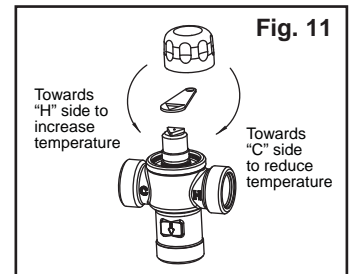
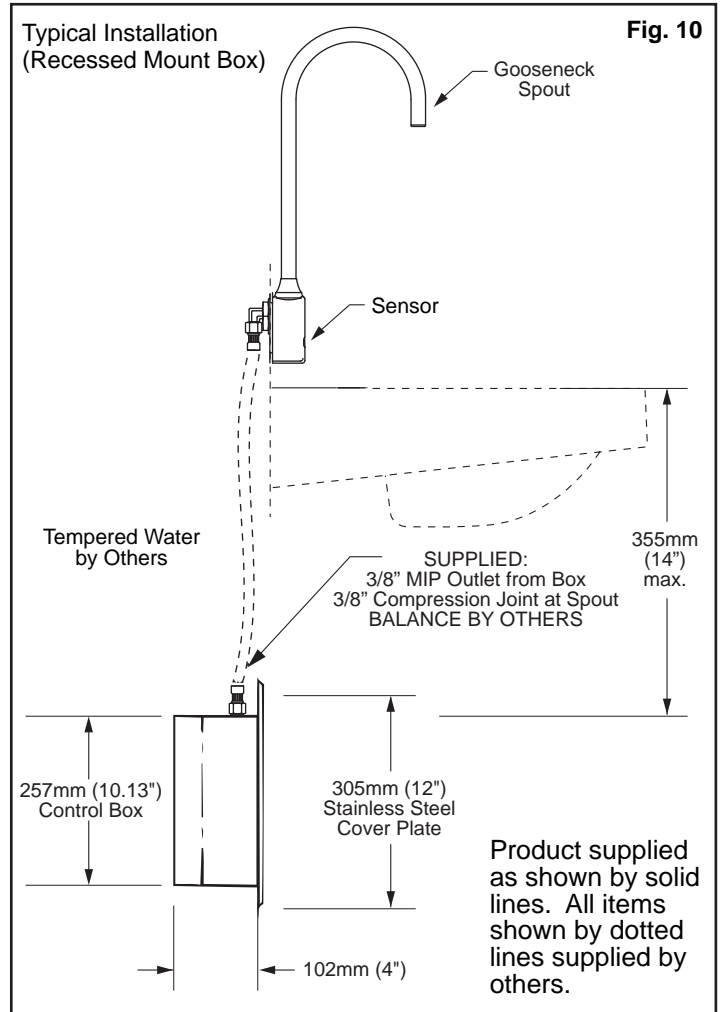

INSTALLATION AND SET UP INSTRUCTIONS

FOR RECESS MOUNT HOUSING: CONTROL BOXES #1, 6, 8.

STEP 7. TEST FOR OPERATION

Test for operation. If unit does not work properly, see Troubleshooting Guide on page 6.

STEP 8. MAKING ADJUSTMENTS

(If adjustments are required. Note factory defaults for program shown in Quick Reference Chart.) Otherwise, replace the driver board housing cover as the electronic product is ready for use.

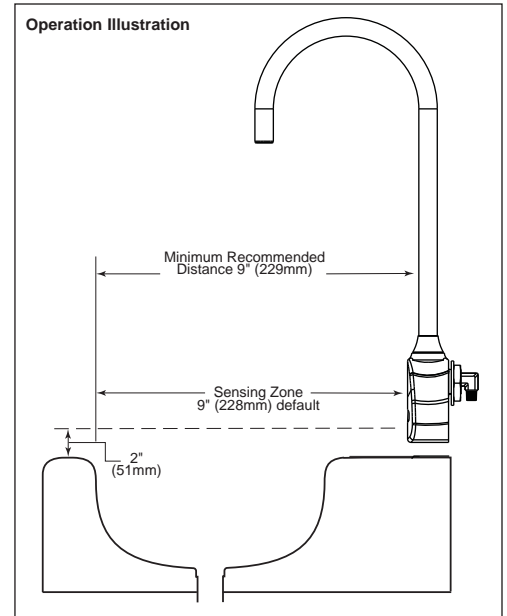

DRIVER BOARD QUICK REFERENCE CHART

Selection Adjustment	Description	Factory Default Setting	Adjustment Range
Sensor Range	You can set the distance at which the sensor will detect hands in the wash area.	9" from sensor	3" to 15" from sensor
Auto Timer (faucet shut-off)	A safety mode in the event the sensor continually sees a target.	45 seconds	15, 30, 45, 60 and 75 seconds

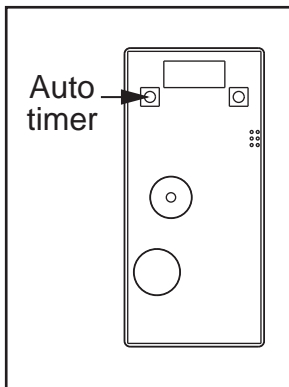

AUTO TIMER (FAUCET SHUT-OFF)

Auto Timer is a safety mode in the event the sensor continually sees a target (ie. tape on the sensor). In this case the faucet will stop after the pre-determined time period expires. The Auto Timer values are 15, 30, 45, 60 and 75 seconds. The Auto Timer default value is 45 seconds.

To adjust the Auto Timer feature, press and release the yellow pushbutton on the left hand side of the digital light display. The current Auto Timer setting will then appear on the light display. Press and release the same pushbutton continuously to scan through the variable time periods (which are displayed as seconds on the digital light display). To return to operation mode, do nothing for 5 seconds.

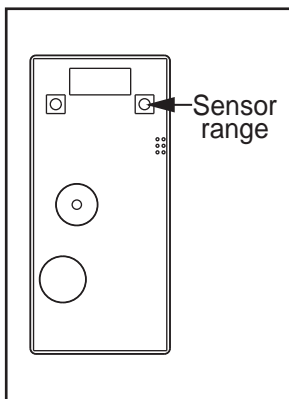

SENSOR RANGE (3-15")

The sensor range is the maximum distance at which the user is detected. The sensor range includes 3", 6", 9", 12" and 15". The sensor range default value is 9". Note: Sensor ranges ± 1 " subject to environmental conditions.

To adjust the sensor range value, press and release the yellow pushbutton on the right hand side of the digital light display. The current Sensor Range setting will then appear on the light display. Press and release the same pushbutton continuously to scan through the variable sensor ranges (which are displayed as inches on the digital light display). To return to operation mode, do nothing for 5 seconds.

If you have any questions about the installation of this product or need help troubleshooting this product, please call Delta Commercial Technical Services at **1-800-387-8277**.

CARE INSTRUCTIONS

This Delta Commercial faucet is designed and engineered in accordance with the highest quality and performance standards. With proper care, it will give years of trouble free service. Care should be given to the cleaning of this product. Although the chrome finish is extremely durable, it can be DAMAGED by ACIDIC CLEANERS (i.e., cleaners designed specifically for vitreous china lavatories and water closets), HARSH ABRASIVES or POLISH. To clean, simply wipe the surface with a damp cloth and blot dry with a soft cloth. Avoid directing water spray or cleaners directly at sensor lens.

TROUBLE SHOOTING GUIDE

If the faucet does not work properly, follow the steps below in order.

Step 1	Check to ensure faucet was installed according to the M&I sheet.	Note: See attached M&I, Pages 1 to 5.	
	Test for operation. If unit does not operate: If faucet shuts off due to interference:	Check lens to be sure it is not blocked with foreign matter. Remove vinyl scratch protector from sensor, if present. Check to be sure power cable is properly secured in fitting. Check to be sure batteries are fresh and properly installed. Check two wires to solenoid to be sure they are connected correctly. Check to be sure water supply is turned on. When the faucet detects an object for longer than 45 seconds, it will automatically shut off until the object is removed. Once the object is removed for at least 1 second, the faucet will operate normally.	
Step 2	Faucet makes a beeping noise.	BATTERY POWERED Faucet beeps twice when turning off: indicates batteries are low and need to be replaced (1500 cycles or 2 weeks left).	Replace batteries.
		Faucet beeps continuously when hands in front of spout and no water. Faucet locked out because batteries are too low.	Replace batteries.
Step 3	The faucet stops working. No water flow. Check the function of the solenoid.	HARDWIRE Check voltage from converter and transformer. It should be approximately 6.4 volts DC coming from converter to driver board.	Replace hardwire converter 060683A, if required.
		The solenoid should "click" when activated.	
		If there is a clicking sound;	This indicates that both the sensor and the solenoid are functioning. Ensure inlet screen on solenoid is not plugged with debris. Clean as required.
		If no clicking sound;	Check the incoming water supply. Turned on, proper pressure and volume, etc. Correct as required.
Step 4	If faucet does not activate or works erratically;	Check for a pressure lock between the mixing valve and the solenoid. Turn off the water supply and undo the connection to the inlet of the solenoid, this will eliminate any built up pressure. Then activate sensor and test fire the solenoid.	
		If after completion of above, there is no clicking sound; Defective solenoid.	Replace 060910A or 060671A solenoid.
Step 5	If after completion of all above steps, the valve still does not function correctly; call Technical Service for further assistance at 1-800-387-8277.	Check for electrical interference. Check for interference from other electrical devices within close proximity to the spout or battery box. Devices such as other infrared devices, transformers, etc.	Call Technical Service if any such conditions are found, 1-800-387-8277.

Note: Periodic cleaning of solenoid screens, aerator screens and flow controls is recommended.

Delta Commercial Faucet Limited Warranty

All parts of the Delta® HDF® and TECK® faucets are warranted to the original consumer purchaser to be free from defects in material, finish and workmanship for a period of five (5) years unless otherwise specifically stated in the catalogue and price book. This warranty is made to the original consumer purchaser and shall be effective from date of purchase as shown on purchaser's receipt.

Delta will, at its option, repair or replace, FREE OF CHARGE, during the warranty period, any part which proves defective in material or workmanship under normal installation, use and water and service conditions. If Delta Faucet concludes that the returned part was manufactured by Delta Faucet and is, in fact, defective, then Delta Faucet will honour the warranty stated herein. Replacement parts can be obtained from your local dealer or distributor listed in the telephone directory or by returning the part along with the purchaser's receipt to our factory, TRANSPORTATION CHARGES PREPAID, at the address listed. THIS WARRANTY IS THE ONLY EXPRESS WARRANTY MADE BY DELTA. ANY CLAIMS MADE UNDER THIS WARRANTY MUST BE MADE DURING THE FIVE YEAR PERIOD REFERRED TO ABOVE. ANY IMPLIED WARRANTIES, INCLUDING THE IMPLIED WARRANTY OF MERCHANTABILITY OF FITNESS FOR A PARTICULAR PURPOSE, ARE LIMITED IN DURATION TO THE DURATION OF THIS WARRANTY. LABOUR CHARGES AND/OR DAMAGE INCURRED IN INSTALLATION, REPAIR OR REPLACEMENT AS WELL AS INCIDENTAL AND CONSEQUENTIAL, SPECIAL, INDIRECT OR PUNITIVE DAMAGES CONNECTED THEREWITH ARE EXCLUDED AND WILL NOT BE PAID BY DELTA FAUCET.

Some states do not allow limitations on how long an implied warranty lasts, or the exclusion or limitation of incidental or consequential damages, so the above limitations or exclusions may not apply to you. This warranty gives you specific legal rights, and you may also have other rights which vary from state to state.

This warranty is for commercial products only from Delta Faucet Company and Delta Faucet Canada (a division of Masco Canada Limited) and is void for any damage to this faucet due to misuse, abuse, neglect, accident, improper installation, any use in violation of instructions furnished by Delta Faucet or any use of replacement parts other than genuine Delta parts.

Garantie Limitée Delta Commercial

Toutes les pièces des robinets de marque Delta® HDF® et TECK® sont garanties contre tout défaut de matériel, de finition et de main-d'oeuvre pour une période de cinq (5) ans, sauf indication contraire stipulée dans le catalogue et la liste des prix. Cette garantie est offerte à l'acheteur original et entre en vigueur à compter de la date d'achat indiquée sur la preuve d'achat.

Delta procédera, à son entière discrétion, à la réparation ou au remplacement, SANS FRAIS, durant la période de garantie, de toute pièce qui présente un défaut de matériel ou de main-d'oeuvre dans des conditions d'installation, d'usure, d'eau et de service normales. Si Delta Faucet détermine que la pièce retournée a été fabriquée par Delta Faucet et qu'en effet, cette pièce défectueuse, Delta Faucet respectera alors la garantie mentionnée ci-dessous. Les pièces de rechange peuvent être obtenues chez votre marchand local ou le distributeur inscrit dans votre annuaire téléphonique, ou en retournant la pièce ainsi que la preuve d'achat à notre usine, FRAIS DE TRANSPORT PRÉPAYÉS, à l'adresse indiquée. CETTE GARANTIE EST LA SEULE GARANTIE EXPRESSE FAITE PAR DELTA.

TOUTE RÉCLAMATION FAITE EN VERTU DE CETTE GARANTIE DOIT ÊTRE PRÉSENTÉE DURANT LA PÉRIODE DE CINQ ANS MENTIONNÉE CI-DESSUS. TOUTE GARANTIE IMPLICITE, Y COMPRIS LA GARANTIE IMPLICITE DE VALEUR COMMERCIALE D'ADÉQUATION POUR UN USAGE PARTICULIER, EST LIMITÉE DANS LE TEMPS À LA DURÉE DE LA PRÉSENTE GARANTIE.

LES FRAIS DE MAIN-D'OEUVRE ET/OU LES DOMMAGES ENCOURUS DURANT L'INSTALLATION, LA RÉPARATION OU LE REMPLACEMENT AINSI QUE LES DOMMAGES ACCIDENTELS ET CONSÉCUTIFS, SPÉCIAUX, INDIRECTS OU PUNITIFS QUI SONT RELIÉS SONT EXCLUS ET NE SERONT PAS PAYÉS PAR DELTA FAUCET.

Certains états ne permettent pas la limitation de la durée de la garantie implicite, ou l'exclusion ou la limitation des dommages accidentels ou consécutifs, et par conséquent, les limitations ou les exclusions stipulées ci-dessus peuvent ne pas s'appliquer dans votre cas. Cette garantie vous accorde certains droits reconnus par la loi et vous pouvez aussi avoir d'autres droits qui varient d'un état à l'autre.

Cette garantie s'applique seulement aux produits commerciaux de Delta Faucet Company et Delta Faucet Canada (une filiale de Masco Canada Limited) et est nulle de plein droit pour tout dommage causé à ce robinet en raison d'une mauvaise utilisation, d'abus, de négligence, d'accident, de mauvaise installation, pour tout usage en contravention des directives fournies par Delta Faucet ou pour tout usage de pièces de rechange autres que des pièces originales Delta.

Garantía Limitada de las Llaves de Agua Comerciales Delta

Todas las piezas de las llaves de agua (grifos) Delta® HDF®, TECK® están garantizadas al comprador consumidor original de estar libres de defectos de material, acabado y fabricación por un periodo de cinco (5) años a menos que sea establecido específicamente de otra manera en el catálogo o libro de precios. Esta garantía se le otorga al comprador consumidor original y será efectiva desde la fecha de compra indicada en el recibo del comprador.

Delta, a su opción, reparará o reemplazará, GRATUITAMENTE, durante el periodo de garantía, cualquier pieza que resulte defectuosa en material o fabricación bajo instalación, uso, agua y condiciones de servicio normales. Si Delta Faucet concluye que la pieza devuelta fue fabricada por Delta Faucet y es, de hecho, defectuosa, entonces Delta Faucet honrará la garantía establecida en este documento.

Las piezas de reemplazo se pueden obtener de su tienda o distribuidor local listado en la guía telefónica o devolviendo la pieza junto con el recibo de compra a nuestra fábrica, CON LOS GASTOS DE ENVÍO PRE-PAGADOS, a la dirección indicada. ESTA GARANTÍA ES LA ÚNICA GARANTÍA EXPRESA HECHA POR DELTA. CUALQUIER RECLAMO HECHO BAJO ESTA GARANTÍA DEBE SER HECHO DURANTE EL PERÍODO DE CINCO AÑOS ARRIBA MENCIONADO. CUALQUIER GARANTÍA IMPLÍCITA, INCLUYENDO LA GARANTÍA IMPLÍCITA DE COMERCIABILIDAD DE EMPLEO PARA UN PROPÓSITO PARTICULAR, TIENE UNA DURACIÓN LIMITADA A LA DURACIÓN DE ESTA GARANTÍA. LOS CARGOS DE MANO DE OBRA Y/O DAÑO INCURRIDO DURANTE LA INSTALACIÓN, REPARACIÓN O REEMPLAZO, COMO TAMBIÉN DAÑOS INCIDENTALES O RESULTANTES, ESPECIALES, INDIRECTOS O PUNITIVOS RELACIONADOS CON LO MENCIONADO, QUEDAN EXCLUIDOS Y NO SERÁN CUBIERTOS POR DELTA FAUCET.

Algunos estados no permiten limitaciones de la duración de una garantía implícita, o la exclusión o limitación de daños incidentales o consecuentes, de manera que las limitaciones o exclusiones arriba mencionadas puedan no aplicarse en su caso. Esta garantía le otorga derechos legales específicos, y usted también puede tener otros derechos que varían de estado a estado.

Esta garantía es solo para productos comerciales de Delta Faucet Company y Delta Faucet Canada (una división de Masco Canada Limited), y queda anulada por cualquier daño ocasionado a esta llave de agua resultante del mal uso, abuso, descuido, accidente, instalación incorrecta, cualquier uso en violación de las instrucciones proporcionadas por Delta Faucet o el uso de cualquier parte de repuesto que no sea una parte genuina de Delta.

Delta Faucet Canada, a division of Masco Canada Limited
350 South Edgeware Road, St. Thomas, Ontario, N5P 4L1
1-800-567-3300 (English) 1-800-265-9245 (French)

Delta Faucet Company
Box 40980, 55 East 111th St., Indianapolis, IN, U.S.A. 46280
(317) 848-1812

For further technical assistance, call Delta Commercial Technical Service at 1-800-387-8277.
Pour obtenir de l'assistance technique, appelez le Service Technique de Delta Commercial au 1-800-387-8277.
Por la asistencia técnica adicional, llame al servicio técnico de Delta Comercial al 1-800-387-8277.