



PRODUCT DESCRIPTION

PRODUCT MEASUREMENTS

- Width: 24 inches (60.96 cm)
- Depth: 22 inches (55.88 cm)
- Height: 28.5 inches (72.39 cm)

RECOMMENDED ACCESSORIES

- Any DECOLAV® Stone or Glass Vessel
- DECOLAV® 9020 Mounting Ring
- DECOLAV® 9298 Push Button Closing Umbrella Drain
- DECOLAV® 9100 Decorative Bottle Trap

ROUGHING-IN DIMENSIONS

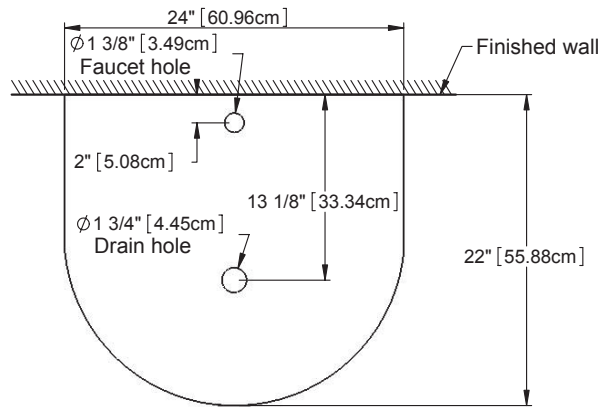

TOP VIEW

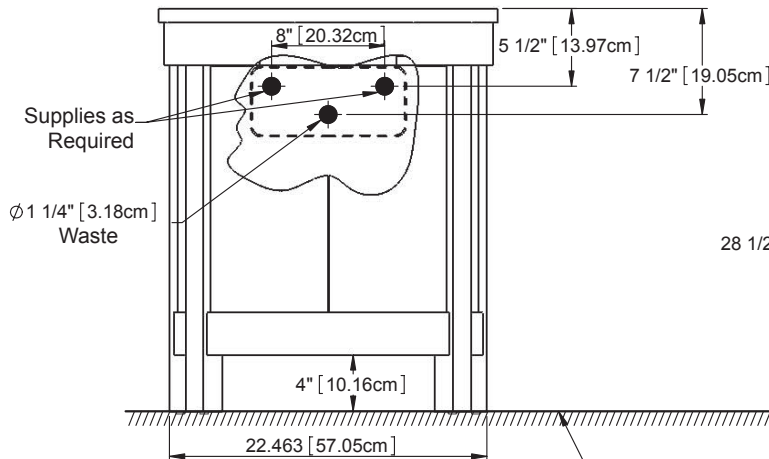

FRONT VIEW

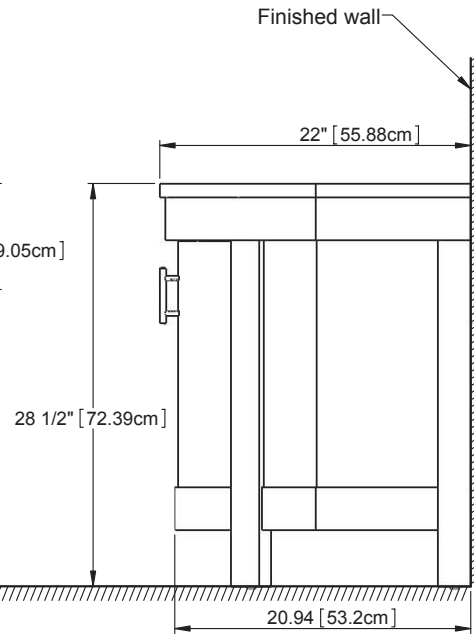

SIDE VIEW