



SPECIFICATIONS
ESSEV30
 ENERGY STAR® POWER PACK

HVI 2100 CERTIFIED High Speed 300 CFM/4.5 Sones @ 0.10" SP.
 Medium Speed 200 CFM/2.0 Sones @ 0.10" SP.
 Low Speed 140 CFM/0.7 Sones @ 0.10" SP., 49.8 Watts

• **Dimensions**

Overall bottom projection - 11"
 Height - 11"
 Width - 31¼" (for 36" or larger canopy)

• **Body**

Galvanized steel body with stainless steel fascia. Install at least 24" above the cooking surface.

• **Lighting**

Electronic Quick Start Ballast – Uses two 18 Watt triple tube (4-pin base) CFL bulbs (included).

• **Ducting**

Vertical ducting: 6" round ducting with all metal outlet adapter and back draft damper

• **Filters**

Dishwasher safe, aluminum mesh grease filters (included).

• **Blower**

3 speed, permanently split capacitor motor. Rated 120 volts, 60 hz. with a dual inlet, electronically balanced polymeric centrifugal blower wheel

Barcelona®
 Collection

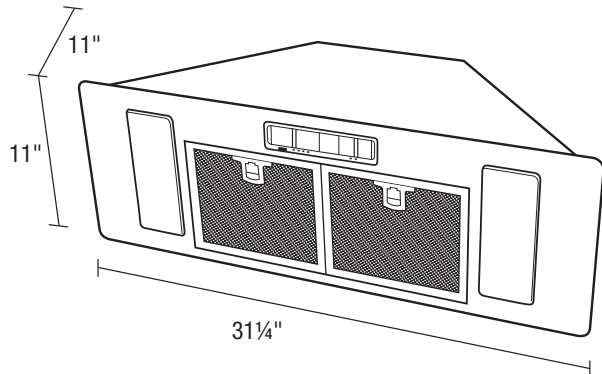

EXPANDED PERFORMANCE

Air Flow - CFM	Static Pressure (inches of w.g.)						Sones @ .1 SP	Fan Speed RPM	Power Watts	Amps
	0	0.1	0.15	0.25	0.3	0.375				
High Speed	315	300	292	271	259	238	4.5	1490	89.9	
Medium Speed	207	200	196	185	178	163	2.0	1335	67.6	
Low Speed	148	140	134	119	109	92	0.7	1080	49.8	

PROJECT							ARCHITECT			
LOCATION							ENGINEER			
CONTRACTOR							SUBMITTED BY			DATE
FAN NUMBER	MODEL NUMBER	CFM	IN W.C.	RPM	WATTS	AMPS	SONES	QTY	OPTIONAL EQUIPMENT & REMARKS	



U.S.: 820 Lincoln Avenue
 West Chester, Pennsylvania 19380-4466
 Tel: (610) 692-7400 • 877-304-3785
 Fax: (610) 696-8048

Canada: 8 Edvac Drive
 Brampton, Ontario L6S 5P2
 Tel: (905) 456-2033 • 800-250-8767
 Fax: (905) 456-1015