



T10 Pro Smart Thermostat with RedLINK

PRODUCT DATA

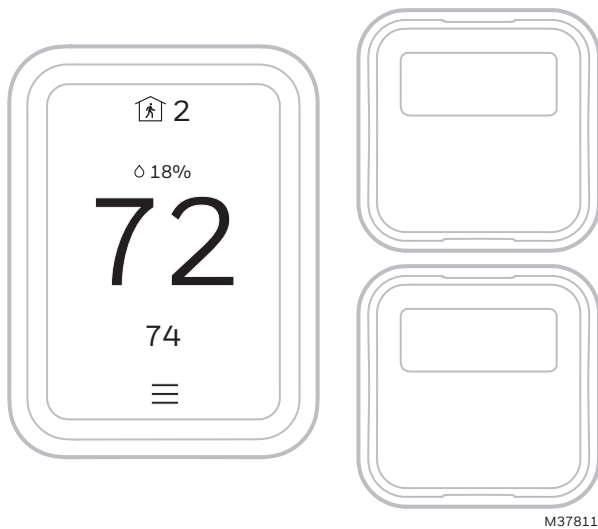

Fig. 1.

APPLICATION

The T10 Smart thermostat with RedLINK™ features an effortless, 7-Day programmable touchscreen thermostat. Compatible with 24 VAC systems including:

- Up to 3 Heat/2 Cool heat pump systems
- Up to 2 Heat/2 Cool conventional
- Dual Fuel systems
- Radiant hot water systems including hot water fan coil
- Humidification, dehumidification, or ventilation.

FEATURES

- RedLINK™ C7189R2002 Wiresss Indoor Sensor Compatible (Up to 20 sensors per thermostat).

- Increase your content and profit per job by including RedLINK™ indoor temperature, humidity, and motion sensors that meet your customers' comfort and convenience needs. they can be used in combination for temperature averaging or individually. These sensors also sense motion and you can select priority zones based on where motion is detected or by scheduling.
- Flexible scheduling: You can choose to use location based temperature control (geofence technology), program a set schedule or use a combination of both to make sure your home is always comfortable.
- Location-based temperature control: Using geofence technology, the T10 Smart thermostat with RedLINK will automatically use your smartphone's location, which can save energy when you leave and make your home comfortable by the time you return. See "Scheduling and Geofencing" on page 29 for more.
- Smart scheduling: Adds a Sleep period to location-based temperature control. See "Scheduling and Geofencing" on page 29 for more.
- Time-based scheduling: You can program a schedule where every day is different, a schedule where weekdays and weekends are different or a schedule where every day is the same. There are four adjustable periods per day: Wake, Away, Home and Sleep. See "Scheduling and Geofencing" on page 29 for more.
- No schedule: You can also choose not to set a schedule and adjust the thermostat manually. See page 30.
- Tip: The Honeywell Home app can be used to manage multiple thermostats and multiple users in a household.
- Smart Alerts: The T10 Smart thermostat with RedLINK™ will send alerts for things like extreme indoor temperatures and reminders for things like filter changes.
- Auto change from heat to cool: When Auto mode is selected, the T10 Smart thermostat with RedLINK™ can automatically determine whether your home needs heating or cooling to reach the desired temperature.
- Adaptive Intelligent Recovery: The T10 Smart thermostat with RedLINK™ learns your heating and cooling cycle times to make sure the system delivers the temperature you want, when you want it.



CONTENTS

Application	1
Specifications	3
Dimensions.....	3-5
Regulatory information	5
Installation	
Mounting.....	6
Wiring.....	6-13
Installing wireless indoor sensors	13-14
Installing Wired Indoor Sensor	14-15
Installing Wired outdoor sensor	15-16
Installer setup.....	16-28
Wi-Fi	
Wi-Fi setup	28-29
Wi-Fi setup, after initial installation	29
Scheduling and Geofencing	29-30
Main Menu Options	30
Installer Options	30-31
Getting the most from the T10 Smart Thermostat	31
Setting the Time/Date	31-32
Setting the Fan	32
Setting the System mode	32
Using Priority	32
Alerts and notifications	32-33
Setting Preferences	
Fahrenheit/Celsius	33
Language	33
Inactive backlight settings	33
Display offsets.....	33
Adaptive Intelligent Recovery.....	33
Date and Time.....	33
Reminders	33
Clean screen.....	33
Indoor Air Quality (IAQ control)	
Humidification	34
Dehumidification	34-35
Ventilation.....	35-36
Operation	
Cleaning the screen	36
Security settings.....	37
Dealer information.....	37
Auto changeover.....	37
Auxiliary heat	37
Emergency heat.....	37
Adaptive Intelligent Recovery	37
Compressor Protection	38
P + I Control	38
Heat Differential	38
Droop.....	38-39
Upstage Timer	38
Programmed Recovery.....	39
Finish with high heat/cool stage	39
Heat pump and backup heat operation	40
Batteries	40
Troubleshooting.....	41

SPECIFICATIONS

Table 1. Thermostat Description

Feature	Description
Powering Method	Common wire required
Stages:	Equipment type:
<ul style="list-style-type: none"> Up to 3H/2C Heat pump Up to 2H/2C conventional 	<ul style="list-style-type: none"> Dual fuel Hot water, steam, or hot water coil Gas or oil furnace High-efficiency or mid-efficiency Cool only Does not work on Milivolt systems Humidifier, Dehumidifier, or Ventilator control
Changeover	Manual or Auto Changeover Selectable
System Setting	Em Heat-Heat-Off-Cool-Auto
Fan Setting	Auto-On-Circ-Follow Schedule

Table 2. Electrical Ratings

Terminal	Voltage (50/60Hz)	Running Current
W (Heat)	20-30 VAC	0.02-1.0 A
W2 (Aux) Heat	20-30 VAC	0.02-1.0 A
E (Emergency Heat)	20-30 VAC	0.02-0.5 A
Y (Compressor Stage 1)	20-30 VAC	0.02-1.0 A
Y2 (Compressor Stage 2)	20-30 VAC	0.02-1.0 A
G (Fan)	20-30 VAC	0.02-0.5 A
O/B (Changeover)	20-30 VAC	0.02-0.5 A
L/A (Heat Pump Fault)	20-30 VAC	0.02-0.5 A
U (Hum, Dehum, or Vent)	20-30 VAC	0.02-0.5 A

Does not work on Milivolt systems
 Power Consumption: 3VA

RedLINK Communication:
 Frequency: 900 Mhz frequency range
 Re-Sync Time: RedLINK devices re-establish communication within 6 minutes after AC power resumes.

Temperature Setting Range:
 Heating: 40 to 90 °F (4.5 to 32 °C).
 Cooling: 50 to 99 °F (10 to 37 °C).
 Note: Adjustable high and low range-stop settings.

Temperature Sensor Accuracy:
 ± 1.5 F at 70 F (0.75 C at 21.0 C)

Humidification Setting Range:
 10% to 60% RH.

Dehumidification Setting Range:
 40% to 80% RH.

Humidity Display Range:
 0% to 99%.

Humidity Sensor Accuracy:
 ± 5% RH from 30% to 50% RH at 75 F.

Cool Indication:
 Display floods blue and says "cooling to" when cool is on.

Heat or Em Heat Indication:
 Display floods orange and says "heating to" when heat is on.

AUX Heat Indication:
 Display shows "Aux heat on" above the room temperature.

Interstage Differential:
 Comfort:
 The thermostat keeps the indoor temperature within 1 degree of the setpoint (droop less control). Unless the system is dual fuel, or a droop setting is used, the thermostat turns on stage 2 when the capacity on stage 1 reaches 90%.

Clock Accuracy:
 1 minute per month at 77 °F (25 °C). ± 2 minutes per month over the operating ambient temperature range. Automatically updates when connected to Wi-Fi router and registered to account.

Mounting Means:
 Thermostat mounts directly on the wall in the living space using mounting screws and anchors provided. Can mount to a horizontal 2 x 4 in. junction box using J-Box adaptor (included).

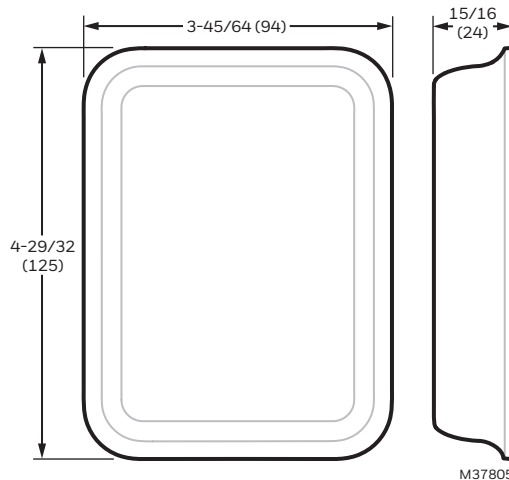

Fig. 2. Dimensions of thermostat in In. (mm).

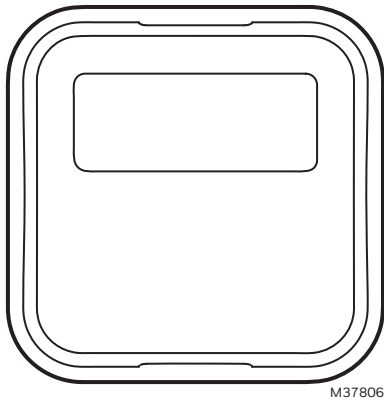

Fig. 3. Dimensions of C7189R2002 wireless indoor sensor in in. (mm).

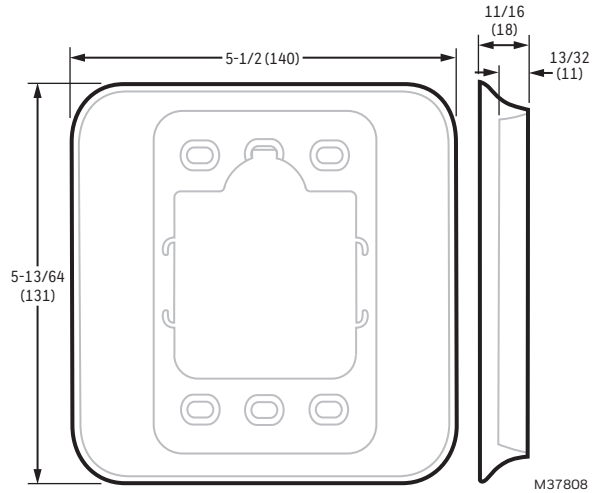

Fig. 5. Dimensions of cover plate in in. (mm)

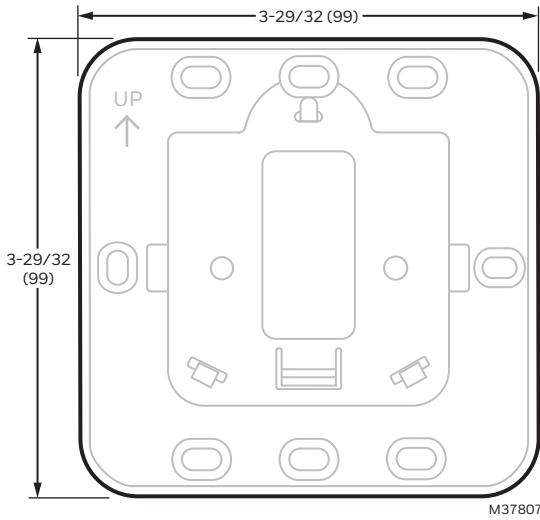

Fig. 4. Dimensions of J-Box Adaptor in in. (mm).

Table 3. RedLINK T10 Thermostat and RedLINK Wireless Accessories

Product	Part Number	Operating Ambient Temperature	Operating Relative Humidity	Shipping Temperature	Physical Dimensions in in. (mm)	Color
Thermostat	THX321WF2001W	37 °F to 102 °F. (2.8 °C to 38.9 °C).	5% to 90% Non-Condensing	-20 to 120 °F (-28.9 to 48.9 °C)	4.9 H x 3.7 W x 0.93 D (125.4 x 94.1 x 23.68)	White
Wireless indoor temperature, humidity, and motion sensor (up to 20 per thermostat)	C7189R2002	* 0 to 120 °F (-17.8 to 48.9 °C)	5% to 90% Non-Condensing	-20 to 120 °F (-28.9 to 48.9 °C)	2-7/8 x 1-7/8 x 15/16 (74 x 48 x 24)	White
Other RedLINK Accessories	At the time of Product Launch, the C7189R2002 indoor sensors are the only RedLINK wireless accessories compatible with the T10 thermostat. RedLINK accessories used with Prestige, RedLINK VisionPRO models and RedLINK FocusPRO models can not be used with the T10.					

* For optimal Battery Life, operating temperature range of 35 to 114 °F (1.7 to 45.6 °C) is recommended.

Table 4. Other Accessories for Use with the T10 Thermostat

Product	Part Number	Operating Ambient Temperature	Operating Relative Humidity	Shipping Temperature	Physical Dimensions in in. (mm)	Color
Wired Outdoor Sensor (10K ohm Negative Temperature Coefficient)	C7089U1006	-40 to 120 °F (-40 to 48.9 °C)	5% to 95% Non-Condensing	-40 to 130 °F (-40 to 54.4 °C)	1-1/2 (38)	Black
Wired Wall Mount Indoor Sensor (10K ohm Negative Temperature Coefficient)	C7189U1005	45 to 88 °F (7 to 32 °C)	5% to 95% Non-Condensing	-20 to 120 °F (-28.9 to 48.9 °C)	2-9/32 x 1-1/2 x 11/16 (58 x 38 x 18)	Premier White
Coverplate (covers marks left by old thermostats)	Included with thermostat	--	--	--	5-11/64" X 5-1/2" X 11/16" (131.4mm x 139.7mm x 17.5mm)	White
C-wire adaptor	THP9045A1098	-40 to 163 °F (-40 to 73 °C)	5% to 90% Non-Condensing	-40 to 185 °F (-40 to 85 °C)	--	Gray

Regulatory information

FCC REGULATIONS

47 CFR § 15.19 (a)(3)

This device complies with part 15 of the FCC Rules.

Operation is subject to the following two conditions:

1. This device may not cause harmful interference, and
2. This device must accept any interference received, including interference that may cause undesired operation.

47 CFR § 15.21 (USA only)

Changes or modifications not expressly approved by the party responsible for compliance could void the user's authority to operate the equipment.

47 CFR § 15.105 (b)

See <https://customer.resideo.com/en-US/support/residential/codes-and-standards/FCC15105/Pages/default.aspx> for additional FCC information for this product.

IC REGULATIONS RSS-GENThis device complies with Industry Canada's license-exempt RSSs. Operation is subject to the following two conditions:

1. This device may not cause interference; and
2. This device must accept any interference, including interference that may cause undesired operation of the device.

SYSTEM INSTALLATION

When Installing This Product...

1. Read these instructions carefully. Failure to follow the instructions can damage the product or cause a hazardous condition.
2. Check the ratings given in the instructions to make sure the product is suitable for your application.
3. Installer must be a trained, experienced service technician.
4. After completing installation, use these instructions to verify the product operation.

Finding Your Password (Date Code)

You will need the thermostat password to:

- Add or remove RedLINK accessories
- Make changes to Installer Setup
- Perform an Installer Test
- Reset Thermostat to Factory Default Settings

To find the password (date code) Press the menu (three horizontal lines) Scroll down and select "Dealer Information".

CAUTION

Electrical Hazard.

Can cause electrical shock or equipment damage.

Disconnect power before wiring.

Selecting Thermostat Location

Install the thermostat about 5 ft. (1.5m) above the floor in an area with good air circulation at average temperature. See Fig. 6.

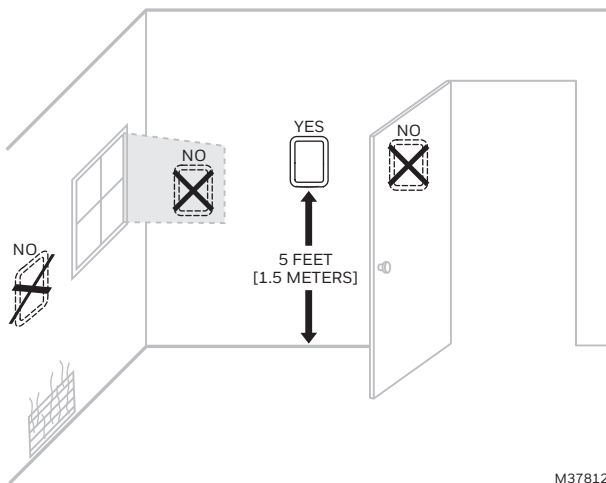

Fig. 6. Selecting thermostat location

Do not install the thermostat where it can be affected by:

- Drafts or dead spots behind doors and in corners
- Hot or cold air from ducts
- Radiant heat from sun or appliances
- Concealed pipes and chimneys

- Unheated (uncooled) areas such as an outside wall behind the thermostat

UWP Mounting System Installation

1. Open package to find the UWP. See Step 1 in Fig. 7.
2. Position the UWP on the wall. Level and mark hole positions. See Step 2 in Fig. 7. Drill holes at marked positions, and then lightly tap supplied wall anchors into wall using a hammer. Drill 7/32" holes for drywall.
3. Pull the door open and insert wires through the wiring hole of the UWP. See Step 3 in Fig. 7.
4. Place the UWP over the wall anchors. Insert and tighten mounting screws supplied with the UWP. Do not over-tighten. Tighten until the UWP no longer moves. Close the door. See Step 4 in Fig. 7. Use 3x supplied screws #8 1-1/2".

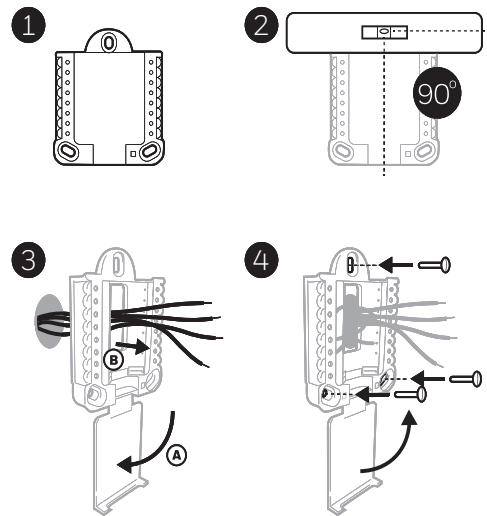

M37786

Fig. 7.

Optional Decorative Cover Plate Installation

Use the Optional Cover Plate when:

- Mounting the thermostat to an electrical junction box
- Or when you need to cover paint gap from the old thermostat.

5. Separate the Junction Box Adapter from the Cover Plate. See Step 5 in Fig. 8.
6. Mount the Junction Box Adapter to the wall or an electrical box using any of the eight screw holes. Insert and tighten mounting screws supplied with Cover Plate Kit. Do not over-tighten. Make sure the Adapter Plate is level. See Step 6 in Fig. 8. Use 2x supplied screws #6 5/8".
7. Attach the UWP by hanging it on the top hook of the Junction Box Adapter and then snapping the bottom of the UWP in place. See Step 7 in Fig. 8.
8. Snap the Cover Plate onto the Junction Box Adapter. See Step 8 in Fig. 8.

Wiring UWP

Push down on the tabs to put the wires into the inner holes of their corresponding terminals on the UWP (one wire per terminal) until they are firmly in place.

Gently tug on the wires to verify they are secure.

If you need to release the wires again, push down the terminal tabs on the sides of the UWP. This wiring is just an example, yours may vary.

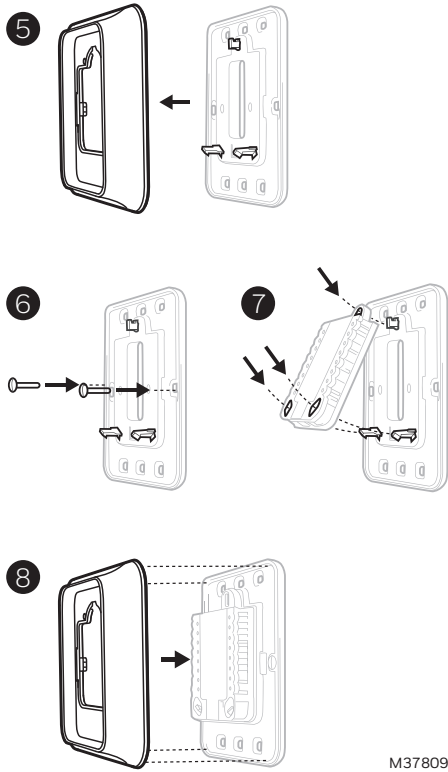
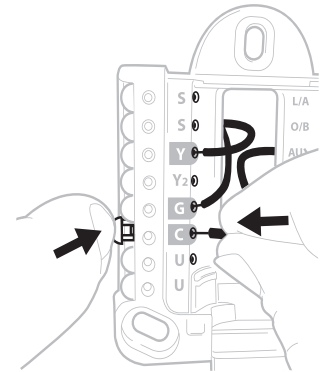

Fig. 8.



M37788

Fig. 9.

Terminal Designations

Conventional Systems		Heat Pump Systems	
Terminal	Description	Terminal	Description
S/S	Input for a wired indoor, outdoor sensor	S/S	Input for a wired indoor, outdoor sensor
Y	Compressor Stage 1	Y	Compressor Stage 1
Y2	Compressor Stage 2	Y2	Compressor Stage 2
G	Fan Relay	G	Fan Relay
C	24VAC Common wire from secondary side of cooling transformer (if 2 transformers)	C	24VAC Common wire from secondary side of cooling transformer
K*	Connect to K on C-wire adaptor	K*	Connect to K on C-wire adaptor
U/U**	Relay for humidifier, dehumidifier, or ventilator	U/U**	Relay for humidifier, dehumidifier, or ventilator
A		L/A	Connect to compressor monitor
W	Heat Stage 1	O/B	Changeover valve for heat pumps
W2	Heat Stage 2	AUX	Backup Heat
		E	Emergency Heat
R	24 VAC Heating transformer	R	24 VAC Heating transformer
Rc	24 VAC Cooling transformer	Rc	24 VAC Cooling transformer

* The THP9045A1098 C-wire adaptor is used on heat/cool systems when you only have four wires at the thermostat and you need a fifth wire for a common wire. Use the K terminal in place of the Y and G terminals on conventional or heat pump systems to provide control of the fan and the compressor through a single wire—the unused wire then becomes your common wire. See THP9045 instructions for more information.

** See note on Wiring U terminals on the following page.

Setting Slider Tabs

Set R Slider Tab, see Fig. 10.

- Use built-in jumper (**R Slider Tab**) to differentiate between one or two transformer systems.
- If there is only one R wire, and it is connected to the **R**, **Rc**, or **RH** terminal on the old thermostat, set the slider to the **up** position (**1 wire**).
- If there is one wire connected to the **R** terminal and one wire connected to the **Rc** terminal, set the slider to the **down** position (**2 wires**).

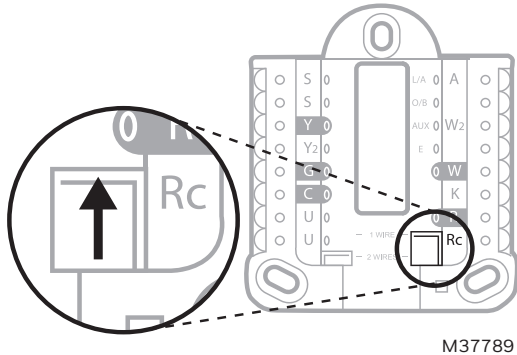

Fig. 10.

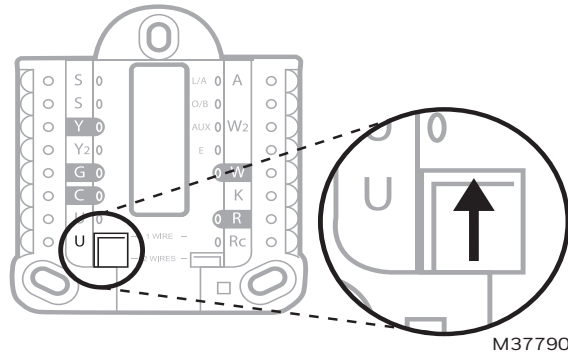

Fig. 11.

WIRING

NOTES:

1. Use 18- to 22- gauge thermostat wire. Shielded cable is not required.
2. Set the R Slider Tab on the UWP to the up position (1 wire) for 1 transformer systems or the down position (2 wires) for 2 transformer systems.
3. Set the U Slider Tab to the position shown for IAQ wiring diagrams on pages 12-13.

Set U Slider Tab, see Fig. 11.

- Use built-in jumper (**U Slider Tab**) for IAQ device.
- When the **U Slider Tab** is in the down position (**2 wires**) the U contacts are a dry set of contacts.
- If your IAQ device is powered by the cooling transformer, move the **U Slider Tab** to the up position (1 wire). When this is done, the lower U terminal is internally jumped to the Rc terminal. In this application, you would hook up one wire from your IAQ device to the upper U terminal and the other to the common side of the cooling transformer. The 1 wire setting is most commonly used when using a fresh air damper for ventilation or using low speed fan for dehumidification.
- See wiring examples on the next page.

Wiring Diagrams

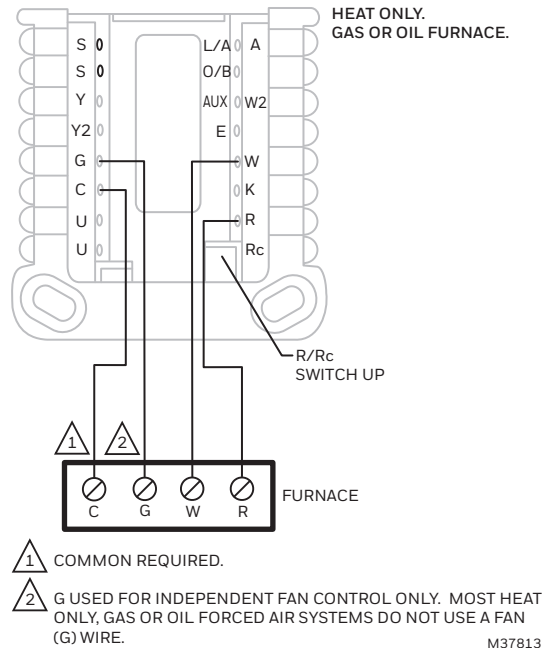

Fig. 12. Heat only: gas or oil furnace.

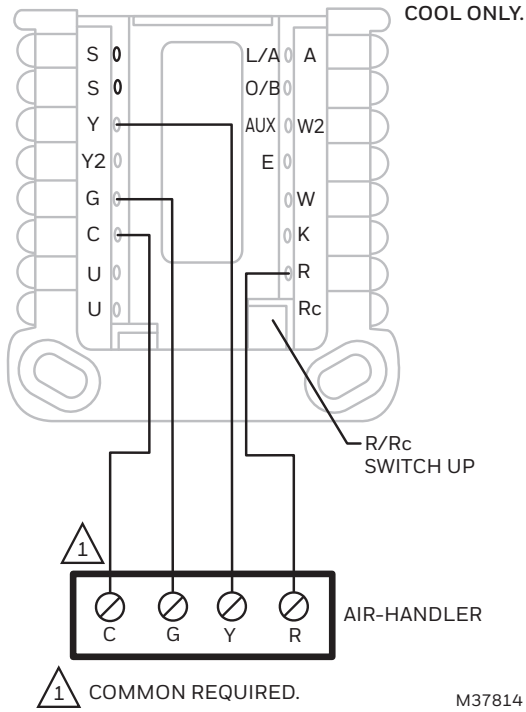

Fig. 13. Cool only.

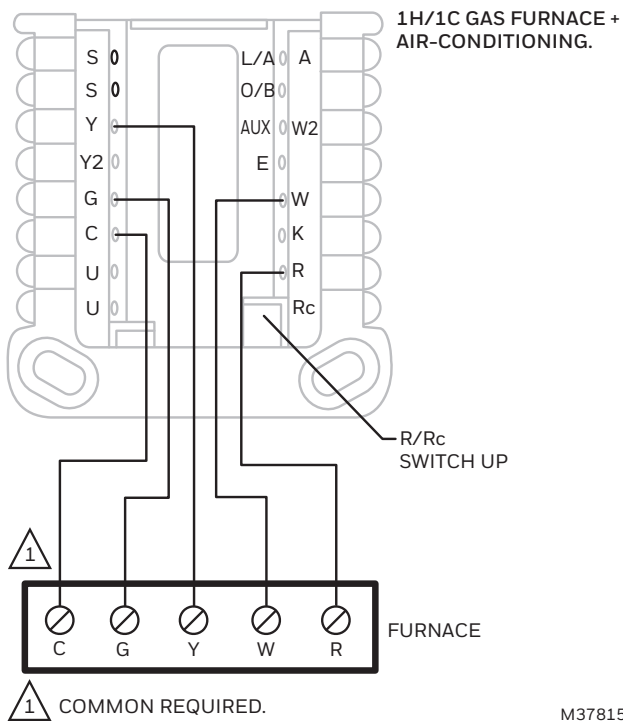

Fig. 14. 1H/1C gas furnace.

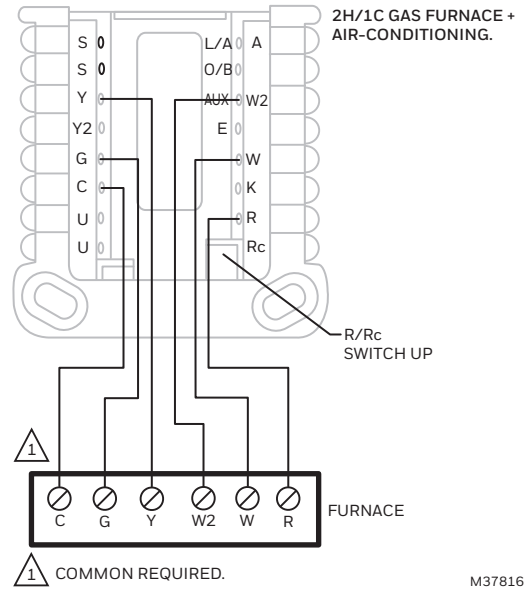

Fig. 15. 2H/1C gas furnace.

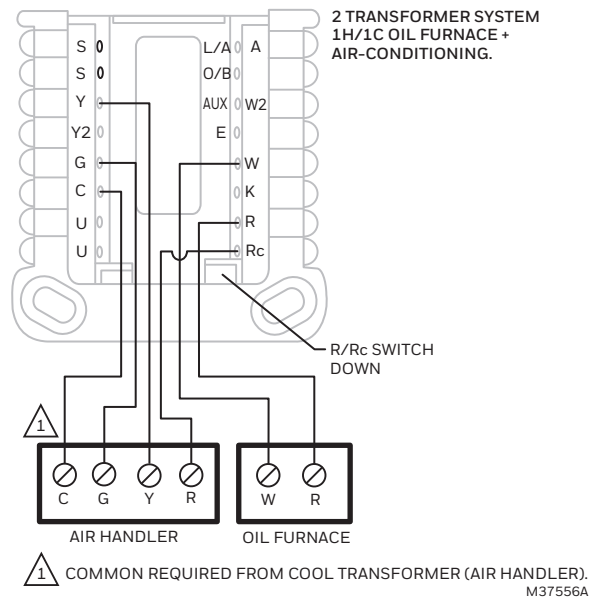

Fig. 16. 2 Transformer system; 1H/1C oil furnace.

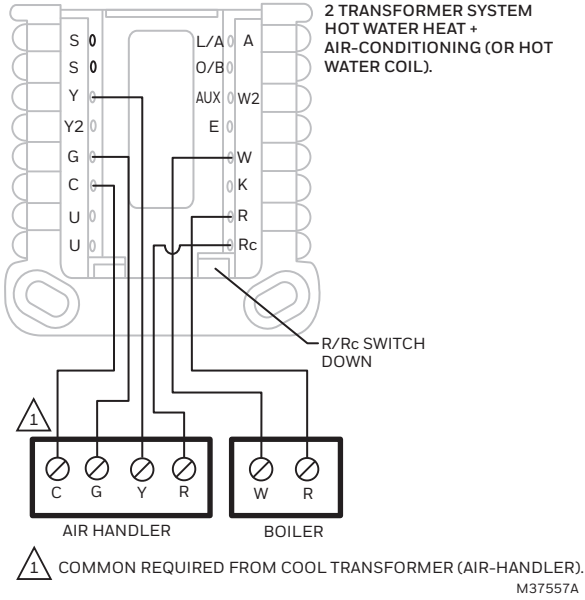

Fig. 17. 2 Transformer system; hot water heat with air-conditioning (or hot water coil).

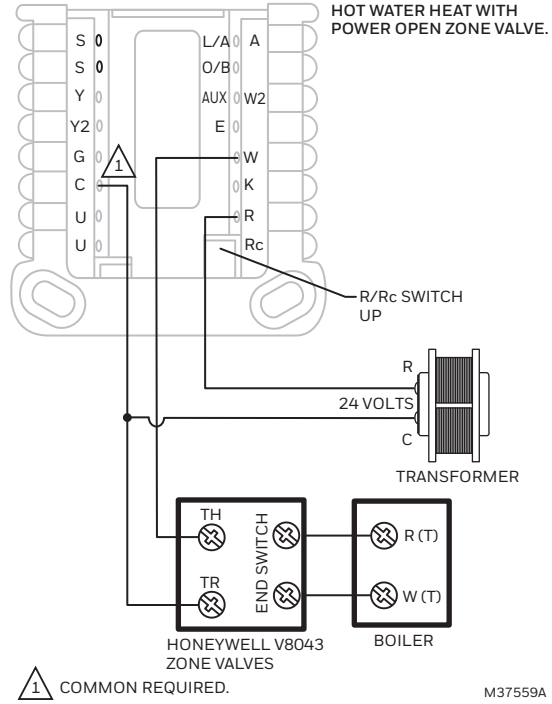

Fig. 19. Hot water heat with power open zone valve.

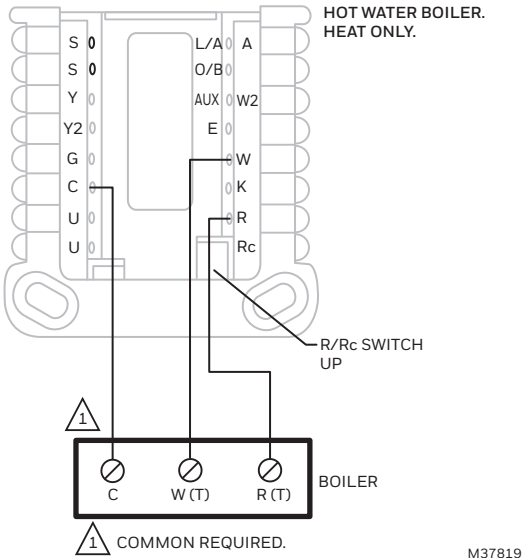

Fig. 18. Hot water boiler, heat only.

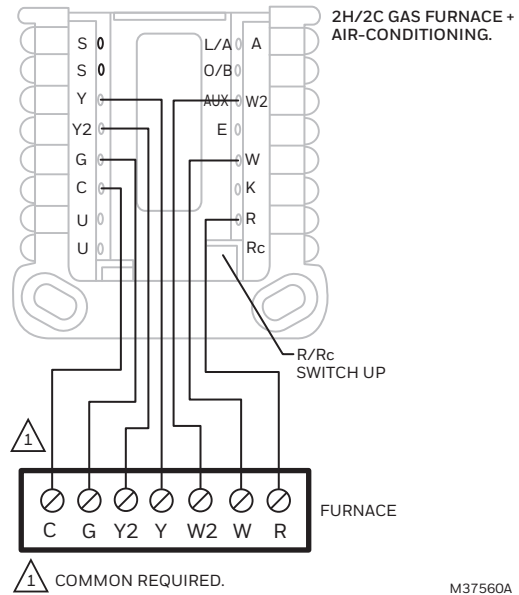

Fig. 20. 2H/2C: gas furnace.

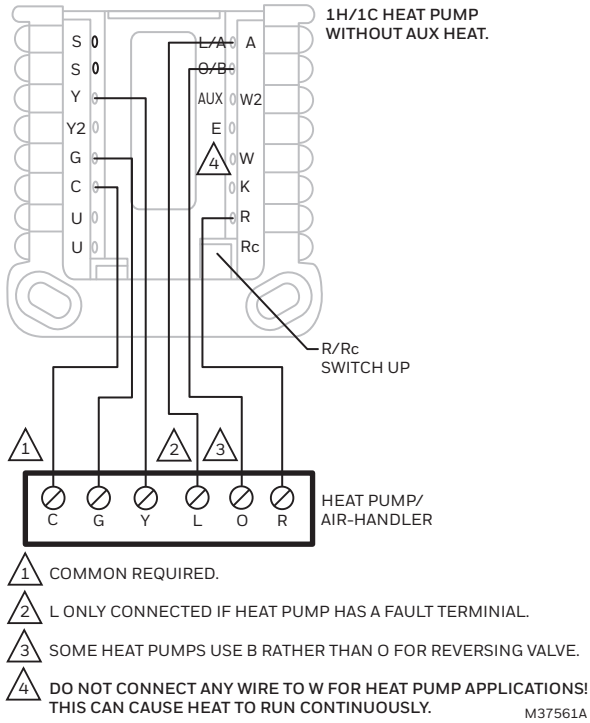

Fig. 21. 1H/1C heat pump without aux heat.

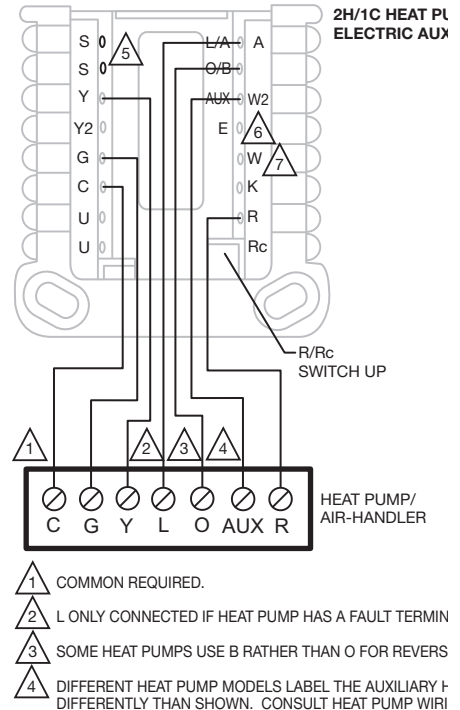

Fig. 22. 2H/2C heat pump with electric aux heat.

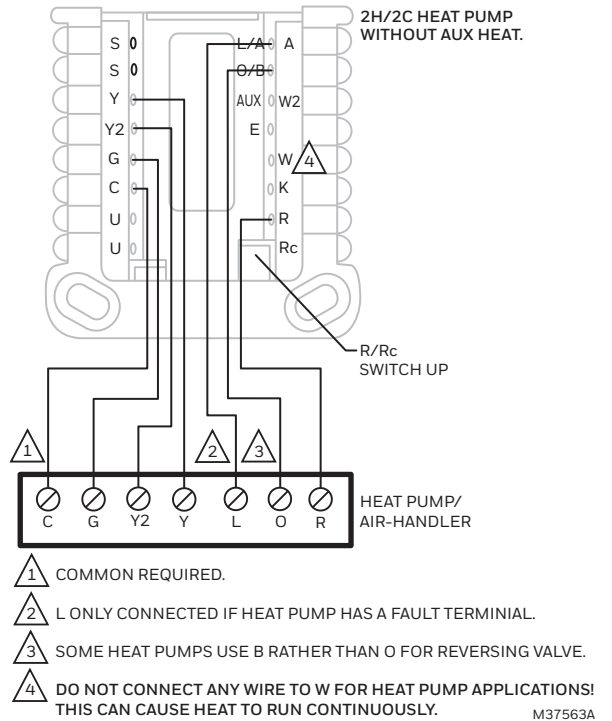

Fig. 23. 2H/2C heat pump without aux heat.

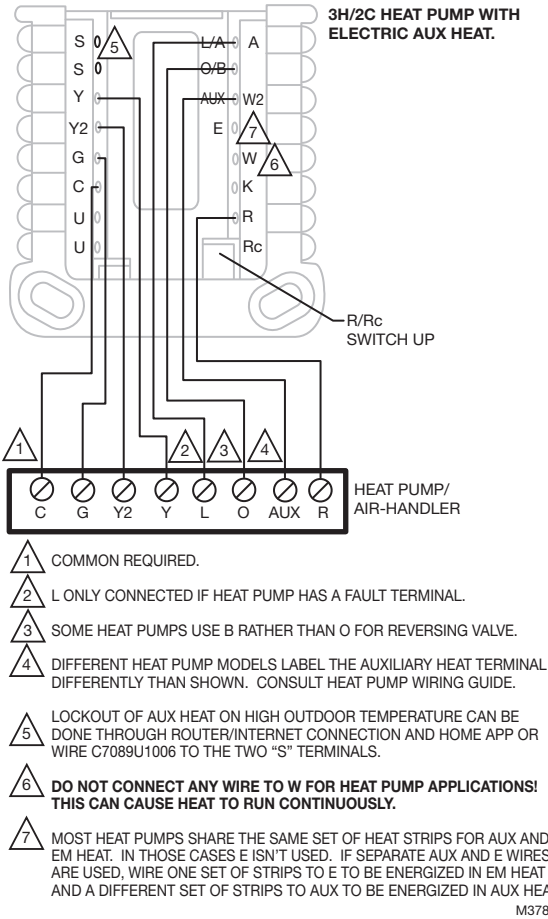

Fig. 24. 3H/2C heat pump with electric aux heat.

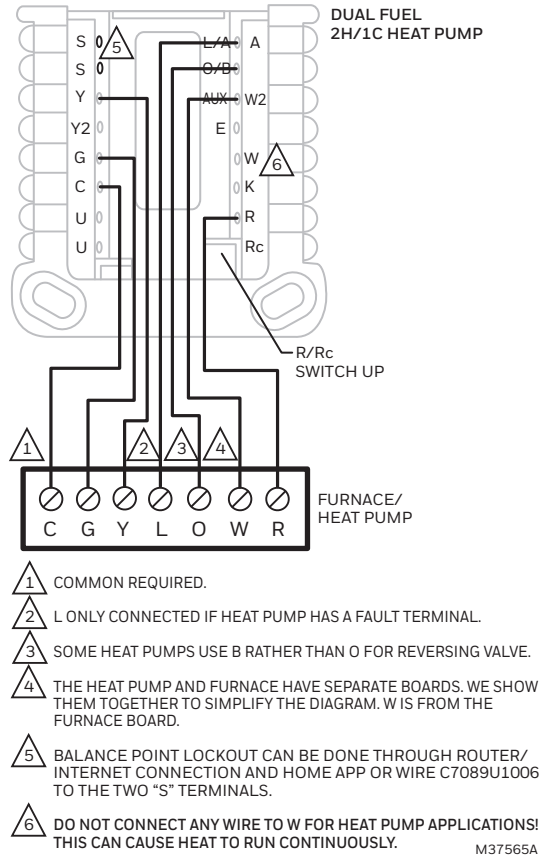

Fig. 25. Dual fuel 2H/1C heat pump.

Whole house humidifier, dehumidifier, or ventilator wiring

Using U Slider Tab

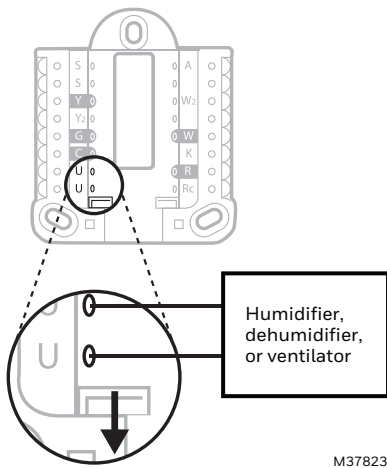

Fig. 26. Wired to humidifier, dehumidifier, or ventilator with built-in transformer.

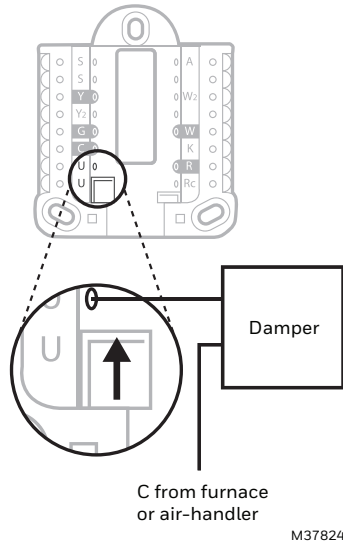

Fig. 27. Wired to fresh air damper powered by furnace transformer.

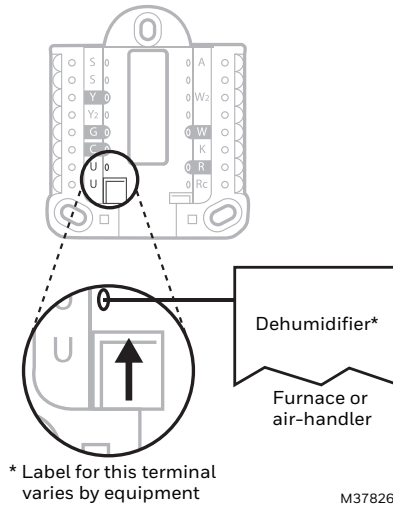

Fig. 29. Wired to low speed fan terminal on HVAC for dehumidification.

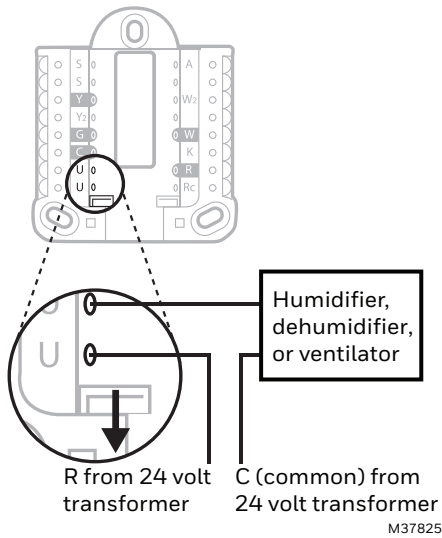

Fig. 28. Wired to humidifier, ventilator, or damper powered by external transformer.

Mounting thermostat

1. Push excess wire back into the wall opening.
2. Close the UWP door. It should remain closed without bulging.
3. Align the UWP with the thermostat, and push gently until the thermostat snaps in place.
4. If needed, gently pull to remove the thermostat from the UWP.

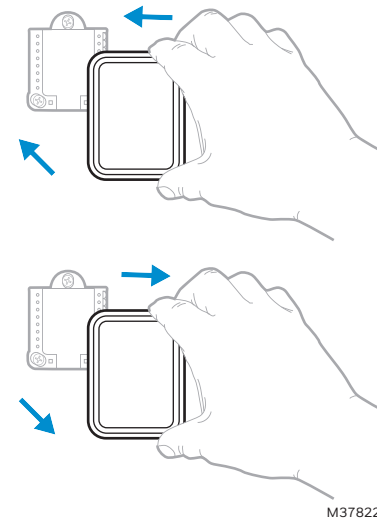

Fig. 30. Mounting or removing the thermostat.

Mounting Optional Accessories

Installing RedLINK indoor sensors

The C7189R2002-2 indoor sensor 2 pack is included with the T10 thermostat. These sensors detect Temperature, humidity and motion.

Up to 20 of these optional indoor sensors can be used with the T10 thermostat. These sensors can be used to sense

temperature from a different location than the thermostat, average temperature from multiple locations, or control the temperature based on sensor priority (through scheduling, manually selecting priority sensors, or prioritizing active rooms.

The T10 can prioritize active rooms using the motion detectors in the indoor sensors.



Fig. 31. C7189R2002-2 indoor sensor 2 pack

Placement Tips

- DO place about 5 feet above the floor.
- DO place on inside walls.
- DON'T place behind furniture or doors.
- DON'T place in direct sunlight.
- DON'T place above air vents.

See Fig. 32.

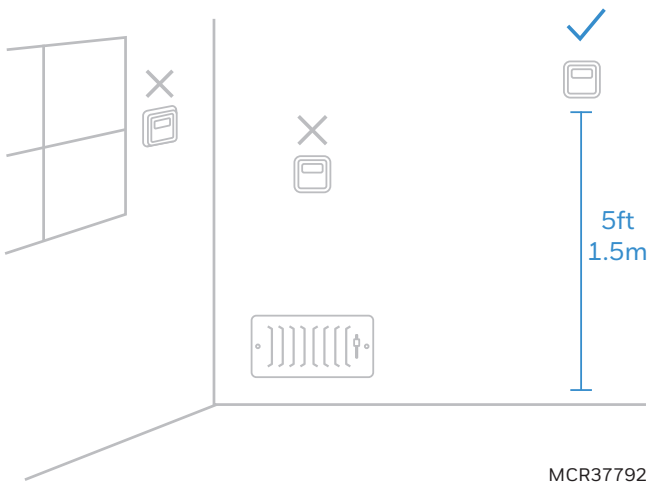

Fig. 32.

These sensors can be linked to the thermostat when doing the initial Installer setup or at a later date.

- During initial installer setup, the thermostat will offer setup options under “RedLINK Devices” for “Add device” or “Set up later”.
- To add a sensor after initial setup has been done, select the menu icon, then “Devices & Sensors”, then “Add”.
 - The display screen will walk you through linking and naming the sensor.

Installing RedLINK indoor sensors

C7189R2002 Wireless Indoor Sensor

Use the following steps to mount the sensor.

1. Remove the wallplate and mount it 4 to 6 feet above the floor on an interior wall. Drill 3/16-inch holes for drywall, 7/32-inch for plaster.
2. Attach sensor securely to wallplate as shown.

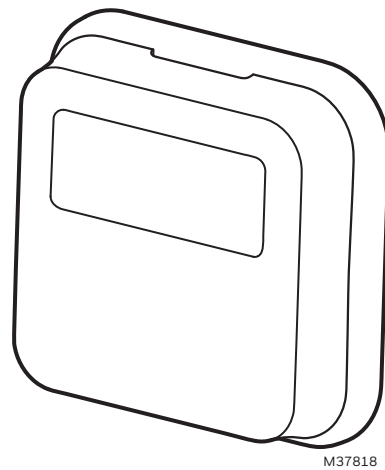

Fig. 33.

The thermostat will prompt you to connect RedLINK devices during initial setup. If the sensors were not connected to the thermostat at that time:

1. Open the Menu
2. Tap “Devices & Sensors”
3. Tap “Add”
4. Follow the on-screen instructions

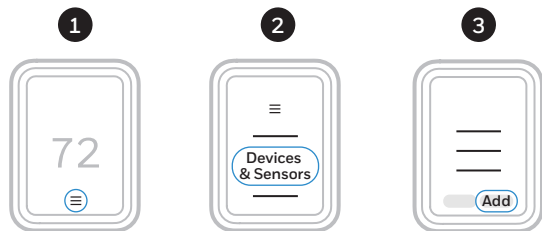

Fig. 34.

Installing Wired Indoor Sensor

C7189U1005 (10K) Wired Indoor Sensor

ISU setting 5000 on page 23.

Use the following steps to mount the sensor:

1. Remove the cover from the remote sensor see Fig. 35.

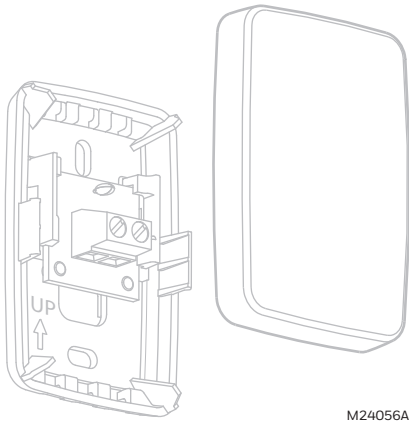

Fig. 35. Remove the cover

2. Pull wires through wire hole.
3. Position wallplate on wall, level and mark screw hole positions with pencil.
4. Drill holes at marked positions, then tap in supplied wall anchors.
5. Place wallplate over anchors, insert and tighten mounting screws see Fig. 36.

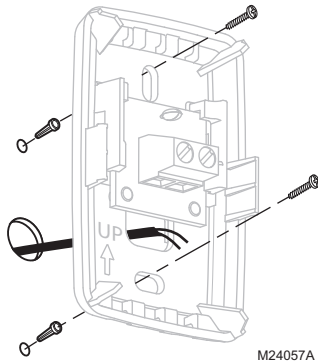

Fig. 36. Mount wallplate to wall

6. Replace the cover on the remote sensor.



CAUTION

Electrical Shock Hazard.
Can cause electrical shock or equipment damage.

Disconnect power supply before connecting wiring.

Wiring 1 C7189U1005 sensors (10k ohm) for temperature control. Select 10K in the Installer Setup (ISU 5030) when using C7189U1005 sensor(s).

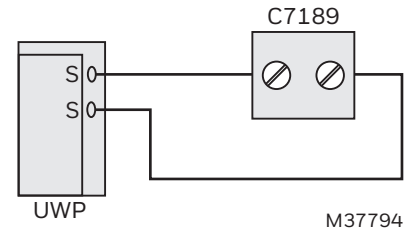

Fig. 37. Wiring 1 C7189I sensor.

Wiring 4 C7189U1005 sensors (10k ohm) for temperature averaging network. Select 10K in the Installer Setup (ISU 5030) when using C7189U1005 sensor(s).

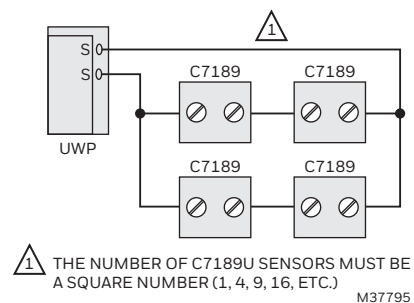

Fig. 38. Wiring 4 C7189U sensors.

Installing Wired outdoor sensor

See ISU setting “outdoor temperature” on page 17 for correct thermostat configuration.

Follow instructions included with C7089U1006 wired outdoor sensor.

Location and Mounting (Fig. 39)

Mount the sensor where:

- cannot tamper with settings.
- there is good air circulation.
- it can measure true outdoor ambient temperature.
- surface is flat.
- wire distance between C7089U and thermostat is less than 200 feet.

Do not mount the sensor:

- in direct sunlight.
- where hot or cold air blows on the sensor. Discharge line from an outdoor compressor unit, vent or fan causes inaccurate temperature readings.
- where snow, ice or debris can cover it.

Use the following steps to mount the sensor:

1. Remove the sensor from the mounting clip.
2. Mark the area on the location selected for mounting the sensor mounting clip.
3. Mount the clip.

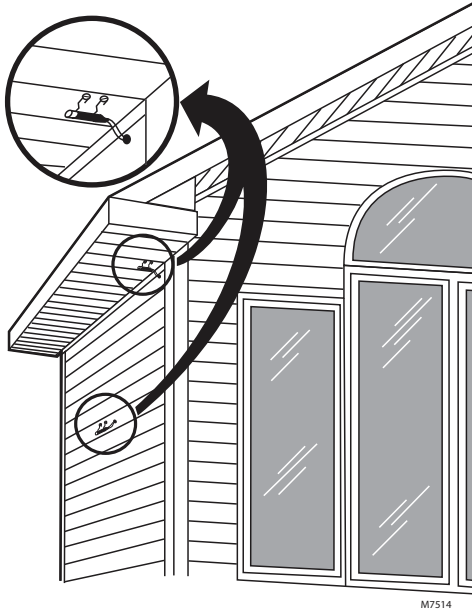

Fig. 39.

CAUTION

**Electrical Interference (Noise) Hazard.
Can cause erratic system operation.**

Keep wiring at least one foot away from large inductive loads such as motors, line starters, lighting ballasts and large power distribution panels.
Use shielded cable to reduce interference when rerouting is not possible.

IMPORTANT

Erratic temperature readings from a sensor can occur as a result of any of the wiring practices described below. Avoid these practices to assure correct operation. Use shielded cable to reduce interference if rerouting of sensor wiring is not possible.

- Be sure wires have a cable separate from the thermostat cable.
- Do not route temperature sensor wiring with building power wiring, next to control contactors or near light dimming circuits, electric motors or welding equipment.
- Avoid poor wiring connections.
- Avoid intermittent or missing building earth ground.

Installer setup (new installation)

1. After the thermostat has powered up, touch “GET STARTED” on the thermostat.
2. After selecting the correct option for each setting, Touch NEXT at the bottom of the display to advance to the next option.
3. To see a list of all setup parameters, go to “Installer setup (ISU)” starting on page 17. The thermostat displays the ISU name.
4. To finish setup and save your settings, TOUCH “Done” in the upper left of display

Installer setup (revising settings)

If this is not a new installation and you want to access the Installer setup to change settings:

1. Touch the menu icon (3 horizontal lines at bottom of display)
2. Scroll down and touch “Thermostat Information”.
3. Write down the date code from that screen. The touch the left arrow at top of display to go to previous screen.
4. Scroll down until “installer Options” is shown. Touch “installer options” and enter date code.
5. Select “installer Setup”.
6. After selecting the correct option for each setting, Touch NEXT at the bottom of the display to advance to the next option.
7. To see a list of all setup parameters, go to “Installer setup (ISU)” starting on page 17.
8. To finish setup and save your settings, TOUCH “Done” in the upper left of display



MCR37796

Fig. 40.

Table 5. Installer Setup (ISU)

ISU #	Installer Setup Name	Settings	Default	Notes
None	Language	<ul style="list-style-type: none"> English Francais Espanol 	Engligh	
None	Room	<ul style="list-style-type: none"> Bedroom Living space Other 	No defaulted value	In what type of room will this thermostat be installed? These questions are asked for two reasons: <ol style="list-style-type: none"> Other RedLINK indoor sensors could be used for other spaces in the home. When these sensors are used, the customer is able to select certain sensors to have priority under certain conditions (active rooms based on motion detection, selected rooms based on schedule settings). There may be multiple thermostats in the same location controlled via the app.
None	Room	Bedroom: <ul style="list-style-type: none"> Guest Bedroom Master Bedroom Add room Living Space: <ul style="list-style-type: none"> Family room Living Room Rec Room Add room Other: <ul style="list-style-type: none"> Dining Room Kitchen Basement Hallway Add room 		
None	Units	<ul style="list-style-type: none"> Fahrenheit Celsius 	Fahrenheit	Which temperature scale would you like to use?
None	RedLINK Devices	<ul style="list-style-type: none"> Add device Set up later 		Use to connect RedLINK wireless Accessories. List of compatible RedLINK accessories shown on page 4. Thermostat display will guide you through linking RedLINK accessories to thermostat.
None	Outdoor temperature	<ul style="list-style-type: none"> None Wired Internet 	None	Outdoor temperature is used for balance point lockout, aux heat lockout, frost control, high and low outdoor temperature lockouts for ventilation
2000	System Type	<ul style="list-style-type: none"> Conventional Forced Air Heat Heat Pump Radiant Heat None (cool only) 	Conventional Forced Air Heat	
2010	Equipment Type	Conventional Forced Air Heat <ul style="list-style-type: none"> Standard Efficiency Gas Forced Air High Efficiency Gas forced air Oil Forced Air Electric Forced Air Hot water Fan Coil Heat Pump <ul style="list-style-type: none"> Air to Air Geothermal Radiant Heat <ul style="list-style-type: none"> Hot Water Radiant Heat Steam None (cool only)		This ISU is not displayed when ISU 2000 Heating System Type is set to None (Cool Only). Available options depend on "System Type" setting Cycle Rate and Fan Operation automatically default to the correct settings based on the equipment type selected.
2060	Reversing Valve	<ul style="list-style-type: none"> O (O/B on Cool) B (O/B on Heat) 	O (O/B on Cool)	Only displayed if the system type (ISU 2000) is set to Heat Pump

Table 5. Installer Setup (ISU)

ISU #	Installer Setup Name	Settings	Default	Notes
2070	Cool Stages / Compressor stages	0, 1, 2	1	0 setting not available if the system type (ISU 2000) is set to Heat Pump
2071	Heat stages / Backup heat stages	0, 1, 2	1	Maximum of 2 Heat Stages for conventional systems. Maximum of 1 Backup Heat Stages for heat pump applications. Note: this is not counting the compressor heat stages on heat pump systems.
2110	Fan Operation in Heat	<ul style="list-style-type: none"> Equipment controls fan Thermostat controls fan 	Thermostat controls fan	This ISU is only displayed if ISU 2010 is set for Electric Forced Air or Hot Water Fan Coil. The thermostat automatically energizes the fan in heat when running a heat pump. The thermostat automatically allows the system to run the fan in heat when set for gas or oil forced air systems. For radiant systems (excluding hot water fan coil) the thermostat does not energize fan in heat.
2175	Aux/E terminal control	<ul style="list-style-type: none"> Drive aux and E together Aux and E Independent 	Drive aux and E together	Only displayed if the system type (ISU 2000) is set to Heat Pump) and Backup heat stages (ISU 2071) is set to 1. Change to Aux and E Independent only when you have separate wires to Aux and E terminals on UWP and want the AUX wire energized with heat pump as backup heat and E energized separate of heat pump when switched to em heat mode.
2180	Backup Heat Type	<ul style="list-style-type: none"> Electric Forced Air Standard Efficiency Gas Forced Air High Efficiency Gas Forced Air 	Electric Forced Air	Only displayed if the system type (ISU 2000) is set to Heat Pump) and Backup heat stages (ISU 2071) is set to 1.
2185	Emergency Heat Type	<ul style="list-style-type: none"> Electric Forced Air Standard Efficiency Gas Forced Air High Efficiency Gas Forced Air 	Electric Forced Air	Only displayed if the Aux/E terminal control (ISU 2175) is set to "Aux and E Independent".
2190	External Fossil Fuel Kit	<ul style="list-style-type: none"> Thermostat controls Backup Heat External Fossil Fuel kit controls backup heat 	Thermostat controls Backup Heat	Not displayed if equipment type (ISU 2000) is set to cool only or cool stages (ISU 2070) is set to 0. This ISU is only displayed when ISU 2000 System Type is Heat Pump and ISU 2180 Backup Heat Type is Standard Efficiency Gas Forced Air or High Efficiency Gas Forced Air.
3000	Changeover	<ul style="list-style-type: none"> Manual Automatic 	Automatic	Not displayed if equipment type (ISU 2000) is set to cool only or cool stages (ISU 2070) is set to 0.
3015	Auto Changeover differential	0 °F-3 °F (0.0 °C-2.5 °C)	0	Differential is the minimum number of degrees rise or fall required during off cycle to switch from the last active mode (heat or cool) to the opposite mode when the thermostat is in auto-changeover. Differential is NOT deadband. See Auto Changeover operation on page 37.

Table 5. Installer Setup (ISU)

ISU #	Installer Setup Name	Settings	Default	Notes
3020	Finish with high cool stage	<ul style="list-style-type: none"> No Yes 	No	This ISU is only displayed when the thermostat is set for 2 cool stages. When set to Yes, then once the thermostat has upstaged to stage 2 cool, this feature keeps the high stage of the cooling equipment running until the desired setpoint is reached.
3021	Finish with high heat stage	<ul style="list-style-type: none"> No Yes 	No	This ISU is only displayed when the thermostat is set for 2 heat stages. Or a heat pump with 2 compressor stages and/or an aux heat stage. When set to Yes, then once the thermostat has upstaged to stage 2 cool, this feature keeps the high stage of the cooling equipment running until the desired setpoint is reached.
3090	Backup Heat Differential	<p>Fahrenheit: Comfort, 2.0° F to 15.5° F from setpoint (in 0.5° F increments)</p> <p>Celsius: Comfort, 1.00° C to 7.5° C from setpoint (in 0.5° F increments)</p>	Comfort if backup heat is electric 2.0F if backup heat is gas furnace.	Only displayed if the system type (ISU 2000) is set to Heat Pump). If ISU 2180 (backup heat type) is set to electric, the default control setting is comfort. If ISU 2180 (backup heat type) is set to Gas furnace, the default control setting is 2F and "Comfort" is not an option. If set to other than "comfort" the indoor temperature must drop to the selected differential setting before the thermostat will turn on backup heat stage 2. For example, if backup heat stage 2 is set to 2°F (1.0° C), the indoor temperature must be 2° F (1.0° C) away from the setpoint before backup heat stage 2 turns on. When set to Comfort, the thermostat will use backup heat stage 2 as needed to keep the indoor temperature within 1° F (0.5° C) degree of the setpoint.
3110	Backup Heat Upstage Timer	Off (30, 45, 60, 75, 90) minutes (2, 3, 4, 5, 6, 8, 10, 12, 14, 16) hours	Comfort if backup heat is electric 2.0F if backup heat is electric	The Backup Heat Upstage Timer starts when the highest stage of the Heat Pump turns on. Backup heat will be used (if needed) when the timer expires. See "Backup Heat Upstage Timer" on page 38. This ISU is only displayed when Backup Heat Differential is set to 2 F or higher (ISU 3090).
3120	Compressor Lockout Balance point	<p>Fahrenheit: Off -15° F to 60° F (in 5° F increments)</p> <p>Celsius: Off -26° C to 15.5° C (in varying increments)</p>	Off	ISU 3120 Compressor Lockout / Balance Point requires a wired outdoor sensor or Internet weather (thermostat connected to Wi-Fi and registered to an account). Default is 40 F if ISU 2010 Heating Equipment Type is Air to Air Heat Pump and ISU 2180 Backup Type is gas or oil forced air. Default is Off if ISU 2010 Heating Equipment Type is Air to Air Heat Pump and ISU 2180 Backup Type is electric forced air. Default is Off if ISU 2010 Heating Equipment Type is Geothermal Heat Pump. See "Heat pump with outdoor temperature lockouts" on page 40.

Table 5. Installer Setup (ISU)

ISU #	Installer Setup Name	Settings	Default	Notes
3120	Backup Heat Lockout	<p>Fahrenheit: Off 5° F to 65° F (in 5° F increments)</p> <p>Celsius: Off -15.0° F to 18.5° F (in 5° F increments)</p> <p>Note: When both Compressor lockout balance point and Backup Heat Lockout are set to other than “off”, the Backup heat lockout must be at least 5 degrees F above the balance point setting</p>	Off	<p>This ISU is used to lockout the auxiliary heat when outdoor temperature is above this setting. A 5 degree minimum differential is enforced between balance point and backup heat lockout settings.</p> <p>ISU 3120 Backup Heat Outdoor Temperature Lockout requires a wired outdoor sensor or Internet weather (thermostat connected to Wi-Fi and registered to an account).</p> <p>ISU 3120 defaults to off and is not adjustable unless if ISU 1060 (outdoor Temperature) is set to either Wired or Internet.</p> <p>ISU 3120 is only displayed if ISU 2000 (System Type) is set to Heat Pump, and 2071 (backup heat stages) is set to 1.</p> <p>See “Heat pump with outdoor temperature lockouts” on page 40.</p> <p>NOTE: This is most commonly used when backup heat is electric. For dual fuel systems (Heat pump with gas or oil backup) in which a balance point is used to switch from heat pump to gas or oil furnace, if the outdoor temperature is at the Backup Heat Lockout setting, it is also above the balance point setting. When both balance point and Aux heat lockout are used on dual fuel, if the thermostat is locking out heat pump due to droop or upstage timer, and reaches the Backup Heat Lockout setting, then neither furnace nor heat pump would run during a heat call.</p> <p>Contractors typically only use this setting on dual fuel applications as a warm weather shut down setting for the furnace.</p>
3140	Cool / Compressor Cycles Per Hour Stage 1	1-6	3	<p>This ISU is only displayed when ISU 2070 Cool / Compressor Stages is set to 1 or 2 stage.</p> <p>Cycle rate limits the maximum number of times the system can cycle in a 1 hour period measured at a 50% load. For example, when set to 3 CPH, at a 50% load, the most the system will cycle is 3 times per hour (10 minutes on, 10 minutes off). The system cycles less often when load conditions are less than or greater than a 50% load.</p>
3140	Cool / Compressor Cycles Per Hour Stage 2	1-6	3	<p>This ISU is only displayed when ISU 2070 Cool / Compressor Stages is set to 2 stage.</p> <p>Cycle rate limits the maximum number of times the system can cycle in a 1 hour period measured at a 50% load for the active stage.</p>

Table 5. Installer Setup (ISU)

ISU #	Installer Setup Name	Settings	Default	Notes
3150	Heat Cycles Per Hour Stage 1	1-12	Default varies based on heating equipment type selected	This ISU is only displayed when ISU 2000 is not set for heat pump and ISU 2070 Heat Stages is set to 1 or 2 stages. Cycle rate limits the maximum number of times the system can cycle in a 1 hour period measured at a 50% load. For example, when set to 3 CPH, at a 50% load, the most the system will cycle is 3 times per hour (10 minutes on, 10 minutes off). The system cycles less often when load conditions are less than or greater than a 50% load. The thermostat automatically defaults to the recommended cycle rate based on the heating equipment type that is used. You can change the cycle rate as needed. Defaults for commonly used systems are shown below. Standard Efficiency Gas Forced Air = 5 CPH High Efficiency Gas Forced Air = 3 CPH Oil Forced Air = 5 CPH Electric Forced Air = 9 CPH Hot Water Fan Coil = 3 CPH Hot Water Radiant Heat = 3 CPH Steam = 1 CPH
3150	Heat Cycles Per Hour Stage 2	1-12	Default varies based on heating equipment type selected	This ISU is only displayed when ISU 2071 Heat stages is set to 2 stage for conventional forced air systems. Cycle rate limits the maximum number of times the system can cycle in a 1 hour period measured at a 50% load for the active stage.
3160	Backup Heat Cycles per Hour	1-12	Default varies based on backup heating equipment type selected	This ISU is only displayed when ISU 2000 is set for heat pump and ISU 2071 is set for 1 aux heat stage. Cycle rate limits the maximum number of times the system can cycle in a 1 hour period measured at a 50% load for the active stage.
3165	Emergency Heat Cycles per Hour	1-12	Default varies based on backup heating equipment type selected	This ISU is only displayed when ISU 2175 Aux/E terminal control is set for "Aux and E Independent". Cycle rate limits the maximum number of times the system can cycle in a 1 hour period measured at a 50% load. For example, when set to 3 CPH, at a 50% load, the most the system will cycle is 3 times per hour (10 minutes on, 10 minutes off). The system cycles less often when load conditions are less than or greater than a 50% load. The thermostat automatically defaults to the recommended cycle rate based on the heating equipment type that is used. You can change the cycle rate as needed. Defaults for commonly used emergency heat shown below. Standard Efficiency Gas Forced Air = 5 CPH High Efficiency Gas Forced Air = 3 CPH Electric Forced Air = 9 CPH

Table 5. Installer Setup (ISU)

ISU #	Installer Setup Name	Settings	Default	Notes
3240	Minimum Compressor Off Time	Off, 1-5 minutes	5	The thermostat has a built in compressor protection (minimum off timer) that prevents the compressor from restarting too early after a shutdown. The minimum-off timer is activated after the compressor turns off. If there is a call during the minimum-off timer, the thermostat shows “waiting for equipment” in the display.
3260	Extended fan run time in cool	0, 30, 60, 90 seconds, 2, 3, 4, 5, 6, 7, 8, 9, 10, 11, 12, 13, 14, 15 minutes	0 seconds	After the call for cooling ends, the thermostat keeps the fan on for the selected amount of time for increased efficiency. This may reintroduce humidity into the living space.
3260	Extended fan run time in heat	0, 30, 60, 90 seconds, 2, 3, 4, 5, 6, 7, 8, 9, 10, 11, 12, 13, 14, 15 minutes	0 seconds	After the call for heating ends, the thermostat keeps the fan on for the selected amount of time for increased efficiency.
4090	Adaptive Intelligent Recovery	<ul style="list-style-type: none"> • No • Yes 	Yes	<p>No: The system will begin heating or cooling recovery at the scheduled time.</p> <p>Yes: The thermostat will begin heating or cooling recovery early to ensure that the temperature is reached at the scheduled time. The thermostat will adjust the start time of the equipment based on how quickly the scheduled temperature was reached on previous days.</p>
4100	Minimum Cool Setpoint	50° F to 99° F * 10.0° C to 36.5° C	50° F (10° C)	The user cannot set the cool setpoint below this level. Thermostat needs to be configured for at least 1 cool/compressor stage. * The minimum cool setpoint cannot be set higher than the maximum cool setpoint. If these settings are the same, the cool setpoint is not adjustable from homescreen.
4100	Maximum Cool Setpoint	50° F to 99° F * 31° C to 37° C	90° F (32° C)	The user cannot set the cool setpoint above this level. Thermostat needs to be configured for at least 1 cool/compressor stage. * The maximum cool setpoint cannot be set lower than the minimum cool setpoint. If the max cool and min cool settings are the same, the cool setpoint is not adjustable from homescreen.
4100	Minimum Heat Setpoint	40° F to 90° F * 4.5° C to 32° C	50° F (10° C)	The user cannot set the Heat setpoint below this level. Thermostat needs to be configured for at least 1 heat stage. * The minimum heat setpoint cannot be set higher than the maximum heat setpoint or the minimum cool. If these settings are the same, the heat setpoint is not adjustable from homescreen.
4100	Maximum Heat Setpoint	40° F to 90° F * 4.5° C to 32° C	90° F (32° C)	The user cannot set the Heat setpoint above this level. Thermostat needs to be configured for at least 1 heat stage. * The maximum heat setpoint cannot be set lower than the minimum heat setpoint. If these settings are the same, the heat setpoint is not adjustable from homescreen.

Table 5. Installer Setup (ISU)

ISU #	Installer Setup Name	Settings	Default	Notes
4110	Keypad Lockout	<ul style="list-style-type: none"> • Unlocked • Partially locked • Fully locked 	Unlocked	Unlocked: User has access to all thermostat settings. Partially Locked: User can modify only temperature settings. Fully Locked: User cannot modify any settings
5000	Is an indoor sensor WIRED to your System?	Indoor air temperature	Unchecked box (no indoor sensor used)	Select this if a wired indoor sensor is connected to the S terminals. Outdoor wired sensor can be selected at the ISU prior to 2000 for "outdoor temperature". * You cannot use both a wired outdoor and wired indoor sensor, so if "outdoor temperature" is set to wired sensor, ISU 5000 will not be shown.
5030	Indoor temperature sensor type	10K 20K	10K	Select 10K or 20K based on the sensor installed. Refer to resistance values below: C7189U1005 = 10K ohm See "Installing Wired Indoor Sensor" on page 14 for information wiring multiple indoor sensors.
5040	Which Sensors will be used for Temperature Control? (Multiple sensors are averaged)	Thermostat Remote Sensor	Both	Select whether the internal thermostat sensor or wired sensor(s) are used. If both thermostat and remote sensor are selected, the thermostat would count for 50% of the average and all wired sensors combined would count for the other 50% of the average. This setting does not pertain to the Wireless indoor sensors. You can select which of those are used for control temperature under Menu-Priority from the home screen. See "Installing Wired Indoor Sensor" on page 15 for information wiring multiple indoor sensors.
7000	Filter Type	<ul style="list-style-type: none"> • None • Media 	None	
7020	Number of air filters	0-2	1	Only shown if ISU 7000 is set to media
7110	Air filter 1 replacement reminder	Off Run Time: 10, 20, 30 45, 60, 90, 120, 150 days Calendar: 30, 45, 60, 75 days 3, 4, 5, 6, 9, 12, 15 months	Off	Only shown if ISU 7020 is set to 1 or 2
7110	Air filter 2 replacement reminder	Off Run Time: 10, 20, 30 45, 60, 90, 120, 150 days Calendar: 30, 45, 60, 75 days 3, 4, 5, 6, 9, 12, 15 months	Off	Only shown if ISU 7020 is set to 2
8000	What type of humidifier do you have?	<ul style="list-style-type: none"> • None • Steam • Bypass or fan powered 	None	

Table 5. Installer Setup (ISU)

ISU #	Installer Setup Name	Settings	Default	Notes
8050	Humidification Window Protection	<ul style="list-style-type: none"> Off On 	Off	Requires either wired outdoor sensor or Internet weather (thermostat connected to Wi-Fi and registered to the app). Off: The thermostat controls the humidity level to the user's desired humidity setting. Frost or condensation may appear on windows. On: The thermostat prevents frost or condensation on windows by not allowing the humidity to go above the "Window Limit" when it is controlling the humidifier. The "Window Limit" is based on the current outdoor temperature and the user's window protection setting. The "Window Limit" is displayed on the user's humidification screen. See "Window Protection" on page 34.
8060	System modes allowing Humidification	<p>Check box on screen for each:</p> <ul style="list-style-type: none"> Heat Off 	Heat	Click boxes on screen to select which system modes allow humidification. If a box is NOT checked, the thermostat will NOT allow humidification to operate in that mode. Heat: Includes Heat, Emergency Heat and Auto. If the system is in Auto mode, the thermostat will allow humidification if the last call was for heat. Off: The thermostat will allow humidification when the system setting is Off. See "Set up Humidification" on page 34.
8070	Humidification Control	<ul style="list-style-type: none"> Humidify Only when Heat is On Humidify Only when Fan is On Humidify on Demand: Thermostat Controls Fan Humidify on Demand: Humidifier Controls Fan 	Defaults to Humidify Only when Heat is On when ISU 8000 Humidifier Type is Bypass or Fan Powered. Defaults to Humidify on Demand: Thermostat Controls Fan when ISU 8000 Humidifier Type is Steam	Humidify Only when Heat is On: The thermostat turns on the humidifier only if the heat is currently running. Humidify Only when Fan is On: The thermostat turns on the humidifier only if the fan is currently running. Humidify on Demand - Thermostat Controls Fan: The thermostat turns on the humidifier and the fan when humidification is needed. Humidify on Demand - Humidifier Controls Fan: The thermostat turns on the humidifier when humidification is needed and the humidifier controls the fan.
8100	Humidifier Pad Replacement Reminder	<ul style="list-style-type: none"> Off 60 Run Time Days 90 Run Time Days 6 Calendar Months 12 Calendar Months 	Off	This ISU is only displayed if ISU 8000 Humidifier Type is Bypass or Fan Powered or none. Run Time Days are not shown if ISU 8000 Humidifier Type is set to None
8100	Clean Tank/Water Filter	<ul style="list-style-type: none"> Off 60 Run Time Days 90 Run Time Days 6 Calendar Months 12 Calendar Months 	Off	This ISU is only displayed if ISU 8000 Humidifier Type is Steam.
9000	What Type of Dehumidifier Equipment Do you Have?	<ul style="list-style-type: none"> None A/C with Low Speed Fan A/C with High Speed Fan Whole House Dehumidifier 	None	See "Dehumidification" on page 34. Whole House Dehumidification and A/C with Low speed Fan only available if not configured to control a Humidifier or Ventilator. A/C with low Speed Fan requires equipment that has a terminal to lower fan speed.

Table 5. Installer Setup (ISU)

ISU #	Installer Setup Name	Settings	Default	Notes
9050	Dehumidification Equipment Setup	<ul style="list-style-type: none"> Normally open Normally closed 	Normally Closed	Choose an option appropriate for the type of equipment installed. Normally Open: U contacts will normally be open and will close when the thermostat calls for dehumidification. Normally Closed: U contacts will normally be closed and will open when the thermostat calls for dehumidification.
9070	Dehumidification Overcooling Limit	0°, 1°, 2°, 3° F (0.5°, 1.0°, 1.5° C)	3	This ISU is only displayed when ISU 9000 Dehumidification Equipment is set to A/C with Low Speed Fan or A/C with High Speed Fan. The thermostat uses the cooling system to reduce humidity by lowering the temperature up to 3° F below the current cool setpoint until the desired humidity level is reached. The thermostat keeps the temperature below the cooling setpoint until the desired humidity level is reached. 0° F is only an option when ISU 9000 Dehumidification Equipment is set to A/C with Low Speed Fan.
9120	System Modes Allowing Dehumidification	<ul style="list-style-type: none"> Heat Cool Off 	<ul style="list-style-type: none"> Cool Off Default varies based on heating/cooling equipment selected	This ISU is only displayed when ISU 9000 Dehumidification Equipment is set to Whole House Dehumidifier. Click boxes on screen to select which system modes allow dehumidification. If a box is NOT checked, the thermostat will NOT allow dehumidification to operate in that mode. Heat: Includes Heat, Emergency Heat and Auto. If the system is in Auto mode, the thermostat will allow dehumidification if the last call was for heat. Cool: Includes Cool and Auto. If the system is in Auto mode, the thermostat will allow dehumidification if the last call was for cool. Off: The thermostat will allow dehumidification when the system setting is Off. See "Dehumidification" on page 34.
9130	Dehumidifier Fan Control	<ul style="list-style-type: none"> Thermostat Controls Fan Equipment Controls Fan 	Off	This ISU is only displayed when ISU 9000 is set to Whole House Dehumidifier. Thermostat Controls Fan: The thermostat turns on the dehumidifier and the fan when dehumidification is needed. Equipment Controls Fan: The thermostat turns on the dehumidifier when dehumidification is needed. The fan is controlled by the equipment.
9140	Dehumidifier Lockout	<ul style="list-style-type: none"> Dehumidifier Allowed when Cool is Running Dehumidifier Not Allowed when Cool is Running 	Dehumidifier Allowed when Cool is Running	This ISU is only displayed when ISU 9000 is set to Whole House Dehumidifier. Dehumidifier Allowed when Cool is Running: Dehumidifier can run when the cooling system is on. Dehumidifier Not Allowed when Cool is Running: Dehumidifier can NOT run when the cooling system is on.

Table 5. Installer Setup (ISU)

ISU #	Installer Setup Name	Settings	Default	Notes
9210	Dehumidification Filter Replacement Reminder	Off, 30, 60, Calendar Days 3 to 12 Calendar Months (in 1 month increments)	Off	
10000	Ventilation Type	<ul style="list-style-type: none"> None ERV/HRV Passive (Fan Only) Fresh Air Damper 	None	<p>None: The thermostat does not control ventilation.</p> <p>ERV/HRV: The thermostat controls an Energy Recovery Ventilator or Heat Recovery Ventilator for ventilation.</p> <p>Passive (Fan Only): The thermostat only turns on the fan for ventilation. This assumes the system has a damper that automatically opens whenever the fan runs.</p> <p>Fresh Air Damper: The thermostat turns on the fan and opens a fresh air damper for ventilation.</p>
10050	Ventilation Control Method	<ul style="list-style-type: none"> ASHRAE Percent on Time 	Ashrae	See "Ventilation Control Methods (ISU 10050)" on page 35.
10060	Ventilation Fan Control	<ul style="list-style-type: none"> Thermostat Controls Fan Equipment Controls Fan <p>if "fresh air damper" or "passive" is selected for ISU 10,000. This setting is not shown and thermostat controls fan by default</p>	Thermostat Controls Fan	<p>Thermostat Controls Fan: The thermostat turns on the ventilation equipment and the fan when ventilation is needed.</p> <p>Equipment Controls Fan: The thermostat turns on the ventilation equipment when ventilation is needed. The fan is controlled by the equipment.</p>
10090	Number of Bedrooms	1 to 6	2	This ISU is only displayed when ISU10050 Ventilation Control Method is set to ASHRAE.
10090	Size of house	1000 to 5000 sq. ft. (in 100 sq. ft. increments) (90 to 460 sq. m.)	1000 sq. ft.	This ISU is only displayed when ISU10050 Ventilation Control Method is set to ASHRAE.
10100	Enter Equipment Ventilation Rate	30 to 350 CFM (in 5 CFM increments) (850 - 9900 LPM)	150 CFM	This ISU is only displayed when ISU10050 Ventilation Control Method is set to ASHRAE (Residential only). This is the CFM rating of the ventilation equipment.

Table 5. Installer Setup (ISU)

ISU #	Installer Setup Name	Settings	Default	Notes
10125	Ventilation Priority	<ul style="list-style-type: none"> ASHRAE is Priority Lockouts are priority 	ASHRAE is Priority	<p>Lockouts are Priority: The thermostat places a priority on lockouts versus the ASHRAE 62.2 ventilation standard. The thermostat will not run ventilation during the following lockout conditions (if configured) unless you manually call for ventilation:</p> <ul style="list-style-type: none"> Lockout Ventilation during Outdoor Conditions (ISU 10130) Lockout Ventilation during “Sleep” program period. Note: This option is set by the user on the Ventilation screen in the Menu (under options). <p>ASHRAE is Priority: ASHRAE requires additional ventilation following a long off cycle.</p> <p>The thermostat meets the ASHRAE 62.2 ventilation standard by running additional ventilation when outdoor conditions are favorable. If ASHRAE cannot be met when outdoor conditions are favorable, the thermostat will override the outdoor lockouts and run ventilation. When using this option, it is recommended to increase the rate (CFM) of the ventilation equipment to meet the ASHRAE 62.2 ventilation standard in a shorter run time.</p>
10130	Ventilation Low Temperature Lockout	Off, -20° F to 40° F in 5° F increments. (Off, -29.0° to 4.5°C in varying increments)	Off	<p>Requires either wired outdoor sensor or Internet weather (thermostat connected to Wi-Fi and registered to the app). This ISU is only displayed when ISU 10000 Ventilation Type is set to ERV / HRV or Fresh Air Damper. See “Ventilation – Outdoor Condition Lockouts (ISU 10130)” beginning on page 36.</p>
10130	Ventilation High Temperature Lockout	Off 80° F to 110° F (in 5° F increments)	Off	
10130	Ventilation High Dew Point Lockout	Off 65° F to 85° F in 5° F increments (Off 26.5° C to 43.5° F in varying increments)	Off	
10170	Ventilator Core Cleaning Reminder	Off 3, 6, 9, 12 Calendar Months	Off	
10170	Ventilator Filter Cleaning Reminder	Off 3, 6, 9, 12 Calendar Months	Off	
11000	Number of UV Devices	0, 1, 2	0	Some systems may have two UV devices, one for the A-Coil and another for Air Treatment. A replacement reminder can be setup for each one. Select 0 if no UV devices are installed.
11050	Replace UV Bulb 1	Off, 6, 12, 24 Calendar Months	Off	
11050	Replace UV Bulb 2	Off, 6, 12, 24 Calendar Months	Off	

Table 5. Installer Setup (ISU)

ISU #	Installer Setup Name	Settings	Default	Notes
14010	Clock Format	<ul style="list-style-type: none"> 12 Hour Clock 24 Hour Clock 	12 Hour Clock	
14015	Daylight Savings Time	<ul style="list-style-type: none"> No Yes 	Yes	Set to Off in areas that do not follow Daylight Saving Time.
14020	Indoor Temperature Display Offset	-3° F to 3° F in 1° F increments (-1.50° C to 1.50° C in .5° C increments)	0° F (0.00° C)	0° F - No difference in displayed temperature and the actual room temperature. The thermostat displays up to 3°F (1.5°C) lower or higher than the actual measured temperature.
14020	Indoor Humidity Display Offset	-12% to 12% (in 1% increments)	0° F	0% - No difference in displayed humidity and the actual room humidity. The thermostat displays up to 12% lower or higher than the actual measured humidity.
15000	Dealer information	Company Phone Website Email Contractor Pro - number		Touch each individual category to enter the information. If an alert or notification appears on the screen, the customer will be shown the dealer information so they know who to contact. Enter your company's Contractor PRO account number to receive bonus points for every T10 Pro Smart thermostat you install. Your account number is an 8 digit number which includes a leading zero (example 01234567).

Wi-Fi setup

During the initial installation, after the Installer setup the thermostat will prompt you to set up Wi-Fi and guide you through the steps. if you are setting up Wi-Fi after the initial installation has already been done, follow the below steps:

1. Select the **main menu icon**

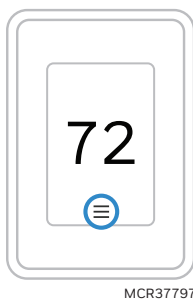

Fig. 41. Main menu icon.

2. Then select **Configuration - Wif-Fi**
3. There is a slider labeled "Enable Wi-Fi". Make sure this is set to the right.
4. Touch "Choose Network".
5. After a brief delay, the thermostat should show the available networks. Choose your home network from the list.

6. If this is a secure network, it should prompt you to "Enter Wi-Fi password". After a brief delay the display should show "Success! Your thermostat successfully connected to the network." Press the "OK" button.

NOTE: If you did not successfully connect to the network, attempt to:

7. Download the Honeywell Home app from the App store or Google Play.
8. Open the Honeywell Home app. Tap SET UP NOW as shown here to continue. Tap INSTALL A DEVICE and follow the prompts to continue. The app will walk you through the rest of the setup.

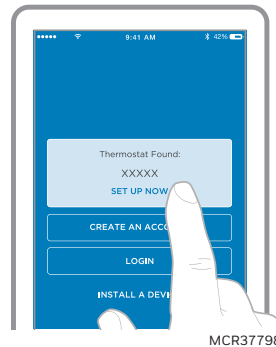

Fig. 42. Set up now.

Connect to a hidden Wi-Fi® network

1. Touch MENU, then Wi-Fi Setup.
2. Touch Other, then Select.
3. When prompted, press the screen to edit the network name.
4. Enter the network name.
Press the ▲ or ▼ buttons to change the letter or number. Press the ► button to move to the next character, or the ◀ button to move to the previous character. Use the ▲ or ▼ buttons at the bottom to change letter case. Press Done when complete.
5. Select the appropriate network security setting, then press Select.
6. Enter the Wi-Fi network password as explained above in "Connecting to Wi-Fi Network", step 6.

Unsuccessful Wi-Fi connection

If you are unsuccessful in connecting the thermostat to the Wi-Fi network, you will see a Connection Failed screen. Press ▼ button for other tips about this failed connection. Here are three specific reasons the connection might be unsuccessful.

For all Connection Failed screens, pressing Done will return to the Menu screen.

Invalid Password

The password you entered is invalid. Check that you have the right password and try again.

No IP Address

The thermostat was unable to obtain an IP address from the router. Verify the router is correctly set up to automatically assign IP addresses. This connection can take several minutes. If there is still no connection, remove the thermostat from the wallplate for 10 seconds, then snap it back into place.

No Internet Link

The thermostat connected to the Wi-Fi network but was unable to establish a connection to the internet. Check the router settings and try again. Make sure the Ethernet cable is plugged into the router and try rebooting the router if necessary.

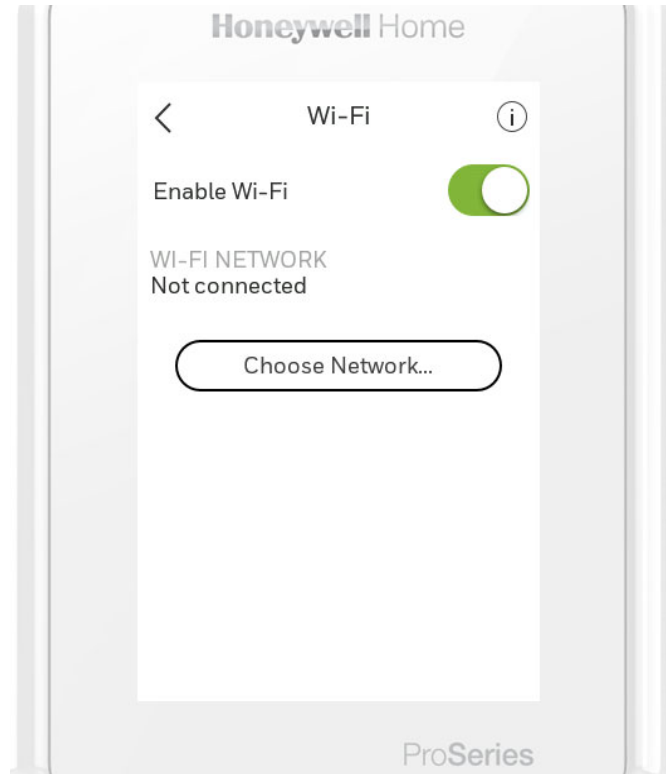

Fig. 43.

Wi-Fi setup, after initial installation

During the initial installation, after the Installer setup the thermostat will prompt you to set up Wi-Fi and guide you through the steps. If you are setting up Wi-Fi after the initial installation has already been done, follow the below steps:

1. Select the **main menu icon**
2. Then select **Configuration - Wi-Fi**
3. There is a slider labeled "Enable Wi-Fi". Make sure this is set to the right.
4. Touch "Choose Network".
5. After a brief delay, the thermostat should show the available networks. Choose your home network from the list.
6. If this is a secure network, it should prompt you to "Enter Wi-Fi password". After a brief delay the display should show "Success! Your thermostat successfully connected to the network." Press the "OK" button.

NOTE: if you did not successfully connect to the network, attempt to-

Scheduling and Geofencing

Time-based scheduling setup on thermostat-

- From Homescreen, Select Menu-Schedule.
- Select "Grouped days" if you want the same schedule for all days.
- Select "Single Days" if you want 7 day scheduling.
- Select "Schedule Options"- Create New Schedule" to get additional option for 5-2 Scheduling.

- Select “let me choose” to select the days you want grouped. (Ex: 5-1-1 schedule with M-F the same and Sat & Sun each individual).
- Once the selected days are chosen touch “Next”.
- Set the wake time by scrolling up to down by the hour, the minute, and AM or PM.
- Touch “Next”.
- If you are using RedLINK wireless indoor sensor(s). Set the Wake priority to “selected rooms” or “Active Rooms”. If “selected Rooms” is chosen you can choose the room(s) you want to use for temperature control during Wake.
- Touch “Next”.
- Set the Cool and Heat setpoints for the Wake schedule period.
- Touch “Next”.
- Set the Wake fan setting to Auto, on, or circulate. (See “Setting the Fan” on page 32 for more information.)
- Touch Next.
- If “Someone is Home All day” is selected, the thermostat will follow the same heat/Cool/Fan settings as the Wake uses for the Return and Home schedule. The thermostat will skip ahead to the sleep schedule settings. If “Someone is Home All day”, is not selected, the Away and Home settings need to be entered.
- Set the Away, Home, and Sleep settings using the same format as described for the Wake setting.
- If you had not selected all days are scheduled the same, repeat these steps for the other days or groups of days.

Schedule override

With thermostat in heat, cool, auto, or em heat mode, press the up or down arrow to change the setpoint. (if thermostat is in auto mode, you need to press “heat to” or “cool to” first). If scheduling is enabled it will say “Hold until” and show a time at the bottom of the screen. Touch this. Display says “Use current temperature, fan, and comfort priority settings until...”

Options are:

- Next Period
- A Specific Time
- Permanently
- Remove hold

Choose the appropriate option. If you chose “A Specific time”

Select the time you want to hold to.

Press “Done” to return to Home screen.

Main Menu

From Home Screen, press the menu icon at bottom of the display (3 horizontal lines). (If this is not shown at home screen, touch screen to wake display first).

Main Menu Options

System mode

(Available modes vary depending on how the thermostat was configured)

- Heat
- Off
- Cool
- Auto (see “Auto Changeover operation” on page 37)
- Em Heat (see “Em Heat and auxiliary heat operation” on page 37)

Fan

(Fan setting not available for all system types)

- Auto (Fan only runs with a call for heat or cool, or if set to run with Hum, dehum, or vent call)
- On (fan runs continuous)
- Circulate (fan runs randomly approx. 33% of the time)

Priority

If wireless indoor temperature/humidity/motion sensors are used, select which sensors are used for temperature control. Can choose active sensor (ones detecting motion) or manually select which sensors to use.

Schedule

- Create new schedule – (Set a time-based schedule)
- Disable schedule
- Reset to default Schedule

NOTE: To enable geofencing, use the Honeywell Home app.

Management:

Devices & Sensors

- View the temperature and humidity reading from individual sensors
- Identify a wireless indoor sensor
- Add a new wireless indoor sensor
- Remove a wireless indoor sensor

Thermostat information

- Mac Address
- IP Address
- Date Code
- Model Number
- Build Date
- Collection Version
- Wi-Fi Bootloader Version
- Wi-Fi Application Version
- RedLINK Application Version

Equipment Status

- System mode
- Heat stages (on or off)
- Cool stages (on or off)
- Fan on or off
- IAQ (Hum, Dehum, or Vent) on or off

Dealer Information

- Model number
- Date code
- Dealer company name and contact information if provided by installer (See “Installer Options Menu” on page 31).

Configuration

- Wi-Fi
- Security
- Preferences
- Installer Options (See “Installer Options Menu” on page 31)

Installer Options

To access the Installer options menu

1. Touch the menu icon (3 horizontal lines at bottom of display)
2. Scroll down and touch “Thermostat Information”.

3. Write down the date code from that screen. The touch the left arrow at top of display to go to previous screen.
4. Scroll down until “installer Options” is shown. Touch “installer options” and enter date code.

How to find more options

1. Touch the menu button.
2. Scroll up and down for more options.

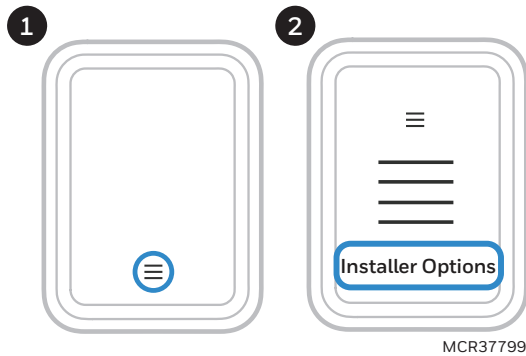

Fig. 44.

Installer Options Menu

Installer setup

Setup thermostat. See Table 5 beginning on page 17.

Installer Test

- Turn on or off heat stages
- Turn on or off cool stages,
- Turn on or off em heat stage,
- Turn on or off IAQ equipment

Dealer Information Setup

Enter installer company name, phone number, website, and email. That way if customer gets an alert or reminder the contractor contact information can be displayed.

Devices and Sensors

- View the thermostat and any RedLINK accessories from this screen.
- Add a RedLINK accessory.
- Identify a wireless sensor. (The thermostat will prompt you to remove the cover from the sensor you want to identify and press the button on the sensor. The thermostat will display the name of the sensor (the room name you selected when linking the sensor to the thermostat).

Thermostat Information

- Mac Address
- Date Code
- Model number
- Build date
- Collection Version
- Bootloader Version
- Application Version
- Wi-Fi Bootloader Version
- Wi-Fi Application Version
- RedLINK Application Version

Reset

- Reset Schedule
- Delete all sensors
- Factory Reset
- Reset Wi-Fi?

Getting the most from the T10 Smart Thermostat

Prioritize Rooms

Prioritize a specific room or multiple rooms, or let comfort follow your move using built-in motion detection.

Control on the Go

Adjust your thermostat from anywhere using your tablet or smartphone.

Save Energy

With geofencing, you can save money on the most expensive part of your energy bill while you’re away.

Simple Installation

The thermostat automatically programs itself. Just answer a few simple questions and you’ll be up and running in no time.

Whole-Home Range

With a 200-foot range, 20 sensors with temperature, humidity, and occupancy detection can connect to your thermostat from throughout your home.

Know Your Home Is Safe

Get customizable alerts on your mobile device when the basement is so cold a pipe could burst, or if the baby’s room is getting too hot.

Using your thermostat

The screen will wake up by pressing the center area of the displayed temperature.

Current Priority

Displays the type of priority and number of rooms being prioritized.

Indoor Temperature

Displays the current indoor temperature.

Menu

Contains features such as mode, fan, schedule, priority, and other thermostat settings.

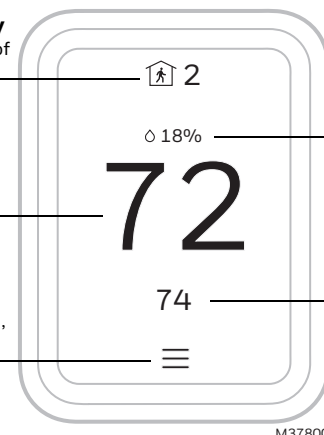

Indoor Humidity
Displays the current indoor humidity

Desired Temperature
Displays the desired temperature.

Fig. 45.

Setting the Time/Date

When the thermostat is linked to the home Wi-Fi router and registered to an account using the Honeywell Home app, the date and time will update automatically.

If not using Wi-Fi you can set the time/date as follows:

1. Touch menu.
2. Scroll down and select “Preferences”.
3. Select “Date and Time”.
4. Date and time information are displayed.

Set date

- If the date shown is incorrect, touch “date”.
- Scroll up or down on the left of the display until the correct month is in the middle of screen.
- Scroll up or down on the center of the display until the correct day is in the middle of screen.
- Scroll up or down on the right of the display until the correct year is in the middle of screen.
- Touch “Done”.

Set time

- If the time shown is incorrect, touch “time”.
- Scroll up or down on the left of the display until the current hour is in the middle of screen.
- Scroll up or down on the center of the display until the current minutes are in the middle of screen.
- Scroll up or down on the right of the display until the correct am or pm is in the middle of screen.
- Touch “Done”.

Setting the Fan

NOTE: Fan setting not available for all system types.

Touch menu

Touch Fan

Choose on, auto, or circulate.

Auto setting only runs the fan with the heating or cooling system.*

On setting runs the fan continuously.

Circ setting runs the fan approx 33% of the time to ensure air circulation.

* The fan may also run with the humidifier, humidifier, or ventilator depending on how the thermostat was configured.

Programming the Fan

You can set the fan to on, auto, or circ for each program when using time-based scheduling.

Setting the System mode

Touch menu

Touch System mode

Touch desired option

- Heat: Controls only the heating system.
- Cool: Controls only the cooling system.
- Off: Heating/cooling systems are off.
- Auto: Selects heating or cooling depending on the indoor temperature.
- Em Heat (heat pumps with aux. heat): Controls auxiliary/emergency heat. Compressor is locked out.

Touch Done to save and exit.

NOTE: The Auto and Em Heat system settings may not appear, depending on how your thermostat was installed.

Using Priority

Priority creates an average temperature in your home based on specific rooms. This allows you to prioritize comfort where you want it.

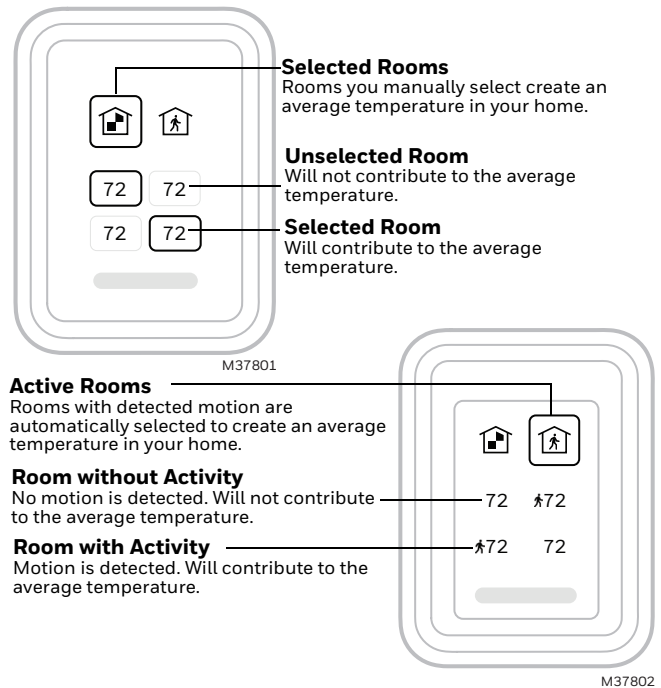

Fig. 46.

Selecting sensors

The temperature reading displayed on the home screen is from the sensor or sensors that are being used for temperature control. You can change which sensors are being used for control by selecting menu-priority. From the home screen, touch the menu icon at the bottom of the display and select “Priority”.

Priority screen

Selected rooms

When set to “selected rooms” you may select one or more rooms to read the wireless indoor sensor information from.

When multiple sensors are selected, the temperature is averaged.

Active rooms

When set to “Active rooms” the thermostat controls temperature based on the reading from the indoor sensors that detect motion.

Alerts and notifications

1. The red dot above the **Menu** icon indicates an active alert or notification. Touch the Menu icon to view active Alerts & Notifications.
2. Touch **Notifications** to open this menu.
3. Touch the alert message to see more information about the alert.

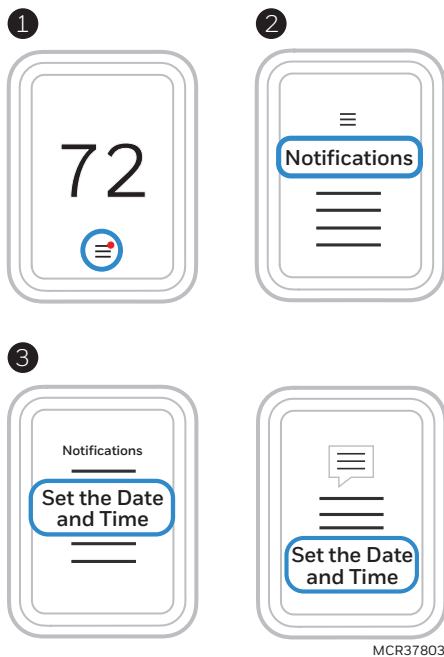

Fig. 47.

When there is an active alert or notification, you must select the notification banner and acknowledge the message before you are allowed to access the menu icon.

IAQ REMINDERS

You can set up IAQ reminders in the thermostat to remind users when filters, pads, bulbs, etc. need cleaning or replacement. The available reminders vary based on the ISU settings. For example, if the thermostat is configured to control a flow through humidifier, it will have the humidifier pad reminder but not the humidifier tank reminder:

- Air Filter 1
- Air Filter 2
- Electronic Air Cleaner Pre-Filter
- Electronic Air Cleaner Post-Filter
- Humidifier Tank/Water Filter
- Humidifier Pad
- Dehumidifier Filter
- Ventilator Core
- Ventilator Filter
- UV Bulb 1
- UV Bulb 2

Reminders that are displayed under preferences will change based on the IAQ equipment installed. Reminders for equipment that is already set up can be set using the steps below. Reminders for IAQ equipment that is not yet set up must be turned on from the installer setup.

NOTE: Air Filter, Humidifier Pad, Dehumidifier Filter, and Ventilator Filter are displayed under Preferences even if they have not been set up. Humidifier Pad is not displayed if a steam humidifier has been installed.

To access or adjust the reminder settings

- Select the menu icon.
- Scroll down and select “preferences”.
- Select the reminder you want to set from the list (shown above).
- Press ^ or v to set the timer length. Ranges, increments, and units will change based on the reminder.
- Press Done to save the reminder.
- Press Reset Timer when you have completed the recommended maintenance or you can extend the timer setting to turn off the alert and remind you later to do the recommended maintenance.
- Repeat these steps for all reminders you want to set

NOTE: When set for run time days, the thermostat tracks the amount of time the fan has run and compares that time against the number of run time days selected. Fan run time is counted when there is a call for forced air heating, cooling, or fan.

Setting Preferences

Preference menu options let you select how the thermostat displays information or responds to certain situations.

To access the Preferences menu:

- Touch menu
- Scroll down and select “preferences”.
- Select an option and follow prompts:
- Display
 - Temperature units (Fahrenheit or Celsius)
 - Language (English French or Spanish)
 - Inactive backlight setting (0% to 100%)
 - Inactive Sleep backlight setting (0% to 100% and inactive sleep time settings. Note: these can be set different than the schedule sleep times)
 - Indoor display offsets (temperature and humidity)
 - Clean screen (allows you 30 seconds to clean display without accidentally adjusting a setting)
- Date and Time
 - Set date
 - Set time
 - Set to 12 or 24 hour clock
 - Set for daylight savings time
- Reminders (these vary based on ISU settings)
 - Air Filter 1
 - Air Filter 2
 - Electronic Air Cleaner Pre-Filter
 - Electronic Air Cleaner Post-Filter
 - Humidifier Tank/Water Filter
 - Humidifier Pad
 - Dehumidifier Filter
 - Ventilator Core
 - Ventilator Filter
 - UV Bulb 1
 - UV Bulb 2
- Adaptive recovery
 - On or Off

Touch Done to save your settings.

Indoor Air Quality control

Humidification

The thermostat reads the indoor humidity level and allows the user to set a humidification setting with or without window protection. The thermostat can be set up to control a humidifier in any system mode in the Installer Setup (ISU 8060).

Window Protection

Window Protection limits the amount of humidity to prevent frost or condensation on windows. Window Protection (ISU 8050) requires either an outdoor sensor or use of Internet weather (Outdoor temperature setting In ISU chart on page 17).

The thermostat prevents frost or condensation on windows by not allowing the humidifier to run above a certain level. To prevent frost or condensation, the thermostat may turn off the humidifier before the humidity setting is reached.

If Window protection is enabled ((ISU 8050), you can adjust this setting by pressing MENU, then scroll down and select Humidification-Options-Window Protection Level. Window Protection is set on a scale from 1-10. A setting of "1" represents poorly insulated windows and a setting of "10" represents well insulated windows. A lower number automatically reduces the humidity to help prevent frost or condensation on your windows. Use a higher number if indoor air seems too dry. To prevent frost/condensation on your windows during cold outdoor temperatures, poorly insulated windows require a lower Window Protection setting, which will limit how much your humidifier can run. After you set the Window Protection setting, check for frost/condensation on your windows in the morning. If frost/condensation is present, adjust the Window Protection setting to the next lowest number and check for frost/condensation on your windows the next morning.

Continue to adjust the Window Protection setting to a lower number until frost/condensation is no longer present. If Window Protection is turned Off, the thermostat controls the humidity level to the user's desired humidity setting.

Frost or condensation may appear on windows.

Set up Humidification

1. Select the Humidifier Type at ISU 8000 (see page 23). NOTE: Based on the humidifier type you select, the thermostat defaults to the most commonly used settings for that humidifier type. For example, a Bypass or Fan Powered humidifier will default ISU 8070 to "Hum when Heat is On." A Steam humidifier will default ISU 8070 to "Tstat controls Fan."
2. Set Window Protection setting (page 24). NOTE: Outdoor sensor temperature (Sensor or Internet weather) is required for Window Protection. See ISU for outdoor temperature on page 17.
3. Select the system mode(s) to allow humidification. ISU 8060 on page 24. Options are Heat and off. NOTE: Heat includes Heat, Emergency Heat and Auto. If the system is in Auto mode, the thermostat will allow humidification if the last call was for heat.
4. Select from one of the Humidification Control Options (ISU 8070 on page 24).

- Hum when Heat is On
 - The thermostat turns on the humidifier only if the heat is currently running and humidification is needed.
- Hum when Fan is On
 - The thermostat turns on the humidifier only if the fan is currently running and humidification is needed.
- Tstat Controls Fan
 - The thermostat turns on the humidifier and the fan when humidification is needed.
- Hum Controls Fan
 - The thermostat turns on the humidifier when humidification is needed and the humidifier controls the fan.

Control Humidification Level

1. Touch MENU and select Humidification. Touch ^ or v to select humidity level.
2. Touch Done to save your settings. Touch Cancel to ignore changes.
3. If frost or condensation appears on the windows, press MENU, scroll down and select "options". Then select "Window Protection Level".

Window Protection is set on a scale from 1-10. A setting of 1 represents poorly insulated windows and a setting of 10 represents well insulated windows. A lower number automatically reduces the humidity to help prevent frost or condensation on your windows. Use a higher number if indoor air seems too dry. To prevent frost/condensation on your windows during cold outdoor temperatures, poorly insulated windows require a lower Window Protection setting, which will limit how much your humidifier can run.

4. After you set the Window Protection setting, check for frost/condensation on your windows in the morning. If frost/condensation is present, adjust the Window Protection setting to the next lowest number and check for frost/condensation on your windows the next morning. Continue to adjust the Window Protection setting to a lower number until frost/condensation is no longer present.

NOTE: The Window Protection option is only available if a wired outdoor sensor or Internet is used to provide outdoor temperature. See ISU setting "Outdoor Temperature" on page 17.

Dehumidification

The thermostat reads the indoor humidity level and allows the user to set a dehumidification setting. The thermostat controls the humidity level using the cooling system or a whole house dehumidifier.

Dehumidification using the Cooling System

When set for A/C with Low Speed Fan or A/C with High Speed Fan, an overcooling limit can be set from 0 °F to 3 °F (ISU 9070). The thermostat uses the cooling system to reduce humidity by lowering the temperature up to 3° F below the current cool setpoint until the desired humidity level is reached. If set for A/C with Low Speed Fan, configure U contacts as normally open or normally closed (ISU 9050) and wire to the Low Speed Fan terminal on the equipment. For example, if the U contacts are normally

closed, they will open when the thermostat calls for dehumidification. See “Whole House humidifier, dehumidifier, or ventilator wiring” Fig. 26 to Fig. 29.

If humidification and dehumidification are both setup to operate in the system mode (Off), the thermostat will automatically enforce a 15% deadband between the humidification and dehumidification settings. The thermostat will automatically switch between humidification and dehumidification to maintain the desired humidity level.

Dehumidification using A/C with Low Speed Fan, A/C with High Speed Fan, has the following methods of dehumidification control (ISU 9080):

Dehumidification overcooling limit (ISU 9070):

This option uses the cooling system to lower the temperature up to 5° F below the current cool setpoint until the desired humidity is reached. The Dehum Over Cooling Limit range is from 1° to 5° F.

NOTE: The thermostat will not lower the fan speed when the second stage of cooling is on.

Set up Dehumidification With Cooling System

Some screens shown in this section may not appear on the thermostat, depending on how you set up dehumidification.

1. Select the Dehumidification Equipment in ISU 9000. See page 24.
2. Select whether the U terminals are Normally Open or Normally Closed. See page 25.
- Normally Open – contacts are normally open and will close during a call for dehumidification
- Normally Closed – contacts are normally closed and will open during a call for dehumidification.
3. Set the Overcooling Limit. See page 25. Options:
 - 0 °F to 3 °F (A/C with Low Speed Fan)
 - 1 °F to 3 °F (A/C with High Speed Fan)

Dehumidification using a Whole House Dehumidifier

The Whole House Dehumidifier option requires a dedicated unit for dehumidification. The thermostat can be set to control dehumidification in all modes (Heat, Off, Cool [ISU 9120]). Set up Dehumidification With Whole House Dehumidifier (Some screens shown in this section may not appear on the thermostat, depending on how you set up dehumidification.)

1. Select the Dehumidification Equipment in ISU 9000. See page 24.
2. Select the system mode(s) to allow dehumidification ISU 9120. See page 25.

NOTE: Heat includes Heat, Emergency Heat and Auto. If the system is in Auto mode, the thermostat will allow dehumidification if the last call was for heat.

Cool includes Cool and Auto. If the system is in Auto mode, the thermostat will allow dehumidification if the last call was for cool.

3. Set Dehumidifier Fan Control settings ISU 9130. See page 25.

- Tstat Controls Fan Thermostat turns on the dehumidifier and the fan when dehumidification is needed.
- Equip Controls Fan Thermostat turns on the dehumidifier when dehumidification is needed. The fan is controlled by the equipment.
- 4. Set the desired lockout option. See ISU 9140 on page 25.

Control Dehumidification Level

1. Touch MENU and select Dehumidification.
2. Touch ^ or v to select dehumidity level.
3. Touch options if you want to enable/disable the dehumidifier. When disabled, the display will show off when viewing the dehumidifier setting screen.
4. Touch Done to save your settings.

NOTE: If your air conditioner is used to control humidity, the temperature may drop up to 3° F below your temperature setting until humidity reaches the desired level.

NOTE: If humidification and dehumidification are setup to operate in the same system mode (Off) the thermostat will automatically enforce a 15% deadband between the humidification and dehumidification settings. The thermostat will automatically switch between humidification and dehumidification to maintain the desired humidity level.

Dehumidification using the Cooling System

Dehumidification using A/C with Low Speed Fan, A/C with High Speed Fan, has the following methods of dehumidification control (ISU 9080):

Cooling Droop (ISU 9080): This option uses the cooling system to lower the temperature up to 3° F below the current cool setpoint until the desired humidity is reached. The Dehum Over Cooling Limit range is from 0° to 3° F for dehum with low speed fan or 1° to 3° F for dehum with high speed fan.

Ventilation

The thermostat can be set for the following ventilation types: (ISU 10000)

- ERV/HRV
- Passive (Fan Only)
- Fresh Air Damper

Ventilation Control Methods (ISU 10050)

Ventilation can be setup to meet either ASHRAE or Percent On Time settings. To meet these settings, the thermostat will ventilate during calls for heat, cool, and fan. If the required ventilation has not been achieved for ASHRAE or Percent On Time, the thermostat will force the ventilation equipment on.

ASHRAE

The thermostat operates ventilation equipment to meet the ASHRAE 62.2 ventilation standard based on CFM, number of bedrooms, and square footage of the house. ASHRAE 62.2 can only be met if the ventilation equipment is running. If the ventilation equipment is off for any

reason (outdoor ventilation lockouts, set up to turn Off during Sleep period, turned off by user, etc.), ASHRAE 62.2 is not met during those times. See ISU 1012 to select a Ventilation Priority.

Percent On Time

The thermostat operates ventilation equipment based on a percentage entered in the installer setup (ISU 1012). For example if Percent On Time is set to 50%, the ventilation equipment will run at random times during a 1 hour period until it reaches a 50% run time (approximately 30 minutes). Default setting is 30%. Range is 10% to 100% in 10% increments.

Ventilation Fan Control (ISU 10060)

- Tstat Controls Fan
 - The thermostat turns on the ventilator and the fan when ventilation is needed.
- Equip Controls Fan
 - The thermostat turns on the ventilator when ventilation is needed. The fan is controlled by the equipment.

Ventilation Priority (ISU 10125)

Lockouts are Priority

The thermostat places a priority on lockouts versus the ASHRAE 62.2 ventilation standard. The thermostat will not run ventilation during the following lockout conditions (if configured) unless you manually call for ventilation:

- Lockout Ventilation during Outdoor Conditions (ISU 10130)
- Lockout Ventilation during “Sleep” program periods. Note: This option is set by the user on the Ventilation screen. From Home press menu-ventilation-options-disable during sleep.

ASHRAE is Priority

ASHRAE requires additional ventilation following a long off cycle. The thermostat meets the ASHRAE 62.2 ventilation standard by running additional ventilation when outdoor conditions are favorable. If ASHRAE cannot be met when outdoor conditions are favorable, the thermostat will override the outdoor lockouts and run ventilation. When using this option, it is recommended to increase the rate (CFM) of the ventilation equipment to meet the ASHRAE 62.2 ventilation standard in a shorter run time.

NOTE: The ability to lockout ventilation during the “Sleep” program periods is not an option when you select ASHRAE is Priority.

Ventilation – Outdoor Condition Lockouts (ISU 10130)

Ventilation will not operate when outdoor conditions exceed the lockout settings unless you manually call for ventilation or Ventilation Priority (ISU 10125) is set to ASHRAE is Priority and ventilation is needed to meet ASHRAE. Lockouts can prevent ventilation during extreme weather conditions to keep humid, hot, and cold air out of the home.

NOTE: This feature requires a wired sensor for outdoor temperature limits, or Internet connection for temperature and humidity lockouts.

Options are:

- Ventilation Low Temperature Lockout Setpoint (Off, -20° to 40° F)

- Ventilation High Temperature Lockout Setpoint (Off, 80° to 110° F)
- Ventilation High Dewpoint Lockout Setpoint (Off, 65° to 85° F)

Refer to the information below if you need assistance setting the High Dewpoint Lockout.

- Higher than 80: Extremely uncomfortable
- 75 to 80: Very uncomfortable
- 70 to 74: Quite uncomfortable
- 65 to 69: Somewhat uncomfortable

Control Ventilation Level

1. Touch MENU, and select Ventilation. You can check or change the ventilation mode.

Mode:

- Auto: Ventilation runs as programmed by the installer.
- Off: Ventilation remains off unless turned on using the timer.
- On: Ventilation is always on.

The display will show whether the ventilator is currently running under “status”. To temporarily turn the ventilator on, use the up arrow to set the number of minutes you want the ventilator to run (0-180 minutes). To cancel a temporary setting, press “Cancel Timed Ventilation”. Note: This setting is not available when ventilator is set to “on”.

2. Touch Done to save your settings. Touch Cancel to ignore changes.

Lockout During Sleep:

Under the ventilation menu, touch “options”. Select or deselect “disable during Sleep”. Touch the back arrow in upper left of display to return to previous screen.

Cleaning the Thermostat Screen

When you select the Clean Screen option, the screen is locked to prevent accidental changes to the thermostat while you clean the screen.

1. Touch MENU.
2. Scroll down and select “Preferences”.
3. Select “Display”.
4. Select “Clean Screen”
A prompt asks if you want to clean the screen for 30 seconds.
5. Touch Yes. A countdown timer displays elapsed time until the screen is reactivated.

NOTE: Do NOT spray any liquid directly on the thermostat. Spray liquids onto cloth, then use the damp cloth to clean the screen. Use water or household glass cleaner. Avoid abrasive cleansers.

Adjusting Security Settings

You can adjust security options to prevent unauthorized changes to system settings.

1. Touch MENU.
2. Scroll down and select Security.
3. Select “Change lock mode” or “create password”.

Lock mode options

- Unlocked: Full access allowed.
- Partially locked: Only temperature can be changed.
- Fully locked: No access allowed.

NOTE: If you choose to create a password for additional security, write it down for reference.

Dealer Information

This can be viewed by the homeowner when an alert or reminder message appears on the thermostat display. Entering Dealer Information

1. Touch MENU.
2. Scroll down and select Dealer Information. If this information has not previously been entered, note the date code from this screen.
3. Touch the back arrow in upper left of display.
4. Select "Installer Options".
5. Enter date code .
6. Select "Dealer Information Setup.
7. Click on each of the categories to enter the dealer information.
 - Company
 - Phone
 - Website
 - Email

Viewing Dealer Information

Check dealer information if you need to contact your installer for maintenance, repairs, or upgrades.

1. Touch MENU.
2. Scroll down and select Dealer Information

NOTE: This menu option will only appear if the contractor had entered this information.

Auto Changeover operation

Auto changeover is available if the thermostat is configured for at least 1 heat stage and 1 cool stage and ISU 3000 is set to "Auto".

When configured this way, you can select "Auto" as one of the options under "System mode".

ISU 3015 is the auto changeover differential setting. It can be set from 0-3 °F. (0-2.5 °C) to This is the minimum number of degrees needed between the heat and the cool setpoints when the thermostat is in auto changeover mode. When in auto mode, the customer can always set the heat and cool setpoint to the same temperature, regardless of the differential setting although most customer prefer to have a cool setpoint that is at least 3 degrees above the heat setpoint. When 0 is selected, we enforce a 1.5°F differential behind the scenes to ensure the heat doesn't come on after cooling shuts off or vice-versa.

The differential is the minimum number of degrees the temperature needs to rise or fall before switching from heat to cool while in auto changeover mode. Example: If heat and cool were both set for 70, and heat had been used last, the temperature would need to rise at least 3 degrees above the heat setpoint before the thermostat would turn on cooling. Then it would cycle cooling on and off to maintain setpoint and the temp would need to drop at least 3 degrees below the cool setpoint before heat could come on.

If the AC is used for dehumidification then we enforce an additional temp drop below the overcooling amount, (ISU 9070) prior to switching back to heat.

Em Heat and auxiliary heat operation**Auxiliary heat:**

- Auxiliary heat runs as backup to the heat pump. It runs with the heat pump when:
- The thermostat is set to heat mode.
- The backup heat is set to electric (ISU 2180).
- Load conditions determine backup heat is needed.

The heat pump could be locked out when in heat mode by the balance point setting (ISU 3120) or if the backup heat is gas or oil and backup heat differential (ISU 3090) or upstage timer (ISU 3110) are used.

Emergency heat:

Emergency heat runs when you manually switch the thermostat to the em heat mode. When the thermostat is in emergency heat mode, the heat pump is locked out.

Emergency heat mode is only available when the thermostat is configured for a heat pump (ISU 2000) and Backup heat stages is set to 1 (ISU 2071).

From home screen touch the menu icon and then "system Mode". You can set the thermostat to heat, off, cool, emergency heat, or auto (auto only available if ISU 3000 is set to auto).

When the thermostat is set to em heat mode, the heat pump is locked out and the backup heat is used to maintain the heat setpoint.

If ISU 2175 is set to "Drive aux and E together", then with a call for emergency heat or auxiliary heat, both E and AUX terminals are energized. Typically the backup heat is wired to Aux and E is unused when set this way.

If ISU 2175 is set to "Aux and E independent", then with a call for emergency heat, the E terminal is energized and the aux terminal is not. The wire to Aux controls a heat source that runs as backup heat to the heat pump when the mode is set to "heat". The wire to E controls a heat source that runs independent of the heatpump when mode is set to em heat. In most cases, the heat pump uses the same heat source for auxiliary heat and em heat.

Dual fuel systems (Heat pump with gas or oil furnace backup) cannot run the heat pump and furnace at the same time.

Advanced Features**Adaptive Intelligent Recovery**

Over time, the T10 thermostat "learns" how long it takes your system to reach your programmed temperature setting.

The thermostat turns on the heating/cooling system early and assures that the programmed temperature setting is reached at the programmed time regardless of weather conditions. For example, if the Wake program period is set to 6:00 am with a heat setting of 70 degrees, the heat will turn on before 6:00 am, so the temperature is 70 degrees at 6:00 am. The thermostat displays "In Recovery" when it turns the system on early.

Adaptive Intelligent Recovery® calculates the recovery ramp based on how far the room temperature is away from the temperature setting, previous equipment performance

and weather history, allowing the thermostat to start recovery at the optimal time so it can reach the programmed temperature setting at the programmed time. The T10 thermostat uses two recovery ramps when setup to control a heat pump system. One ramp for the compressor and one ramp for the auxiliary heat. Once the room temperature intersects the compressor ramp, the compressor turns on until the setpoint is reached. If the room temperature does not rise quickly enough and intersects the second ramp, the auxiliary heat turns on. It takes about one week for the thermostat to adjust to weather conditions, equipment performance and construction of the home. If the temperature setting is reached too early or too late, the ramp is adjusted for the next day's recovery. See Fig. 48.

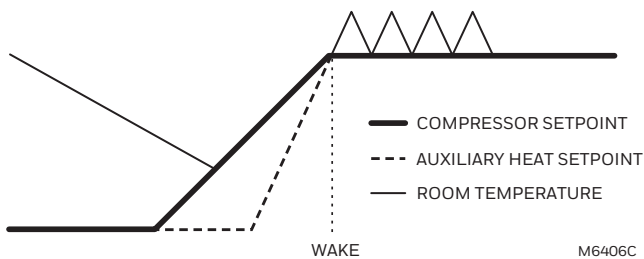

Fig. 48.

Compressor Protection

The thermostat keeps the compressor off for a few minutes before restarting, to prevent equipment damage. During this "off" time, the message "Wait" is displayed on screen.

P + I Control

A conventional mechanical or electronic thermostat does not control temperature precisely at setpoint. Typically there is an offset (droop) in the control point as the system load changes. Many factors contribute to offset including the switch differential, thermal lag, overshoot, cycle rates and system load.

The T10 thermostat however, works much differently than a conventional mechanical or electronic Thermostat when droop is set to comfort. Droop is always set to comfort and not adjustable when controlling a 2 stage furnace or 2 stage heat pump without aux heat. The proprietary algorithm in the thermostat eliminates the factors causing offset (droop). This makes temperature control more accurate than the conventional mechanical or electronic thermostat. The temperature control algorithm is called proportional plus integral (P + I) control.

The thermostat sensor or indoor sensor senses the current space temperature. The proportional error is calculated by comparing the sensed temperature to the setpoint temperature. The deviation from the setpoint is the proportional error.

The thermostat also determines integral error, which is a deviation based on the length of error time (how long the sensed room temperature has been away from the setpoint temperature). The sum of the two errors is the (P + I) error.

The cycle rate used to reach and maintain the setpoint temperature is computed using the P + I control algorithm. The addition of the integral error is what differentiates the thermostat from many other mechanical and electronic thermostats.

Heat Differential

For stage 2 of conventional systems or 2 stage heat-pump without aux heat

The thermostat will use the stage of heating as needed to keep the indoor temperature within 1 °F (0.5 °C) degree of the setpoint. The thermostat turns on stage 2 when the capacity on stage 1 reaches 90%.

Heat pumps with electric aux heat when droop is set to "comfort"

The thermostat will use the stage of heating as needed to keep the indoor temperature within 1 °F (0.5 °C) degree of the setpoint. The thermostat turns on Aux heat when the capacity on highest compressor stage has reaches 90%.

Heat pumps with electric aux heat when droop is set to 2°F or higher

(2 °F to 15 °F adjustable)

If the indoor temperature drops to the droop amount while the highest compressor stage is running the thermostat will continue to run the heatpump stages and also energize the Aux heat.

For example, if the Backup Heat Droop is set to 2 °F (1.0 °C), the indoor temperature must drop 2 °F (1.0 °C) below the setpoint while the previous stage is running before the backup heat turns on. Raising setpoint manually or by a schedule change does not cause droop to run the backup heat. When droop is set to other than comfort, the upstage timer setting is also available.

Dual fuel Heat pumps with gas or oil backup heat

If thermostat is configured to control dual fuel, the droop cannot be set to comfort. It will default to 2 °F and can be adjusted from 2 °F to 15 °F.

If the indoor temperature drops to the droop amount while the highest compressor stage is running the thermostat will end the call for the heatpump stages and run the fossil fuel heat stage.

For example, if the Backup Heat Droop is set to 2 °F (1.0 °C), the indoor temperature must drop 2 °F (1.0 °C) below the setpoint while highest heatpump stage is running before the thermostat will shut down the heat pump and run the fossil fuel heat.

Raising setpoint manually or by a schedule change does not cause droop to run the backup heat. When droop is set to other than comfort, the upstage timer setting is also available.

Upstage Timer

The upstage timer setting is only available when:

The thermostat is configured for a heat pump with an aux heat stage (electric or fossil fuel).

The droop setting is set to a setting other than "Comfort" (2 °F to 15 °F).

Backup Heat Upstage Timer options are Off, 30 minutes to 16 hours. Default is Off.

The upstage timer allows* the aux heat to run when the highest heat pump stage has run for longer than the timer setting during a steady state condition. Steady state means the thermostat is cycling to maintain setpoint.

Manually raising the setpoint or a scheduled setpoint change will not trigger the upstage timer. In those conditions the thermostat will not use backup heat unless a different condition triggers the thermostat to run the backup heat (Droop, balance point, or manually switching the thermostat to em heat mode).

*Droop and upstage timer are designed to restrict the auxiliary heat for customers who are energy conscious. The aux heat does not necessarily run after the timer has expired even in a steady state condition. Once the timer expires in steady state the thermostat calculates whether or not to run the aux heat based on the load capacity of the highest heat pump stage.

If the heat pump struggles to maintain setpoint, we would suggest one of the following steps:

1. Verify the heat pump is operating as expected.
2. Set a balance point. If a balance point is already used but the heatpump cannot handle the load even when operating correctly, the installer may need to raise this setting.
3. For heat pump with electric backup heat, set the droop to "Comfort", this uses the backup heat more aggressively."

PROGRAMMED RECOVERY

If the primary heat is making progress as expected, backup heat will not be used to reach the setpoint of the next program period. Backup heat is always restricted during a programmed recovery when the Adaptive Intelligent Recovery feature is used. See note below.

NOTE: During a programmed recovery (or when the temperature setpoint is changed by the user), the thermostat waits to turn on the backup heat depending on system performance, load conditions and how many degrees the temperature setpoint is changed. Backup heat will be used ONLY when the temperature is not rising quickly enough to reach the setpoint in a reasonable time. Upstage timer for heat pump with aux heat applications is only used in steady state (cycling to maintain setpoint). The thermostat will not run the aux heat during a programmed recovery unless one of the following conditions occurs:

1. Droop is set for comfort and thermostat calculates that the heatpump cannot effectively handle the load conditions.
2. Droop is set to 2 °F to 15 °F and indoor temperature drops while the highest stage of heatpump is running.
3. Outdoor temperature drops below the balance point setting (if used).
4. Thermostat is manually switched to em heat mode.

Finish with high Heat stage and/or Finish with high cool stage

These settings allow the installer to keep the high stage of the equipment running until the desired setpoint is reached. This setting is recommended for Geothermal Heat Pumps to allow the loop to rest.

When set to no (default), the thermostat cycles the stages based on load conditions and the cycle rate setting for these stages.

"Finish with High cool Stage" is ISU 3020 "Finish with High stage Stage," is ISU 3021. Set to Yes to turn on these features.

Default is No. See ISU settings on page 19.

HEAT PUMP AND BACKUP HEAT OPERATION

Heat pump with outdoor temperature lockouts

Outdoor temperature lockouts are optional. See Installer Setup options (ISU 312).

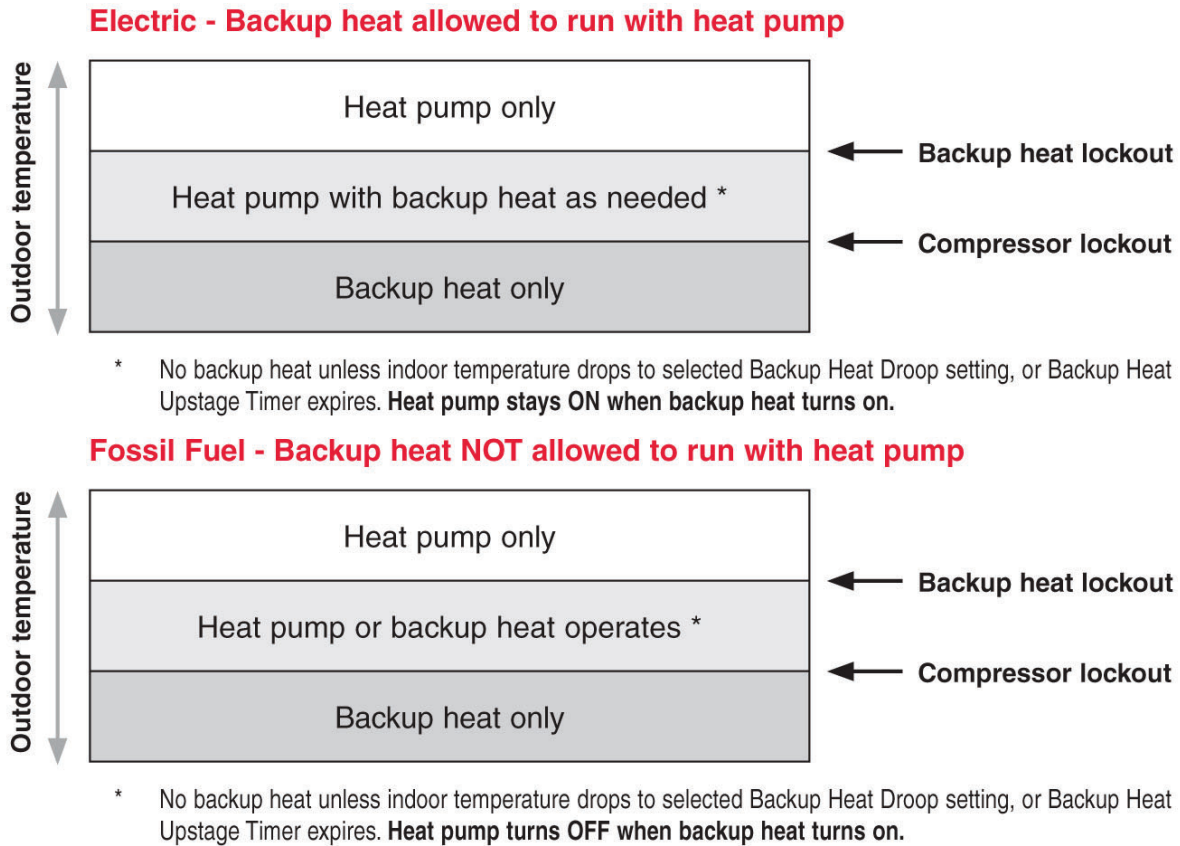

Fig. 49.

Battery Replacement (indoor sensor)

The T10 thermostat does not use any batteries. It is powered by 24 volts from the HVAC transformer using the C (common) wire.

Battery level indicators

- Good: Status light flashes green for 5 seconds.
- Low: Status light flashes red for 5 seconds. Use fresh batteries.
Battery level indicators (during use)
- Good: Status light remains off.
- Low: Battery power will be depleted in about 2 months. Thermostat displays Low Battery warning. Status light remains off.
- Critical: Battery power will be depleted in about 2–3 weeks. Status light flashes red.

Batteries

Replace batteries in your indoor sensor when a warning appears on the thermostat screen, about 60 days before batteries are depleted.

When the sensor status light begins flashing red, battery power is critically low and will be depleted within 2–3 weeks. During normal operation, the status light remains off.

To replace the batteries:

1. Remove the sensor from wallplate.
2. Install 2 fresh AAA alkaline batteries. If the status light flashes green, batteries are good; if it flashes red, you must use fresh batteries.
3. Attach sensor to wallplate.

The sensor will restore communication with the thermostat a few seconds after new batteries are installed.

Troubleshooting

If you have difficulty with your thermostat, please try the following suggestions. Most problems can be corrected quickly and easily.

Display is blank

- Check circuit breaker and reset if necessary.
- Make sure power switch for heating & cooling system is on.
- Make sure furnace door is closed securely.
- Make sure the C wire is connected.

Heating or cooling system does not respond

- Press **Menu > System Mode > Heat > Done** to set the system to Heat mode. Make sure the desired temperature is higher than the indoor temperature.
- Press **Menu > System Mode > Cool > Done** to set the system to Cool mode. Make sure the desired temperature is lower than the indoor temperature.
- Check circuit breaker and reset if necessary.
- Make sure power switch for heating & cooling system is on.
- Make sure furnace door is closed securely.
- Wait 5 minutes for the system to respond.

Temperature settings do not change

1. Verify the thermostat is set to the correct mode. Press menu-mode to change mode setting.
2. If the display indicates “screen locked” when you press the up or down arrow, you can unlock the screen by selecting menu-security settings.

3. The thermostat may be preventing you from changing the set-point above or below a certain setting because of installer configured minimum and maximum settings. See the ISU settings for 4100 on page 22.

Default minimum and maximum settings-

- Heat: 40 °F to 90 °F (4.5 °C to 32.0 °C)
- Cool: 50 °F to 99 °F (10.0 °C to 37.0 °C)

Aux heat runs in cooling

- For heat pump systems, verify there is not a wire attached to W on the UWP.

Cool runs with a call for heat

- For heat pump systems, verify there is not a wire attached to W on the UWP.

Cooling runs below set-point:

Cool should never run unless the display is solid blue and shows “cooling to” rather than “cool to”.

If ISU 9000 is set for AC with low speed fan or AC with high speed fan, the T10 can run cooling up to 3 degrees below set-point when humidity is high. It will cool 1 degree below set-point for approximately every 4% RH above the dehumidify setting.



Resideo Inc., 1985 Douglas Drive North,
Golden Valley, MN 55422

www.resideo.com 33-00462-01 M.S. 08-19 | Printed in United States

This product is manufactured by Resideo Technologies, Inc., Golden Valley, MN, 1-800-633-3991
©2019 Resideo Technologies, Inc. The Honeywell Home trademark is used under license from Honeywell International Inc. All rights reserved.