



AquaSense® EV™ ZTS6200EV Series

Automatic Sensor-Operated,
Battery-Powered Flushometer

**Installation, Operation, Maintenance,
and Parts Manual**
Patented and Patents Pending



ZTS6200EV Flushometer for Water Closet
Sensor-Operated, Battery-Powered Valve

LIMITED WARRANTY

All goods sold hereunder are warranted to be free from defects in material and factory workmanship for a period of three years from the date of purchase. Decorative finishes warranted for one year. We will replace at no costs goods that prove defective provided we are notified in writing of such defect and the goods are returned to us prepaid at Sanford, NC, with evidence that they have been properly maintained and used in accordance with instructions. We shall not be responsible for any labor charges or any loss, injury or damages whatsoever, including incidental or consequential damages. The sole and exclusive remedy shall be limited to the replacement of the defective goods. Before installation and use, the purchaser shall determine the suitability of the product for his intended use and the purchaser assumes all risk and liability whatever in connection therewith. Where permitted by law, the implied warranty of merchantability is expressly excluded. If the products sold hereunder are "consumer products," the implied warranty of merchantability is limited to a period of three years and shall be limited solely to the replacement of the defective goods. All weights stated in our catalogs and lists are approximate and are not guaranteed.

PRIOR TO INSTALLATION

Prior to installing the ZTS6200EV flushometer valve, install the items listed below:

- Fixture
- Drain line
- Water supply line

IMPORTANT:

- All Plumbing is to be installed in accordance with applicable codes and regulations.
- Water supply lines must be sized to provide an adequate volume of water for each fixture.
- Flush all water lines prior to operation (See Step 2).
- Dirt and debris can cause flush valve to run continuously.
- Sensor units should not be located across from each other or in close proximity to highly reflective surfaces.

The ZTS is designed to operate with 40 to 116 psi static water pressure. Protect the chrome or special finish of this flushometer. **Do not use toothed tools to install or service the valve.**

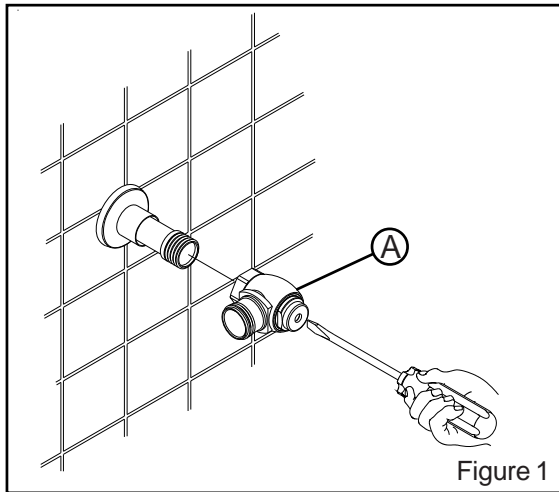

Figure 1

- 1.) Install stop valve assembly (A) using proper size supply escutcheon and sweat solder adapter kit if applicable. Thread sealing compounds should be used on male NPT threads only. **See Figure 1**

Before the supply water is turned on, be sure all stop valves are closed off tight. The stop valves can be opened and closed by using the adjusting screw (S) located at the center of the stop valve cap (T). Stop valve adjustments can only be made by using the adjusting screw (S). **It is not necessary to remove the stop valve cap (T) when making adjustments. If for any reason it becomes necessary to remove the stop valve cap (T), be certain the water is shut off at the main supply valve. See Figure 2**

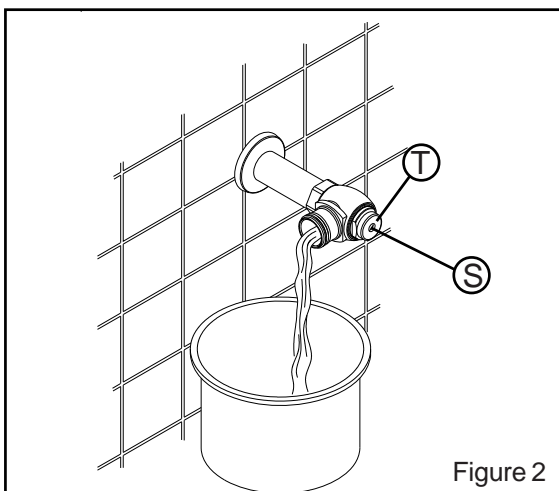

Figure 2

- 2.) When all stops are connected to the water supply and water pressure is available, it is recommended that the supply piping be flushed to remove dirt, metal chips, etc., from system.

- A. Before the valve is installed, open each stop fully for a brief time and catch the water in a two gallon or larger bucket. For multiple installations, start with the stop valve closest to the water supply and work toward the most remote valve.
- B. Due to the small passages and orifices, it is not possible to flush the piping through the low volume valve.
- C. Once the lines are flushed, the valve can be installed.

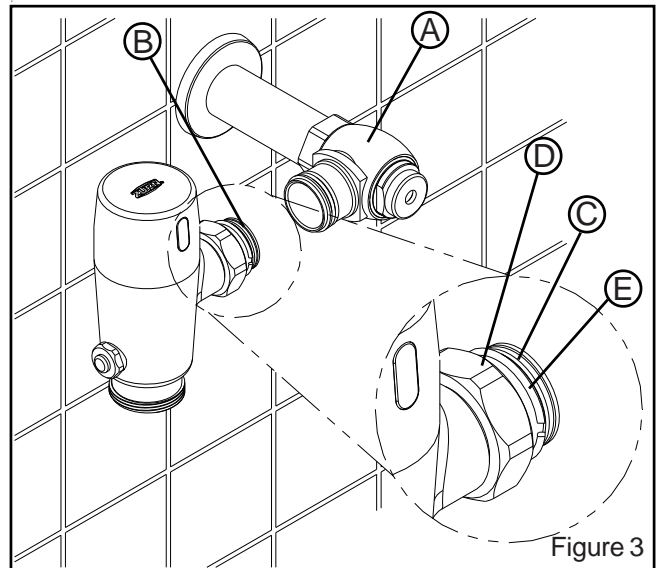
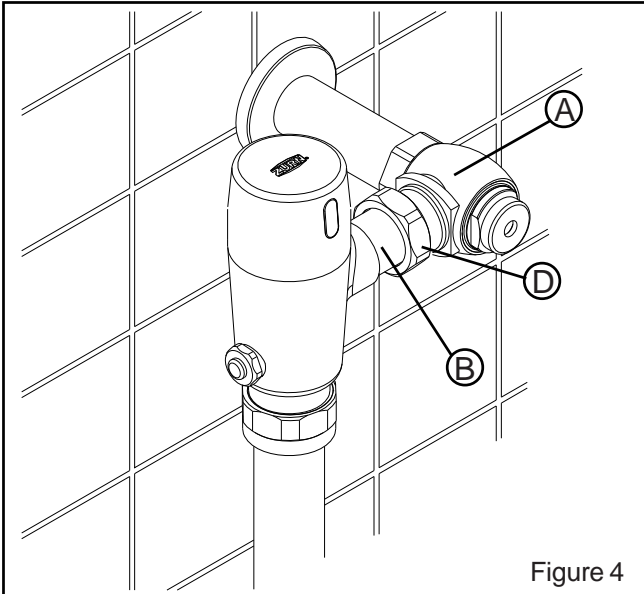
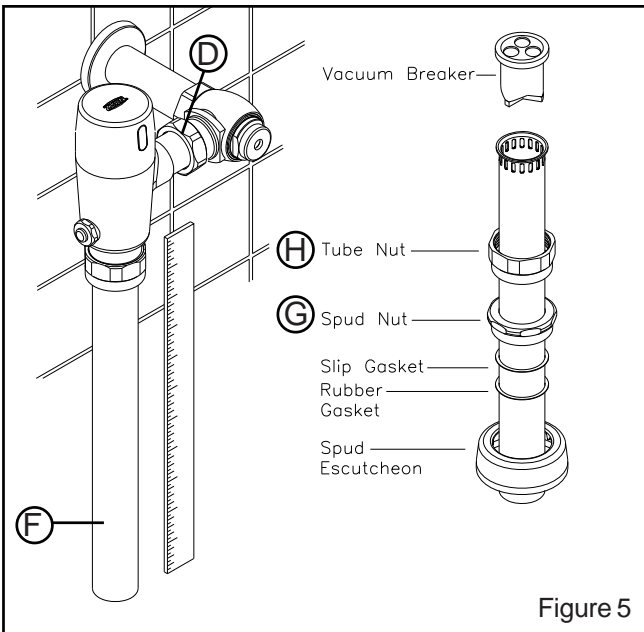

Figure 3

- 3.) Prior to inserting the flush valve tailpiece (B) into stop valve (A), be certain that the O-ring seal (C) is located in O-ring seal groove at the end of the tailpiece and that the locking nut (D) and locking snap ring (E) are located as shown. Care should be taken not to damage the O-ring when inserting the tailpiece into the stop valve. If lubrication is needed, wetting the O-ring with water will be sufficient. Tighten all connections with a non-toothed wrench. **See Figure 3**



4.) Insert the flush valve tailpiece (B) into the stop valve (A) and hand tighten the lock nut (D) to the stop valve. Plumb the entire unit. See Figure 4



5.) Determine the length of vacuum breaker tube (F) required to join the flush valve and fixture spud. Cut the vacuum breaker tube, if required, to this length. Assemble the vacuum breaker tube assembly and spud nut assembly to the flush valve and fixture spud.

6.) Hand tighten spud nut (G) and vacuum breaker tube nut (H) to fixture and flush valve. Adjust the valve assembly for plumb. Tighten fixture spud nut (G), vacuum breaker tube nut (H) and lock nut (D) with a wrench. Do not turn water on until batteries are inserted – see 7. See Figure 5

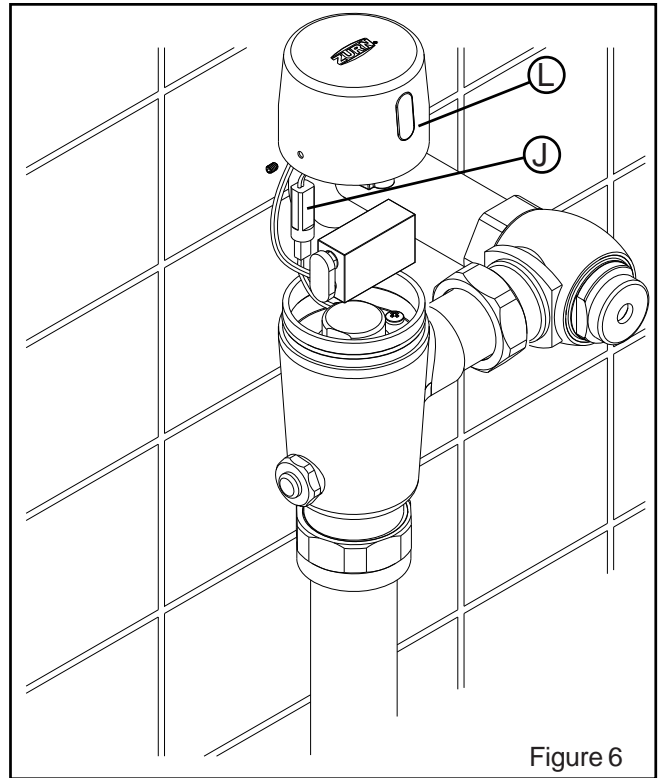

7.) ACTIVATION

Using the Allen wrench supplied with the valve, remove the set head screw holding the top cover in place. Be sure to place the screw somewhere safe so it doesn't get lost.

Remove the top cover carefully and disconnect the solenoid wire connector (J). The cover can now be taken to an appropriate work area to install the 9 volt battery provided. Place the battery into the valve housing, and reconnect the solenoid wire connector (J). Secure the top cover to the valve housing using the original screws.

Once this is completed, remove and discard the protective label (L) from in front of the lens.

Normal valve operation will occur when the valve senses an object (person). The LED will blink once. At that point the valve is charged. When object leaves view of the sensor, valve will activate. This eight second sensing cycle will prevent the valve from flushing needlessly when someone walks by. If special circumstances require adjustment of the sensing distance, see Appendix A - Changing Activation Distance.

See Figure 6

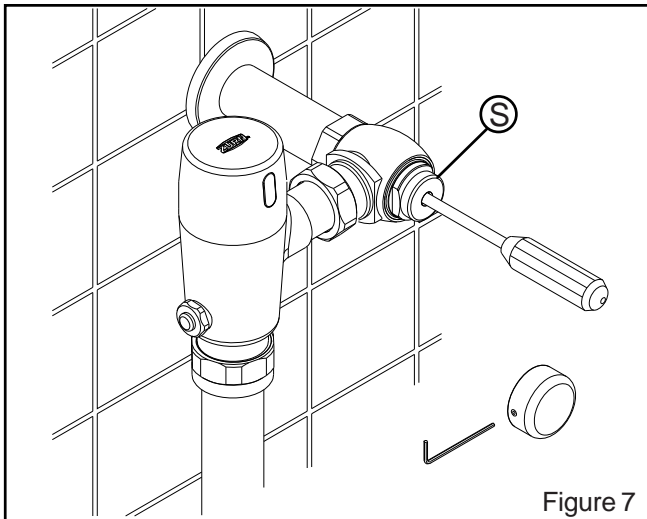

Figure 7

8.) The ZTS6200EV valve comes preset for both flow volume and sensing distance. Each valve is operated at the factory using water to insure proper function before being packed for shipment. The valve does not require water pressure regulation for variation in water pressure within the specified pressure range (40 psi to 116 psi) due to internal pressure regulation.

Open the stop valve to wide open position using the adjusting screw (S) on the front of the stop valve. The water volume will never have to be adjusted with the stop valve as on some conventional installations.

Install vandal resistant stop cover to complete the installation. See Figure 7

9.) LOW BATTERY WARNING

The LED will flash at a constant rate when the batteries reach a predetermined depletion level. The battery must be replaced within two weeks. The LED will continue the flash sequence until the batteries are replaced.

10.) BATTERY REPLACEMENT - See Figure 9

- a.) Turn off the stop valve. (A)
- b.) Remove the cover screw and remove the cap. See Figure 8
- c.) Replace the battery with a new 9V battery.
- d.) Before reassembling the electronic cap (L), make sure external o-ring is not damaged. Replace if necessary.
- e.) Make sure inside of cap is dry before re-connecting the solenoid valve connector (J).
- f.) Assemble the cap (L).
- g.) Tighten the screws.

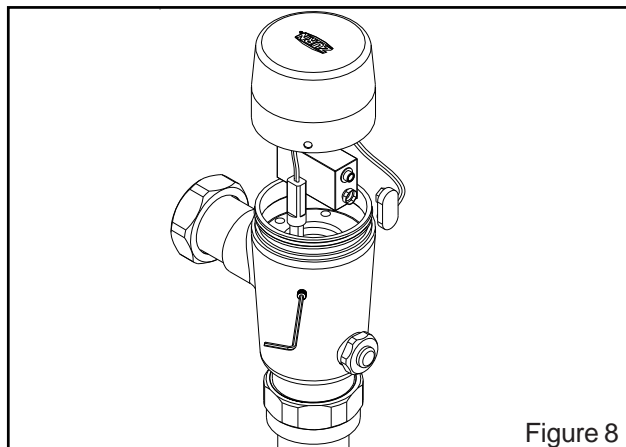

Figure 8

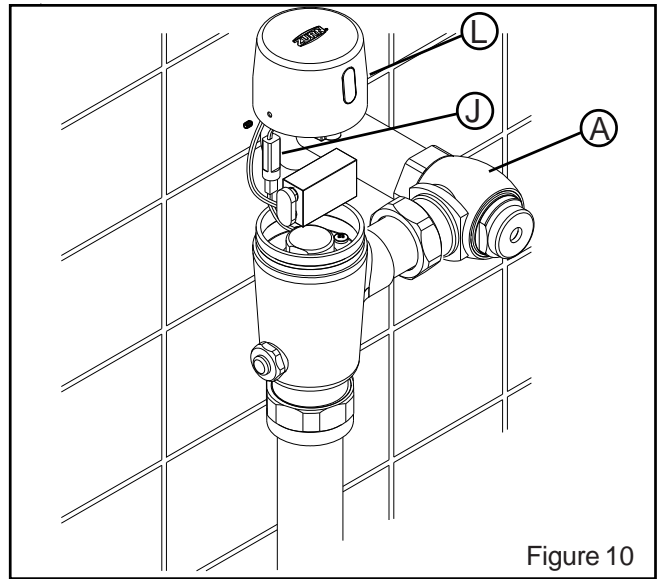
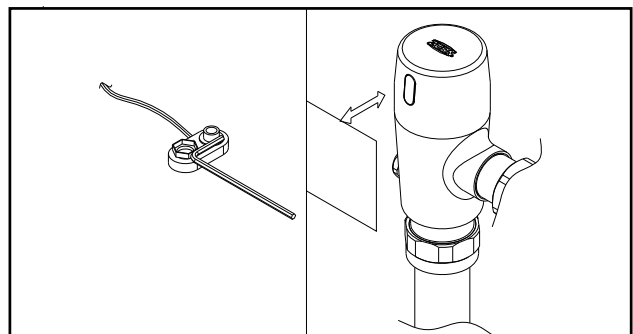

Figure 10

APPENDIX A - See Figure 10
TO CHANGE ACTIVATION DISTANCE FOR THE OBJECT LOCK SENSOR

The sensor range is the distance an object can be away from the sensor in order to activate the flush valve. The sensor is factory preset. If necessary, it can be adjusted as follows:

- 1.) Disconnect the battery from the sensor (see Battery Replacement, step 10).
- 2.) Make a short between the (+) positive and (-) negative terminals of the connector using a screwdriver or another conductor material. **Important: Do not make a short circuit on the connector when a battery is installed.**
- 3.) Reconnect the battery to the sensor.
- 4.) To enter into the adjusting mode, put your hand in front of the sensor at a distance of 2" to 4" within 5 seconds of reconnecting the battery. *Note: If you do not put your hand in front of the sensor within 5 seconds, the sensor will not enter adjustment mode and the previous adjustment will return.*
- 5.) When the sensor enters adjusting mode and your hand is in front of the sensor, a slow flashing red light will occur.
- 6.) Keep your hand in front of the sensor until the slow flashing changes into quick flashing. At this point, move your hand to the required distance from the sensor and wait until the red light will stop flashing.
- 7.) When the red light has turned off, the sensor is adjusted to the required distance.
- 8.) Check the distance you have set and if not satisfactory, repeat steps 1-6.



TROUBLE SHOOTING GUIDE

Problem	Indicator	Cause	Solution
Valve does not flush:	1.) Sensor flashes continuously when user steps within range.	1.) Low battery.	1.) Replace battery.
	2.) Red light in the sensor does not flash when user steps within the sensor's range.	1.) Range is too short 2.) Range is too long 3.) Battery is completely used up. 4.) Sensor is picking up reflections from the mirror or other objects.	1.) Increase the range. 2.) Decrease the range. 3.) Replace battery. 4.) Eliminate cause of reflection.
	3.) Red light in the sensor flashes when the user steps within the sensor's range.	1.) Connectors between the electronic unit and solenoid are disconnected. 2.) Debris or scale in solenoid. 3.) The water supply pressure is too high.	1.) Connectors of the electronics to the solenoid. 2.) Unscrew solenoid, pull out the plunger and spring from solenoid and clean them. Use scale remover material if needed. When replacing the plunger, make sure spring is in a vertical position. 3.) Reduce the water supply pressure.
Valve does not shut off:	1.) Sensor flashes when user steps within the sensor's range. 2.) Red light in the sensor does not flash when user steps within the sensor's range.	1.) Debris or scale in piston. 2.) Sensor is dirty or covered. 3.) Sensor is picking up reflections from mirror or another object.	1.) Clean the piston and the orifice. 2.) Clean or eliminate cause of interference. 3.) Decrease the range or eliminate cause of reflection.



ZTS6200EV Parts Breakdown

Parts Identification

1. Valve
2. Tailpiece O-Ring
3. Vacuum Breaker Insert
4. Duckbill
5. Vacuum Breaker Tube
6. Vacuum Breaker Tube Nut
7. Spud Nut
8. Spud Friction Washer
9. Spud Sleeve
10. Spud Escutcheon
11. Setscrew for Control Stop Cover
12. Vandal-Resistant Control Stop Cover
13. Stop Cap
14. Adjusting Screw
15. Guide Holder
16. Piston Guide
17. Guide O-Ring
18. Spring
19. Piston
20. Piston Seal
21. Stop Body
22. Sweat Solder Adapter
23. Supply Cover Tube
24. Setscrew for Cast Wall Escutcheon
25. Cast Wall Escutcheon
26. Hex Wrench
27. Cover O-ring
28. Cover screw

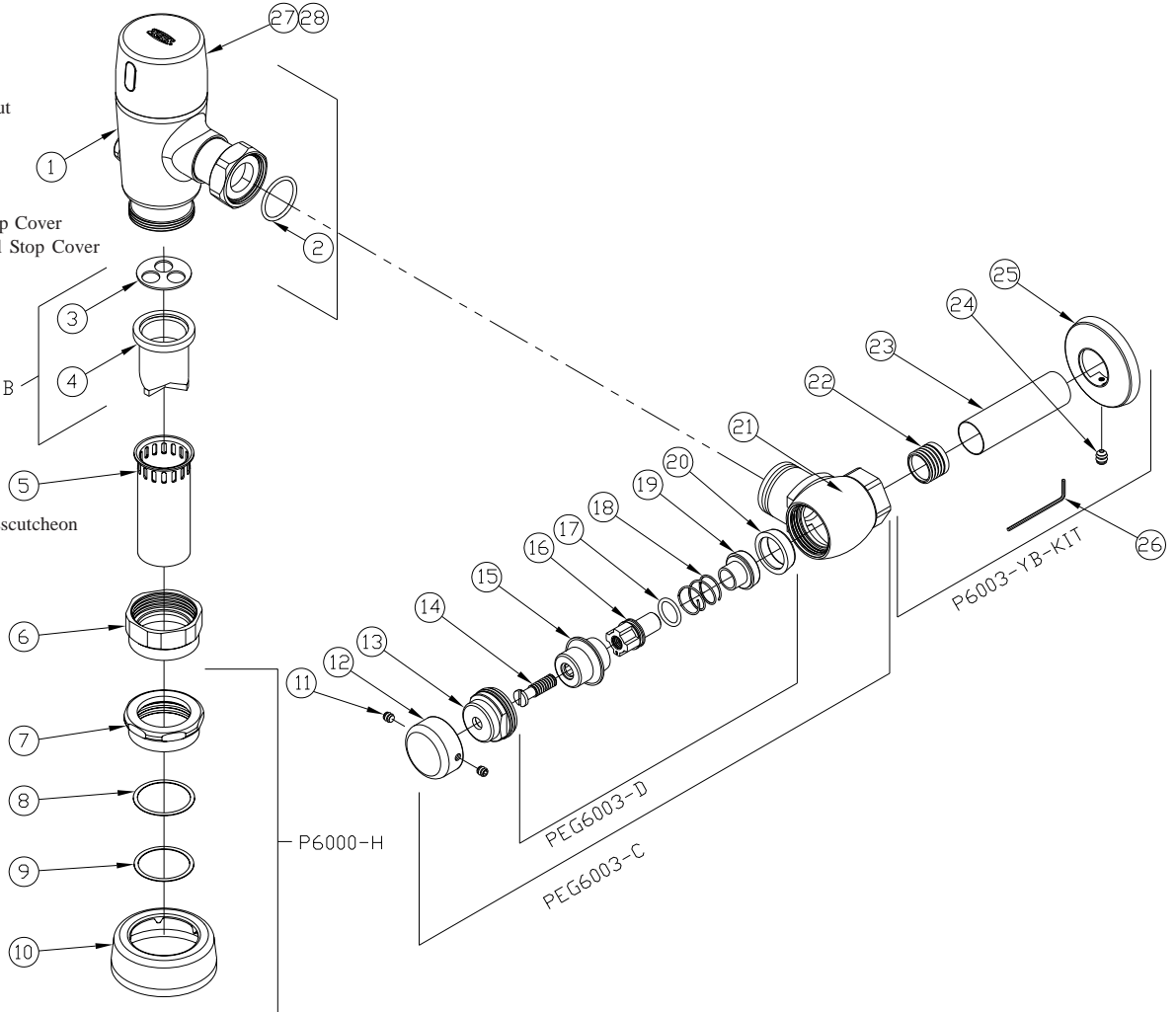

Control Stop Repair Kit and Parts	Product No.
Control Stop Repair Kit for 1" and 3/4", Includes Items 14-19	P6000-D-SD
Seal Seat for 1" and 3/4", Includes Item 19	P6000-D42
Sweat Solder Adapter, Includes Item 22	P6000-YB

Flush Connections and Spud Coupling Kits	Product No.
Flush Connection and Spud Coupling, Items 7-10	P6000-H
Vacuum Breaker Repair Kit, Items 3-4	P6000-B

Flush Connections and Spud Coupling Kits	Product No.
Cover screw, Item 27	STV6200-CVR-S

ZURN INDUSTRIES, LLC. ♦ COMMERCIAL BRASS OPERATION ♦ 5900 ELWIN BUCHANAN DRIVE ♦ SANFORD NC 27330
 Phone: 1-800-997-3876 ♦ Fax: 919-775-3541 ♦ World Wide Web: www.zurn.com
 In Canada: ZURN INDUSTRIES LLC ♦ 3544 Nashua Drive ♦ Mississauga, Ontario L4V1L2 ♦ Phone: 905-405-8272 Fax: 905-405-1292