



AquaSense®

Z6919 Series

Z6919-ADM

Sensor-Operated Lavatory Faucet for
Battery Installations.

Installation, Operation, Maintenance,
and Parts Manual

Patented and Patents Pending

Sensor-Operated Battery-Powered
Lavatory Faucet

Z6919

Z6919-ADM



Z6919-ADM

LIMITED WARRANTY

All goods sold hereunder are warranted to be free from defects in material and factory workmanship for a period of three years from the date of purchase. Decorative finishes warranted for one year. We will replace at no costs goods that prove defective provided we are notified in writing of such defect and the goods are returned to us prepaid at Sanford, NC, with evidence that they have been properly maintained and used in accordance with instructions. We shall not be responsible for any labor charges or any loss, injury or damages whatsoever, including incidental or consequential damages. The sole and exclusive remedy shall be limited to the replacement of the defective goods. Before installation and use, the purchaser shall determine the suitability of the product for his intended use and the purchaser assumes all risk and liability whatever in connection therewith. Where permitted by law, the implied warranty of merchantability is expressly excluded. If the products sold hereunder are "consumer products," the implied warranty of merchantability is limited to a period of three years and shall be limited solely to the replacement of the defective goods. All weights stated in our catalogs and lists are approximate and are not guaranteed.

IMPORTANT:

- ALL PLUMBING IS TO BE INSTALLED IN ACCORDANCE WITH APPLICABLE CODES AND REGULATIONS.
- FLUSH ALL WATER LINES PRIOR TO INSTALLATION.
- SENSOR UNITS SHOULD NOT BE LOCATED ACROSS FROM EACH OTHER OR IN CLOSE PROXIMITY TO HIGHLY REFLECTIVE SURFACES.

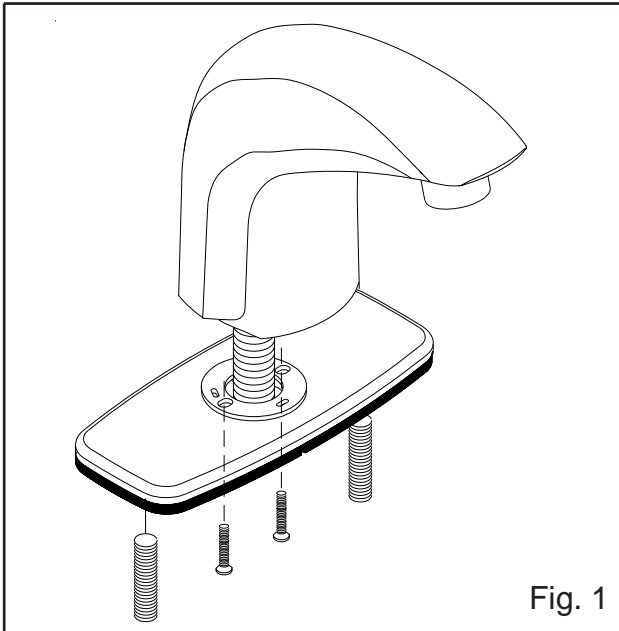

Fig. 1

1. - Cover Plate Installation

(For faucets with -CP4 or -CP8 suffix)

Place gasket on faucet shank. Align gasket with faucet bottom and pass shank through cover plate. Fasten to the faucet with the provided screws.

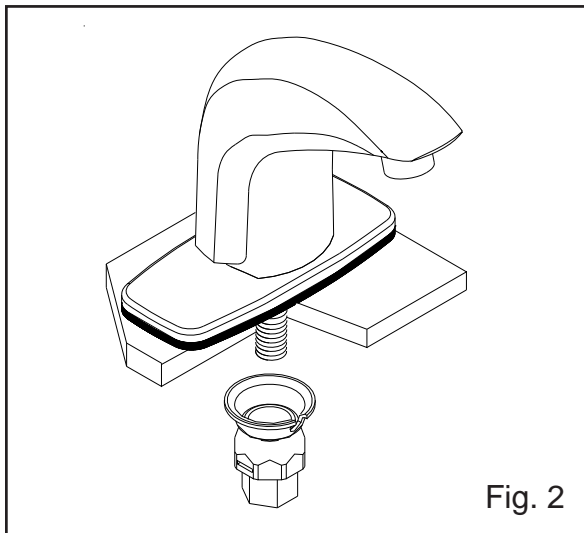

Fig. 2

2.- Spout Installation

If there is an existing faucet, turn off water supply and remove the old faucet. Assure supply lines are completely flushed and free of debris. Clean lavatory rim around the mounting area for the new sensor faucet.

Place the shank through cover plate gasket and hole in the lavatory. Place mounting washer over shank and secure the entire assembly to the lavatory with the mounting nut.

3.- Filter or Mixing Tee or Mixing Valve Installation

The supplied inlet filter must be used with every faucet, unless a mixing tee or mixing valve is ordered. The inlet filter is attached directly to the faucet shank. Tempered water is then supplied to the filter using a standard 3/8" x 1/2" ball riser (supplied by others.)

The optional mixing tee assembly (-MT) or mixing valve (-MV) have integral filters and back checks. These take the place of the standard inlet filter when ordered. The mixing tee or mixing valve outlet attaches to the faucet shank with a 3/8" x 1/2" ball riser (supplied by others). Hot and cold water is then supplied to the appropriate 3/8" compression inlets.

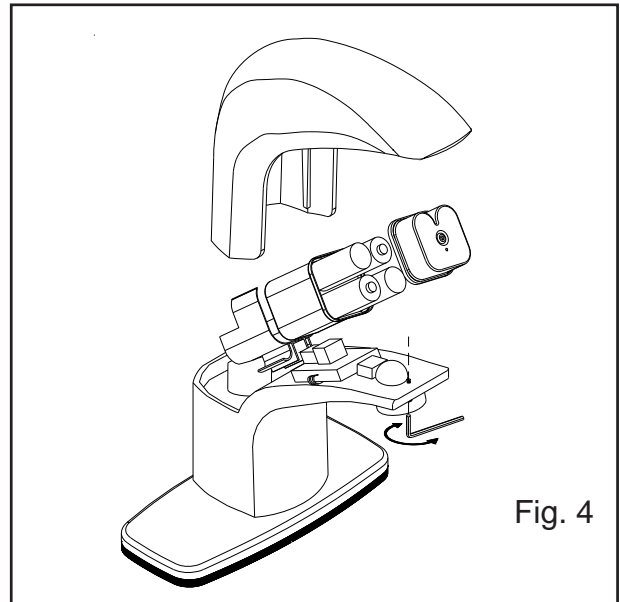

Fig. 4

4.- Battery Installation

*** DO NOT INSERT THE 4 "AA" BATTERIES BEFORE FAUCET INSTALLATION IS COMPLETE.**

*** DO NOT PLACE HAND IN FRONT OF SENSOR WINDOW WHILE INSTALLING BATTERIES OR FOR THE FIRST 30 SECONDS AFTER THE BATTERIES ARE INSTALLED.**

Remove faucet spout cover from spout by loosening the screw near the faucet aerator and sliding the cover upward. Next, locate the battery case, remove the cover and insert the provided batteries into the battery case. Place cover back on to the battery case and position the case in its nesting area. Replace spout cover and secure with screw.

5.- Faucet Setup Procedure

The sensor faucet automatically initiates an auto-calibration routine upon installation of the batteries. During this auto-calibration, the smart sensor is setting its range and adjusting for lavatory surface and room lighting. **It is important not to place anything in the sensor's range for this 30 second auto-calibration period.**

FAUCET RESET PROCEDURE

If faucet does not activate or the sensor range is too short, the Sensor Reset procedure can be used to re-calibrate the sensor. Simply place the Zurn Magic Magnet on top cover (as shown in Fig. 5) for 3 seconds, then remove. The auto-calibration routine takes place for the next 30 seconds. Be certain the sensor lens is clean and no objects are within the lavatory bowl.

Technical Assistance 1-800-997-3876

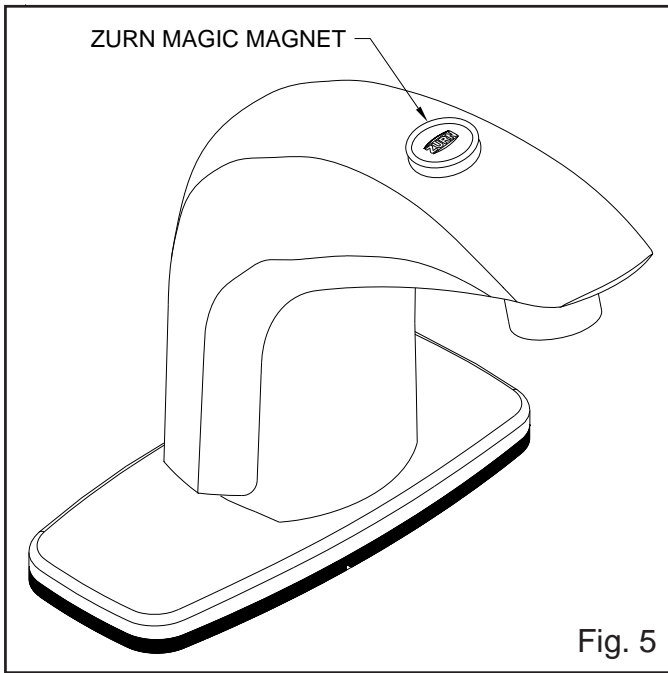

Fig. 5

5 - Cover Plate Installation-continued

Place Magic Magnet as shown for 3 seconds to reset faucet.

Z6919-ADM Installation

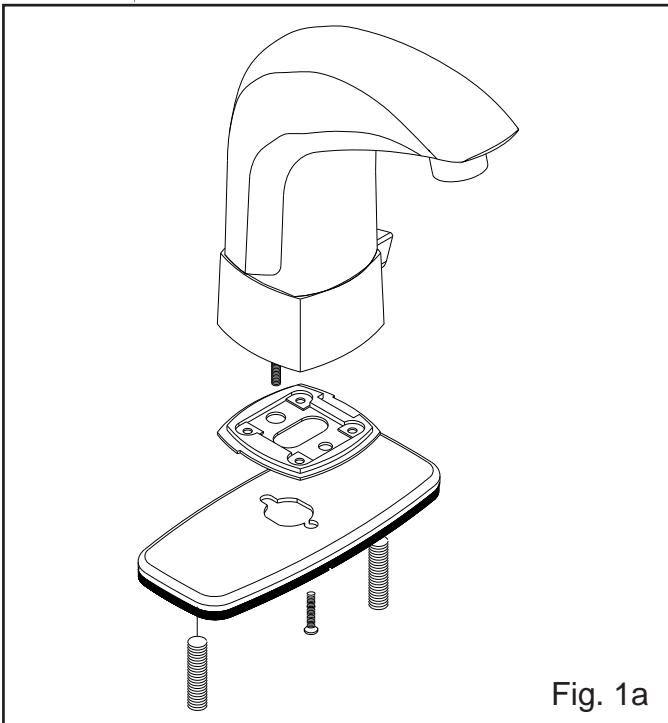

Fig. 1a

1a. - Cover Plate Installation

(For faucets with -CP4 or -CP8 suffix)
Place gasket over faucet shank. Align gasket with faucet bottom and pass shank through cover plate. Fasten to the faucet with the provided screws.

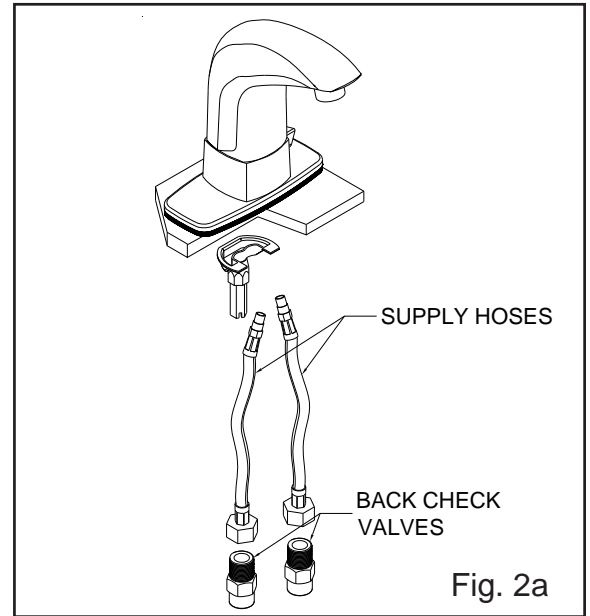

Fig. 2a

2a.- Spout Installation

If there is an existing faucet, turn off water supply and remove the old faucet. Assure supply lines are completely flushed and free of debris. Clean lavatory rim around the mounting area for the new sensor faucet.

Place the shank through cover plate gasket and hole in the lavatory. Attach supply hoses to faucet and tighten assembly to the lavatory with the mounting nut. Install back checks to stop valves, then attach supply hoses to back checks.

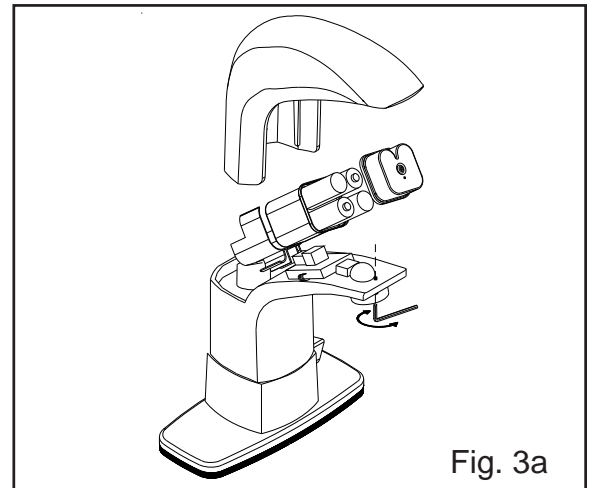

Fig. 3a

3a.- Battery Installation

*** DO NOT INSERT BATTERIES BEFORE FAUCET INSTALLATION IS COMPLETE.**

*** DO NOT PLACE HAND IN FRONT OF SENSOR WINDOW WHILE INSTALLING BATTERIES OR FOR THE FIRST 30 SECONDS AFTER THE BATTERIES ARE INSTALLED.**

Remove faucet spout cover from spout by loosening the screw near the faucet aerator and sliding the cover upward. Next, locate the battery case, remove the cover and insert the provided batteries into the battery case. Place cover back on to the battery case and position the case in its nesting area. Replace spout cover and secure with screw.



Z6919 Parts Break Down

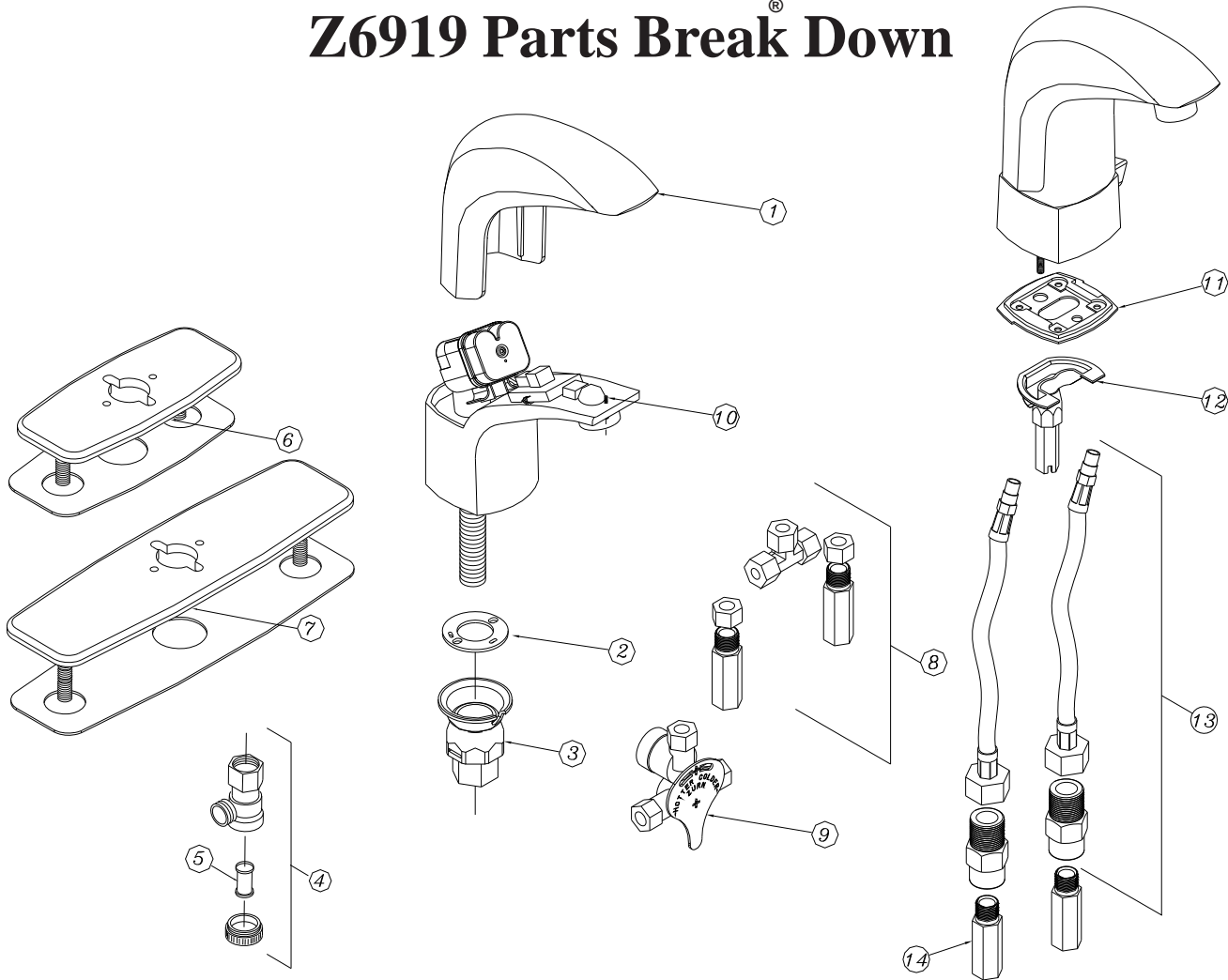

Description	Product No.
1) Cover for Body of Z6919	P6919-CVR
2) Z6919 Base Plate Gasket	P6919-42
3) Speed Nut	P6919-43
4) Filter Kit	P6900-120
5) Filter Screen	P6900-MV-7
6) 4" Cast Cover Plate w/Gasket	P6919-12CP4
7) 8" Cast Cover Plate w/Gasket	P6919-12CP8
8) Mixing Tee w/Filters and Backchecks	P6900-MT
9) Mixing Valve w/Filter	P6900-MV
10) Screw for the Body Cover	P6919-SCREW
11) Gasket for ADM	P6919-ADM-42
12) Mounting Kit for ADM	P6919-ADM-43
13) Hose for ADM	P6919-ADM-SSH
14) Backcheck Valve	P6900-MT-1

ZURN INDUSTRIES, LLC. ♦ COMMERCIAL BRASS OPERATION ♦ 5900 ELWIN BUCHANAN DRIVE ♦ SANFORD NC 27330

Phone: 1-800-997-3876 ♦ Fax: 919-775-3541 ♦ World Wide Web: www.zurn.com

In Canada: ZURN INDUSTRIES LIMITED ♦ 3544 Nashua Drive ♦ Mississauga, Ontario L4V1L2 ♦ Phone: 905-405-8272 Fax: 905-405-1292

SPECIFICATION

Voltage:	6 VDC
Sensor Range:	4"- 6" Approximate
Operating Water Pressure:	20-80 psi
Ambient Temperature:	32°F to 122°F (0°C to 50°C)
Operational Water Temperature:	35°F to 140°F (2°C to 60°C)
Aerator:	2.0 GPM Vandal-Resistant

OPERATION

- 1.) Invisible light rays are continually emitted from the faucet sensor.
- 2.) When the user's hands come into range of the sensor's detection zone (approx. 4"- 6"), the beam is reflected back to the sensor's receiver and converted to a low voltage electrical signal activating a solenoid valve.
- 3.) After the user removes their hands, the absence of reflected light stops the low voltage electrical signal, closing the valve. The circuit automatically resets for the next user.
- 4.) If an object is in view continuously for thirty seconds, the faucet will automatically shut off. The faucet will remain off until the object is removed. After the object is removed, the faucet functions normally.

CARE AND CLEANING INSTRUCTIONS

DO NOT use abrasive or chemical cleaners to clean faucets as they will dull the luster and attack the chrome or special decorative finishes. Use only mild soap and water, then wipe dry with a clean cloth or towel. While cleaning the bathroom tile and floor, the faucet and electronics should be protected from splattering of water, cleaner, acids and cleaning fluids that can damage the sensor faucet.

TROUBLESHOOTING GUIDE

PROBLEM	POSSIBLE CAUSE	TO DIAGNOSE	REMEDY
FAUCET WILL NOT FLOW WATER	Water supply not turned on.	Check supply stops.	Turn on water.
	Batteries not installed.	Check battery case.	Install batteries.
	Low batteries.	Flashing red light in sensor eye indicates low batteries.	Replace batteries.
	Solenoid valve inoperative.	Move hand in front of faucet to see if solenoid valve is clicking.	Open solenoid valve and clean it.
	Sensor/electronics are inoperative.	Move hand in front of faucet to see if solenoid valve is clicking.	Refer to steps 4 & 5 of Installation Instructions.
	Filter is plugged.	Shut off water supply. Remove clean out cap.	Clean the filter and reassemble.
FAUCET CONTINUES TO RUN FOR MORE THAN 30 SECONDS OR DRIPS	Solenoid valve is dirty.	Open the solenoid valve and check for debris. Carefully observe the way valve goes together for reassembly.	Shut off water supply. Disassemble solenoid and remove debris from diaphragm and/or plunger tip. Reassemble solenoid.



ZURN INDUSTRIES, LLC. ♦ COMMERCIAL BRASS OPERATION ♦ 5900 ELWIN BUCHANAN DRIVE ♦ SANFORD NC 27330
 Phone: 1-800-997-3876 ♦ Fax: 919-775-3541 ♦ World Wide Web: www.zurn.com
 In Canada: ZURN INDUSTRIES LIMITED ♦ 3544 Nashua Drive ♦ Mississauga, Ontario L4V1L2 ♦ Phone: 905-405-8272 Fax: 905-405-1292

AquaSense® is a registered trademark of Zurn Industries, LLC.

Printed in the U.S.A.