



# AquaSense® EV™ ZEG Series

Automatic Sensor-Operated,  
Battery-Powered Flushometer

**Installation, Operation, Maintenance,  
and Parts Manual**  
Patented and Patents Pending



**ZEG6003EV Flushometer for  
Z5798 Low Flow Urinal  
Sensor-Operated, Battery-Powered  
Urinal System**

### **LIMITED WARRANTY**

All goods sold hereunder are warranted to be free from defects in material and factory workmanship for a period of three years from the date of purchase. Decorative finishes warranted for one year. We will replace at no costs goods that prove defective provided we are notified in writing of such defect and the goods are returned to us prepaid at Sanford, NC, with evidence that they have been properly maintained and used in accordance with instructions. We shall not be responsible for any labor charges or any loss, injury or damages whatsoever, including incidental or consequential damages. The sole and exclusive remedy shall be limited to the replacement of the defective goods. Before installation and use, the purchaser shall determine the suitability of the product for his intended use and the purchaser assumes all risk and liability whatever in connection therewith. Where permitted by law, the implied warranty of merchantability is expressly excluded. If the products sold hereunder are "consumer products," the implied warranty of merchantability is limited to a period of three years and shall be limited solely to the replacement of the defective goods. All weights stated in our catalogs and lists are approximate and are not guaranteed.

## PRIOR TO INSTALLATION

Prior to installing the ZEG EcoVantage urinal flushometer valve, install the items listed below:

- Urinal fixture
- Drain line
- Water supply line

## IMPORTANT:

- All Plumbing is to be installed in accordance with applicable codes and regulations.
- Water supply lines must be sized to provide an adequate volume of water for each fixture.
- Flush all water lines prior to operation (See Step 2).
- Dirt and debris can cause flush valve to run continuously.
- Sensor units should not be located across from each other or in close proximity to highly reflective surfaces.

The ZEG is designed to operate with 20 to 80 psi (138 to 552 kPa) of water pressure. Protect the chrome or special finish of this flushometer. **Do not use toothed tools to install or service the valve.**

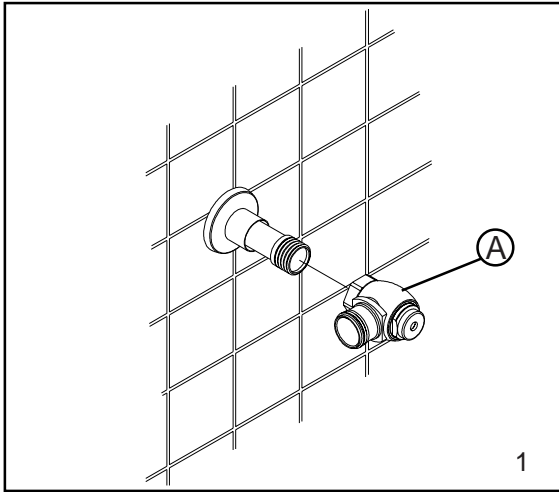

- 1.) Install stop valve assembly (A) using proper size supply escutcheon and sweat solder adapter kit if applicable. Thread sealing compounds should be used on male NPT threads only.

Before the supply water is turned on, be sure all stop valves are closed off tight. The stop valves can be opened and closed by using the adjusting screw (S) located at the center of the stop valve cap (T). Stop valve adjustments can only be made by using the adjusting screw (S). **It is not necessary to remove the stop valve cap (T) when making adjustments. If for any reason it becomes necessary to remove the stop valve cap (T), be certain the water is shut off at the main supply valve.**

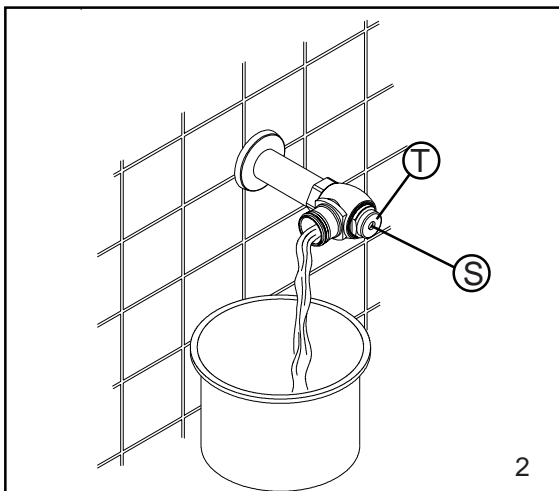

- 2.) When all stops are connected to the water supply and water pressure is available, it is recommended that the supply piping be flushed to remove dirt, metal chips, etc., from system.

- A. Before the valve is installed, open each stop fully for a brief time and catch the water in a two gallon or larger bucket. For multiple installations, start with the stop valve closest to the water supply and work toward the most remote valve.  
B. Due to the small passages and orifices, it is not possible to flush the piping through the low volume valve.  
C. Once the lines are flushed, the valve can be installed.

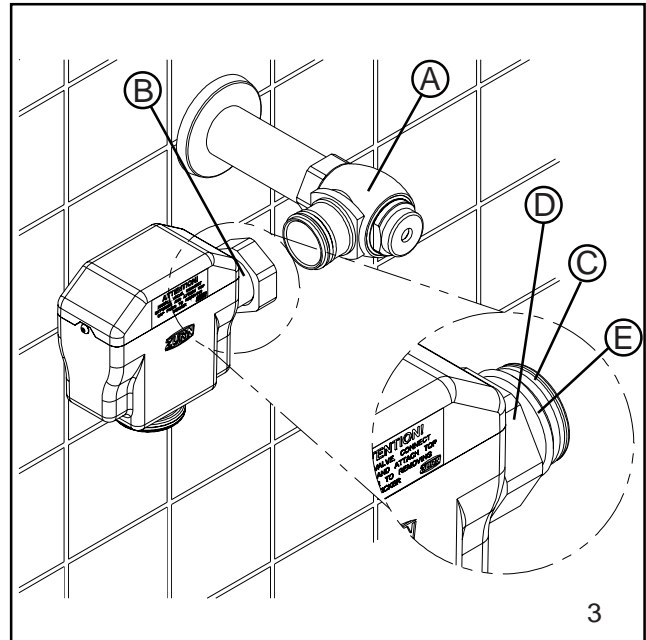

- 3.) Prior to inserting the flush valve tailpiece (B) into stop valve (A), be certain that the O-ring seal (C) is located in O-ring seal groove at the end of the tailpiece and that the locking nut (D) and locking snap ring (E) are located as shown. Care should be taken not to damage the O-ring when inserting the tailpiece into the stop valve. If lubrication is needed, wetting the O-ring with water will be sufficient.

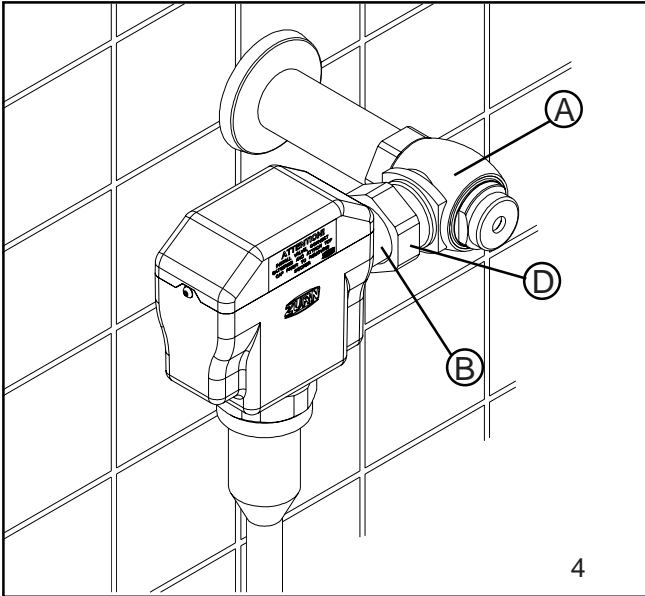

4.) Insert the flush valve tailpiece (B) into the stop valve (A) and hand tighten the lock nut (D) to the stop valve. Plumb the entire unit.

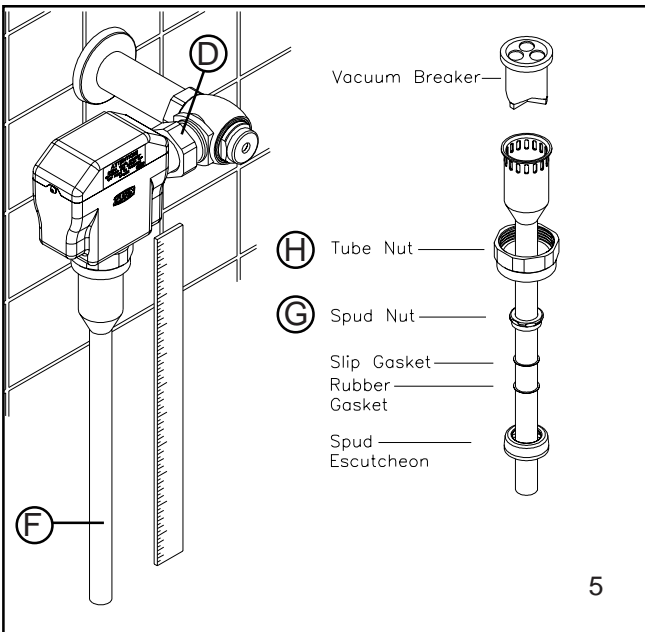

5.) Determine the length of vacuum breaker tube (F) required to join the flush valve and fixture spud. Cut the vacuum breaker tube, if required, to this length. Assemble the vacuum breaker tube assembly and spud nut assembly to the flush valve and fixture spud.

6.) Hand tighten spud nut (G) and vacuum breaker tube nut (H) to fixture and flush valve. Adjust the valve assembly for plumb. Tighten fixture spud nut (G), vacuum breaker tube nut (H) and lock nut (D) with a wrench. **Do not turn water on until batteries are inserted – see 7.**

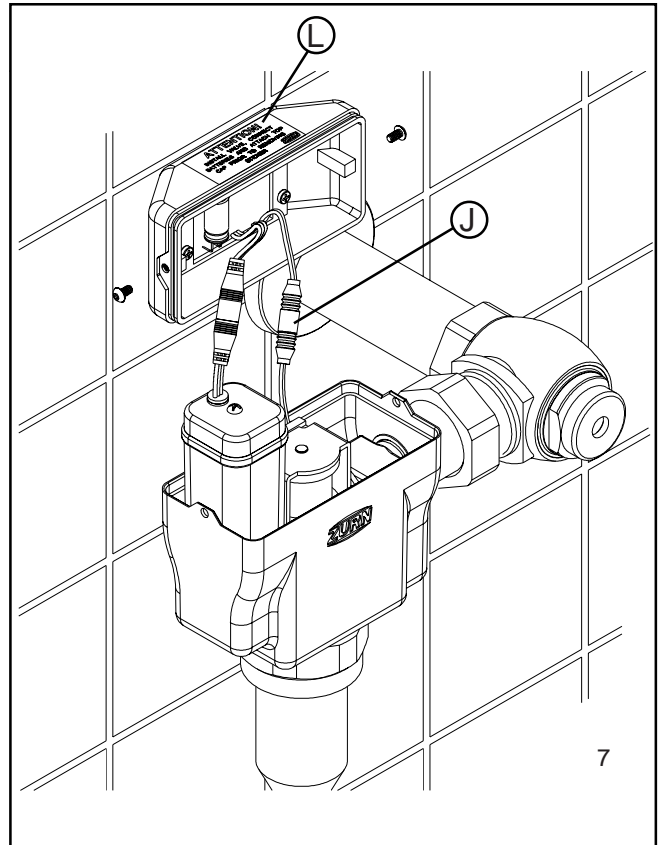

#### 7.)ACTIVATION

Using the 5/64" Allen wrench supplied with the valve, remove the two 6-32 button head screws holding the top cover in place. Be sure to place the screws somewhere safe so they don't get lost.

Remove the top cover carefully and disconnect the solenoid wire connector (J). The cover and battery case can now be taken to an appropriate work area to install the AA cell batteries provided.

Load the four heavy duty AA alkaline batteries following the battery orientation guide on the battery box. Note that the coil springs always contact the flat (negative) end of the battery. Secure the battery case lid and gasket with screw provided. Place the battery box into the valve housing, and reconnect the solenoid wire connector (J). Secure the top cover to the valve housing using the original screws.

Once this is completed, remove and discard the protective label (L) from in front of the lens.

Normal valve operation will occur when the valve senses an object (person). The LED will blink brightly once and then dimly three times about a second apart. There will be a pause and then a double blink. At that point the valve is charged. When object leaves view of the sensor, valve will activate. This six second sensing cycle will prevent the valve from flushing needlessly when someone walks by. If special circumstances require adjustment of the sensing distance, see Appendix A - Changing Activation Distance.

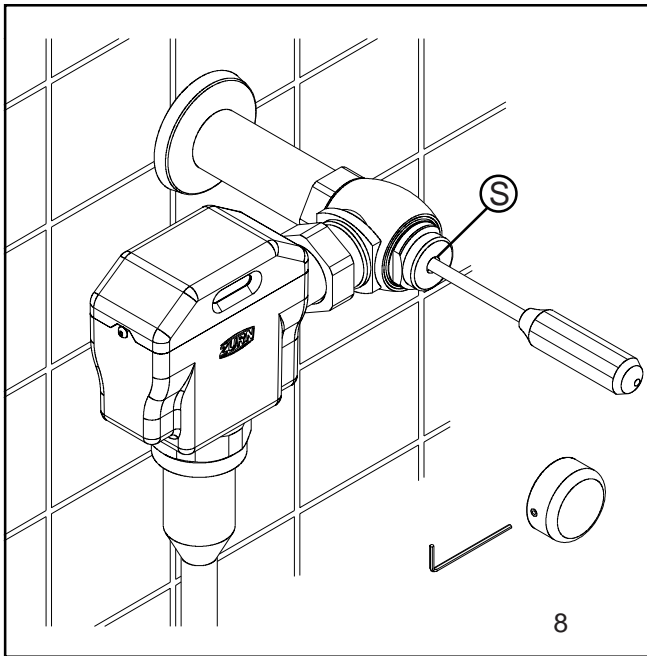

8.) The ZEG urinal valve comes preset for both flow volume and sensing distance. Each valve is operated at the factory using water to insure proper function before being packed for shipment. The valve does not require water pressure regulation for variation in water pressure within the specified pressure range (20 psi to 80 psi) due to internal pressure regulation.

Open the stop valve to wide open position using the adjusting screw (S) on the front of the stop valve. The water volume will never have to be adjusted with the stop valve as on some conventional urinal installations. Install vandal resistant stop cover to complete the installation.

9.) LOW BATTERY WARNING

The LED will double flash every fifteen seconds when the batteries reach a predetermined depletion level. There are approximately five hundred more flushes available once the LED starts flashing, at which time the valve will stop operating. The LED will continue the flash sequence until the batteries are replaced.

10.) FILTER

**When accessing filter, be certain the stop valve is closed at adjusting screw (S) Figure 8.**

The filter is accessible from the bottom of the valve using a slot head screw driver. The filter will come out with the plug and can be cleaned with water and a soft brush.

When replacing be sure o-ring (M) is in place and undamaged.

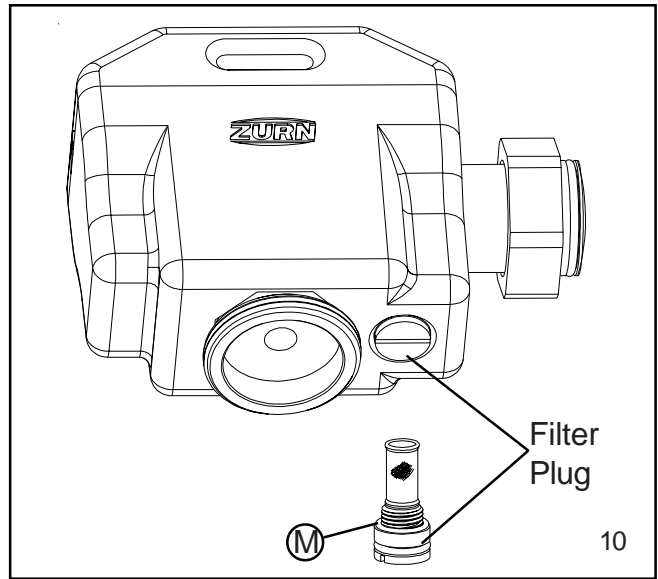

**APPENDIX A  
TO CHANGE ACTIVATION DISTANCE FOR  
THE OBJECT LOCK SENSOR**

The valve does not have to be disabled in any way to change the detection range. Included with each valve is a Zurn "Magic Magnet" that is used to initiate the auto-calibration mode. Calibration is accomplished as follows.

1. Place the Zurn "Magic Magnet" (N) on the left hand side of the flat top surface of the valve and move around until the LED comes on.
2. The LED will blink once brightly, then nine times dimly, then a final bright flash. A solid red light will appear in the sensor eye. This means the electronics are ready to calibrate.
3. Remove the magnet and stand in front of sensor about 20" away for the rest of the calibration. The calibration process takes about 60 seconds. Do not move during this process.
4. When calibration is completed the solid red light will disappear and the LED will blink twice brightly.

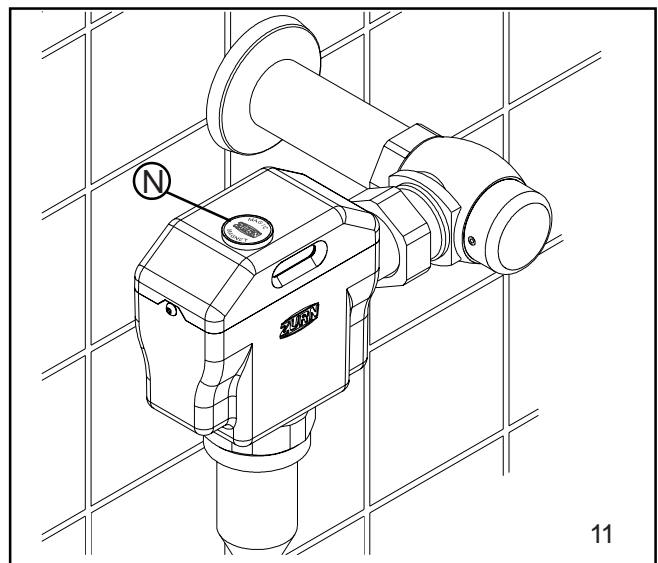

## TROUBLE SHOOTING GUIDE

Problem	Possible Cause	Diagnosis	Solution
No lights are visible in the sensor eye. Valve does not flush.	Electronics fault.	Run through reset procedure below.	
	Valve could be sensing a close by surface or reflections from some opposite surface.	Hold a flat object at an acute angle to the valve and see if it flushes ( three ring binder works well)	Reduce sensing range Eliminate reflective object.
	Lens could be dirty or damaged.	Visual inspection of batteries and battery case.	Replace if obstructed or damaged
	Battery leads disconnected or broken wire.	Check plug insertion and wire continuity.	Reinsert plug or repair leads
	Battery corrosion has caused loss of contact.	Visual inspection	Replace batteries and clean or replace battery box
	Sensor not detecting user.	Hold hand at different ranges in front of valve to see if it can be detected.	Reset sensor range (Appendix A)
Light flashes randomly in sensor eye and valve does not flush	Electronics fault	Run through reset procedure below	
Lights follow normal sequence, valve does not flush.	Water not turned on.	Close stop, disconnect valve, crack stop to check for water.	Find source valve and turn on.
	Plugged filter.	Close stop, remove and inspect filter.	Clean and reinstall filter
	Stop valve closed.	Check stop screw.	Open stop valve
	Wiring fault.	Check solenoid leads and and insertion of solenoid plug.	Reinsert plug or repair wiring
	Solenoid malfunction.		Clean P6900-SRK components. See parts list
Valve flushes but does not shut off.	Diaphragm damage or plugged diaphragm orifice.	Visual inspection.	Replace diaphragm
	Solenoid malfunction		Clean P6900-SRK components. See parts list
Leaks	Incorrectly installed.	Check for leak location.	Remove and reinstall. Pay close attention to alignment of inlet tube and outlet boss with mating pieces.
	Damaged O-ring on inlet tube.	Check for cuts.	Replace O-ring
LED flashes every 15 seconds.	Low battery voltage		Replace batteries

**Electronics Reset Procedure:** Disconnect solenoid wires ((J) Figure 7). Remove batteries from battery case. Allow electronics to set without batteries installed for a minimum of 4 minutes. Place batteries in battery case (watch for proper polarity). Secure battery case lid and gasket with screw provided. Reconnect solenoid wire connector. Place battery case back in valve housing. Place valve cover back on valve housing, carefully tuck wires into housing. Secure cover with two screws provided.



# ZEG6003EV 1/8th Gallon Urinal Parts Breakdown

## Parts Identification

1. Cover
2. Cover Screw
3. Electronics Assembly
4. Lens Assembly
5. Battery Tray
6. Housing
7. Solenoid
8. Screw
9. Spring
10. Plunger
11. Diaphragm
12. Valve Body
13. Filter
14. O-Ring
15. Filter Cap
16. O-Ring
17. Tailpiece O-Ring
18. Vacuum Breaker Insert
19. Duckbill
20. Vacuum Breaker Tube
21. Vacuum Breaker Tube Nut
22. 3/4" Spud Nut
23. 3/4" Spud Friction Washer P6000-B
24. 3/4" Spud Sleeve
25. 3/4" Spud Escutcheon
26. Magic Magnet
27. Setscrew for Control Stop Cover
28. Vandal-Resistant Control Stop Cover
29. Stop Cap
30. Adjusting Screw
31. Guide Holder
32. Piston Guide
33. Guide O-Ring
34. Piston
35. Piston Seal
36. Stop Body
37. Sweat Solder Adapter
38. Supply Cover Tube
39. Setscrew for Cast Wall Escutcheon
40. Cast Wall Escutcheon
41. Hex Wrench
42. Cover O-ring

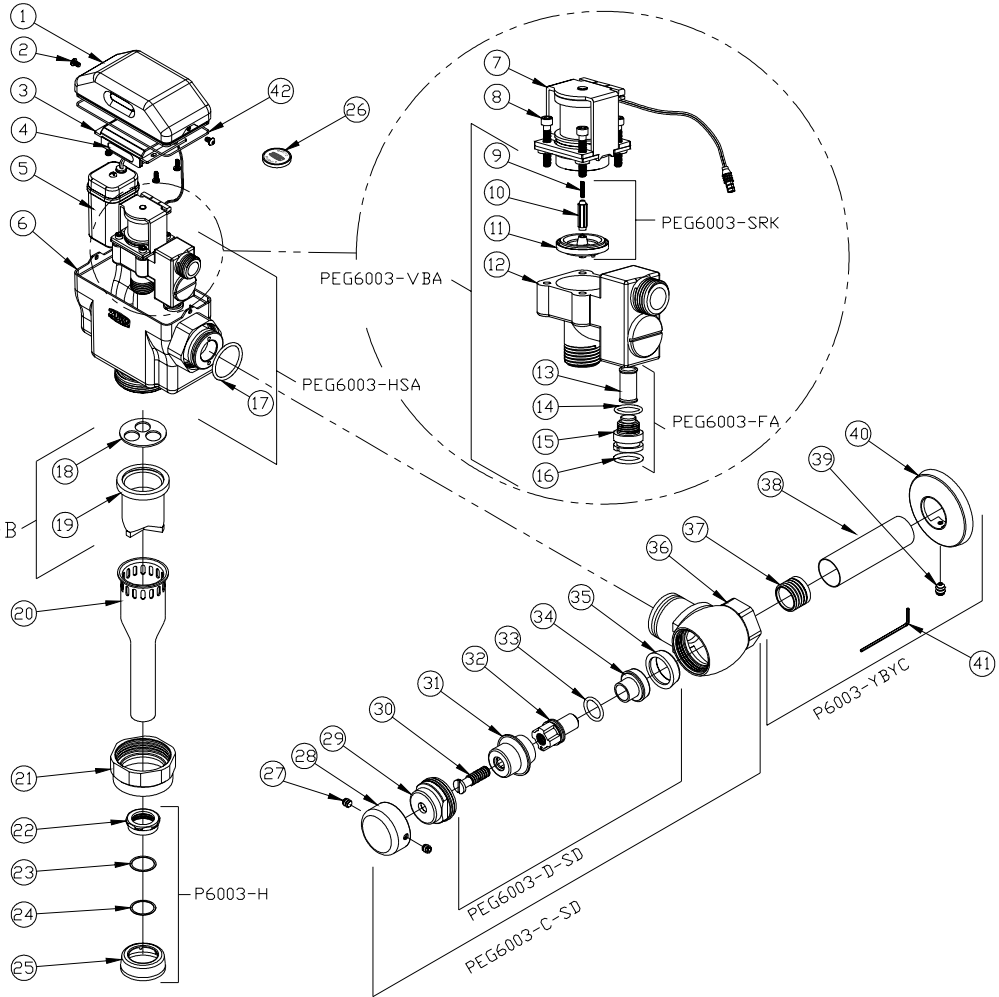

Control Stop Repair Kit and Parts	Product No.
Control Stop Repair Kit for 1" and 3/4", Includes Items 30-35	PEG6000-D-SD
3/4" Control Stop Replacement, Includes Items 29-36	PEG6003-C-SD-CP
Seal Seat for 1" and 3/4", Includes Item 35	P6000-D42
Sweat Solder Adapter, Includes Item 37	P6003-YBA
Sweat Kit and Escutcheon, Includes Items 37-41	P6003-YBYC

Flush Connections and Spud Coupling Kits	Product No.
3/4" Flush Connection and Spud Coupling, Items 22-25	P6003-H
Vacuum Breaker Repair Kit, Items 18-19	P6000-B

Lid and Housing Kits	Product No.
1/8 GPF Cover Replacement Kit P, Item 1	PEG6003-L-1
1/8 GPF Cover Replacement Kit S, Item 1	PEG6003-L-2
1/8 GPF Housing Replacement Kit P, Items 6-17	PEG6003-HSA-1
1/8 GPF Housing Replacement Kit S, Items 6-17	PEG6003-HSA-2
1/8 GPF Lid O-ring, Item 42	PEG6003-CVR-ORING

Solenoid and Valve Kits	Product No.
1/8 GPF Valve Bobby Replacement Kit, Items 9-16	PEG6003-VBA
1/8 GPF Solenoid Repair Kit, Items 9-11	PEG6003-SRK
1/8 GPF Solenoid Replacement Kit, Items 7-8	PEG6003-M
1/8 GPF Filter Replacement Kit, Items 13-16	PEG6003-FA

Replacement Parts and Repair Kits	Product No.
1/8 GPF Cover screw, Item 2	PEG6003-CVR-S
1/8 GPF Electronics Assembly, Item 3	PEG6003-EL
1/8 GPF Lens Assembly, Item 4	PEG6003-SC
1/8 GPF Battery Tray, Item 5	PEG6003-BD

ZURN INDUSTRIES, LLC. ♦ COMMERCIAL BRASS OPERATION ♦ 5900 ELWIN BUCHANAN DRIVE ♦ SANFORD NC 27330

Phone: 1-800-997-3876 ♦ Fax: 919-775-3541 ♦ World Wide Web: www.zurn.com

In Canada: ZURN INDUSTRIES LIMITED ♦ 3544 Nashua Drive ♦ Mississauga, Ontario L4V1L2 ♦ Phone: 905-405-8272 Fax: 905-405-1292