



# KITCHEN SINK FAUCET Z871B2-XL

TAG \_\_\_\_\_



### Engineering Specifications: Zurn AquaSpec® Z871B2-XL

Polished chrome-plated 8" [203mm] brass deck faucet with a 5-3/8" [137mm] centerline rigid or swing gooseneck spout and quarter turn ceramic disc cartridges. Unit is furnished with a 2.2 GPM [8.3 L] pressure compensating aerator (complying with ANSI A112.18.1 Standard for flow), vandal-resistant color-coded metal four arm handles, mounting hardware and 1/2" NPSM coupling nuts for standard lavatory risers.

Zurn Lead Free products (-XL), is the line of durable, high quality brass faucets and fixtures that are designed and manufactured to comply with state laws and local codes that mandate lead content levels. Zurn Lead Free products (-XL) are manufactured with less than one quarter of one percent (0.25%) total lead content by weighted average.

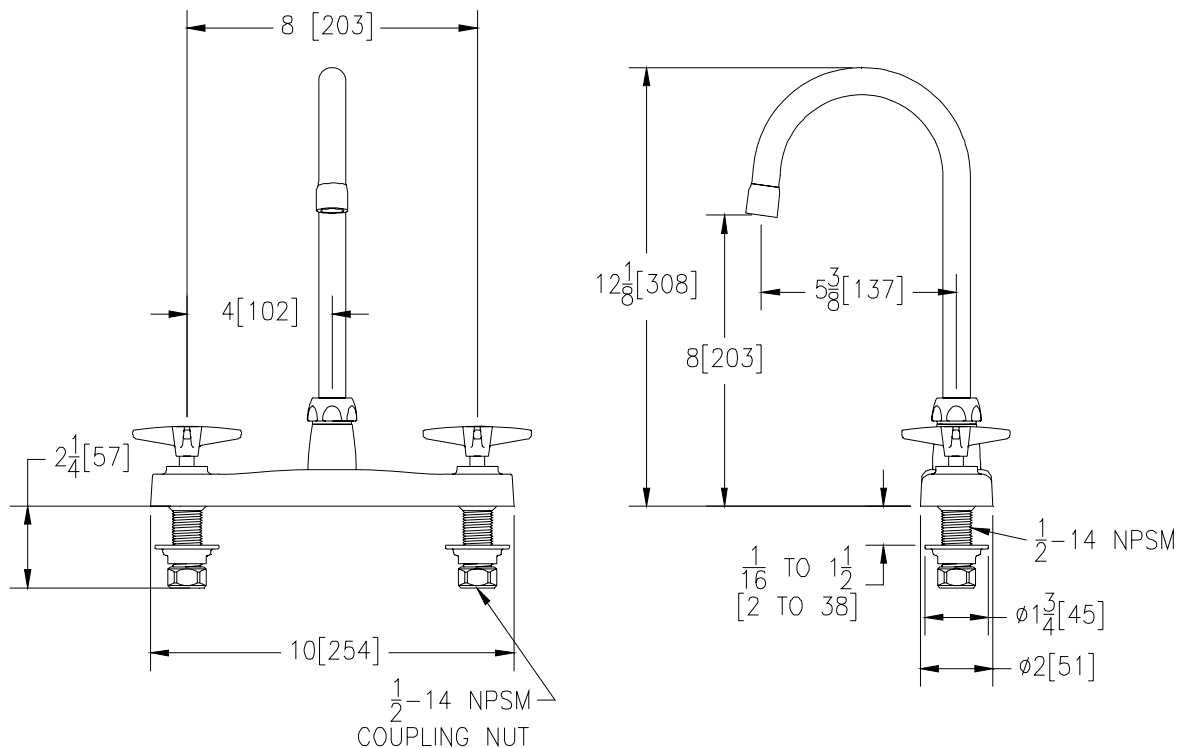

Note: All dimensions are for reference only. Do not use for pre-plumbing

### OPTIONAL ACCESSORIES

Suffix	Description
___-FC	2.0 GPM [7.6 L] Laminar Flow Control in Base of Spout
___-HCT	Hot/Cold Text Indexes
___-HS	Hose and Spray
___-PT	1-1/4" [32mm] Cast Brass P-Trap with a 7-1/2" [191mm] Long 17-Gauge Wall Bend
___-2F	2.2 GPM [8.3 L] Vandal-Resistant Pressure Compensating Female Aerator
___-3F	0.5 GPM [1.9 L] Vandal-Resistant Pressure Compensating Female Spray Outlet
___-4F	2.2 GPM [8.3 L] Vandal-Resistant Pressure Compensating Female Laminar Flow Outlet
___-7F	1.0 GPM [3.8 L] Pressure Compensating Female Spray Outlet
___-16F	1.0 GPM [3.8 L] Vandal-Resistant Pressure Compensating Female Spray Outlet
___-17F	1.5 GPM [5.7 L] Vandal-Resistant Pressure Compensating Female Aerator
___-18F	1.5 GPM [5.7 L] Vandal-Resistant Pressure Compensating Female Laminar Flow

ZURN INDUSTRIES, LLC ♦ COMMERCIAL BRASS OPERATION ♦ 2640 SOUTH WORK STREET ♦ FALCONER NY 14733

Phone: 1-716-665-1132 ♦ Fax: 1-716-665-1135 ♦ World Wide Web: [www.zurn.com](http://www.zurn.com)

In Canada: ZURN INDUSTRIES LIMITED ♦ 3544 Nashua Drive ♦ Mississauga, Ontario L4V1L2 ♦ Phone: 905/405-8272 Fax: 905/405-1292