



PRE-RINSE Z825X1-XL TAG _____

Engineering Specification: Zurn AquaSpec® Z825X1-XL

Polished chrome plated deck mounted pre-rinse faucet with an integral shank, a quarter turn ceramic disc cartridge and a 2-1/2 [64mm] vandal resistant color-coded metal lever handle. Unit is furnished with a 24" [610mm] riser with a 36" [914mm] stainless steel spring hose, a self-closing 1.6 GPM @ 60 psi (6.1 L/min. @ 400 kPa) pre-rinse hand held valve with an insulated 6" [152mm] handle, a stay open clip, a protective bumper spray head, a pipe support and a hook.

Zurn Lead Compliant* "XL" products are a line of durable, high quality brass faucets and fixtures that are designed and manufactured to comply with state laws and local codes that mandate lead content levels. Zurn "XL" products are manufactured with *not more than 0.25% lead content when used with respect to wetted surfaces of pipes and pipe fittings, plumbing fitting and fixtures: California Health & Safety Code § 116875; Vermont 9 VCA § 2470h.

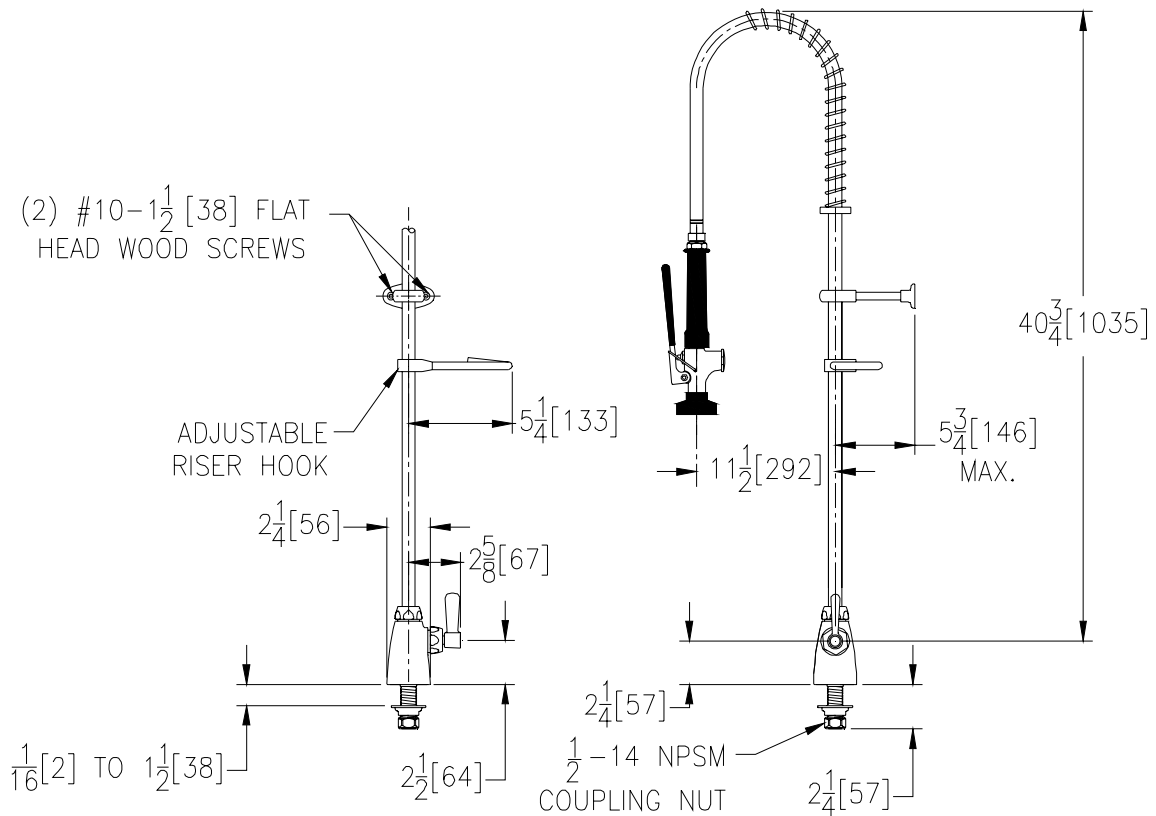

Note: All dimensions are for reference only. Do not use for pre-plumbing

OPTIONAL ACCESSORIES

Suffix	Description
___ -AR	Anti-Rotation Pins
___ -HCT	Hot/Cold Text Indexes
___ -PR2	Pre-rinse with Angle Spray Head, Rubber Bumper Spray Outlet and Self-closing Valve

ZURN INDUSTRIES, LLC ♦ COMMERCIAL BRASS OPERATION ♦ 2640 SOUTH WORK STREET ♦ FALCONER NY 14733

Phone: 1-800-997-3876 ♦ Fax: 1-919-775-3541 ♦ www.zurn.com

In Canada: ZURN INDUSTRIES LIMITED ♦ 3544 Nashua Drive ♦ Mississauga, Ontario L4V1L2 ♦ Phone: 905/405-8272 Fax: 905/405-1292