

Dimensional Data (inches and [mm]) are Subject to Manufacturing Tolerances and Change Without Notice

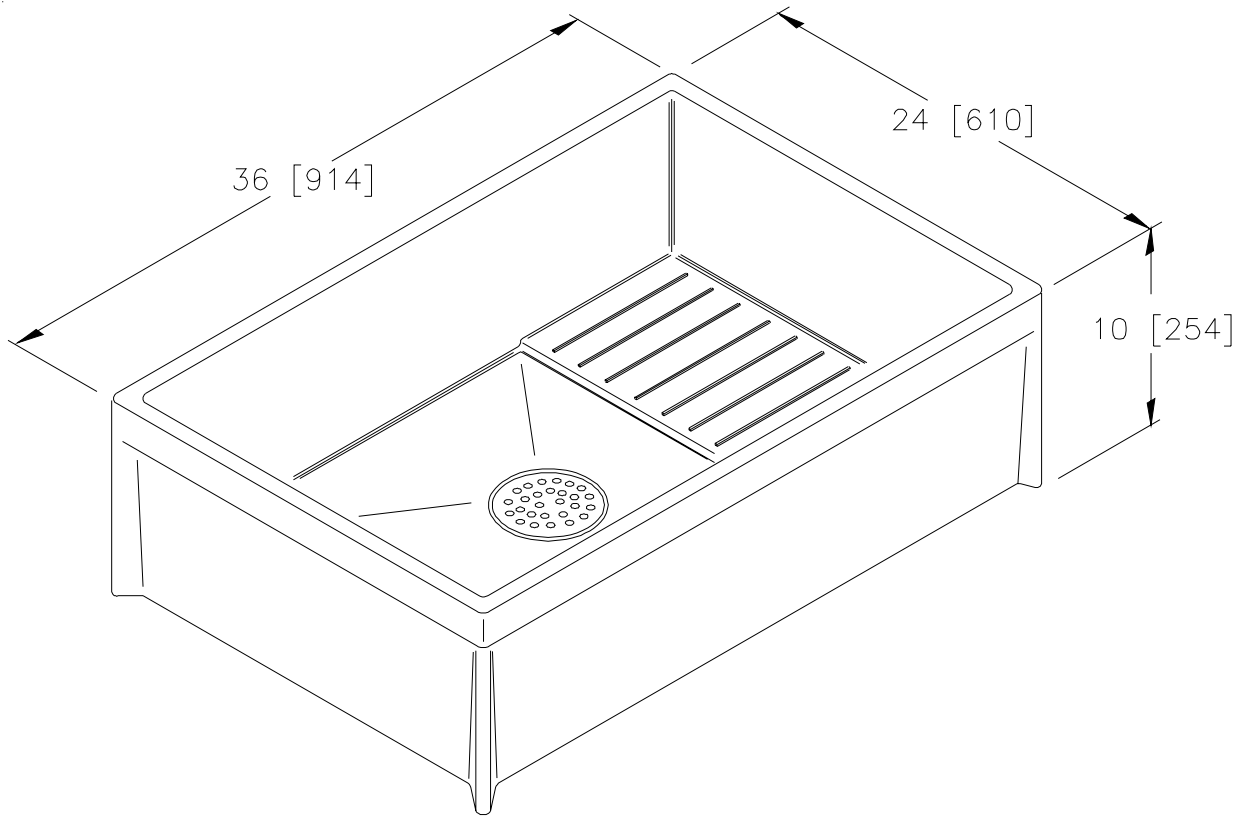

Product	Mop Basin Size	Approx. Wt. Lbs. [kg]
___ Z1996-36	36 x 24 x 10 [914 x 610 x 254]	55 [25]

ENGINEERING SPECIFICATION: Z1996-36

24 x 36 x 10 [914 x 610 x 254] Mop Service Basin. Molded high density composite basin with an integrally molded, self-draining mop shelf, PVC drain body, stainless steel dome strainer/ lint basket, and 3 [76] gasketed outlet connection. Certifications: Meets ANSI Z124.6, CSA listed, and IAPMO listed under file # 3561.

OPTIONS

- ___ -BS Stainless Steel Bumper Guard
- ___ -BV Vinyl Bumper Guard
- ___ -HH Hose and Hose Bracket
- ___ -MH Mop Hanger
- ___ -NHG PVC Drain Gasket for No-Hub Pipe
- ___ -PRP Pipe Reducer for PVC Drain
- ___ -PRS Pipe Reducer for Stainless Steel drain
- ___ -SD 3 [76] Stainless Steel Drain
- ___ -SDL Stainless Steel Drain with Locking Nut
- ___ -SF Service Faucet
- ___ -WG Wall Guard #20 Gage Type 304 Stainless Steel (2 Panels-Indicate Size)

