

Dimensional Data (inches and [mm]) are Subject to Manufacturing Tolerances and Change Without Notice

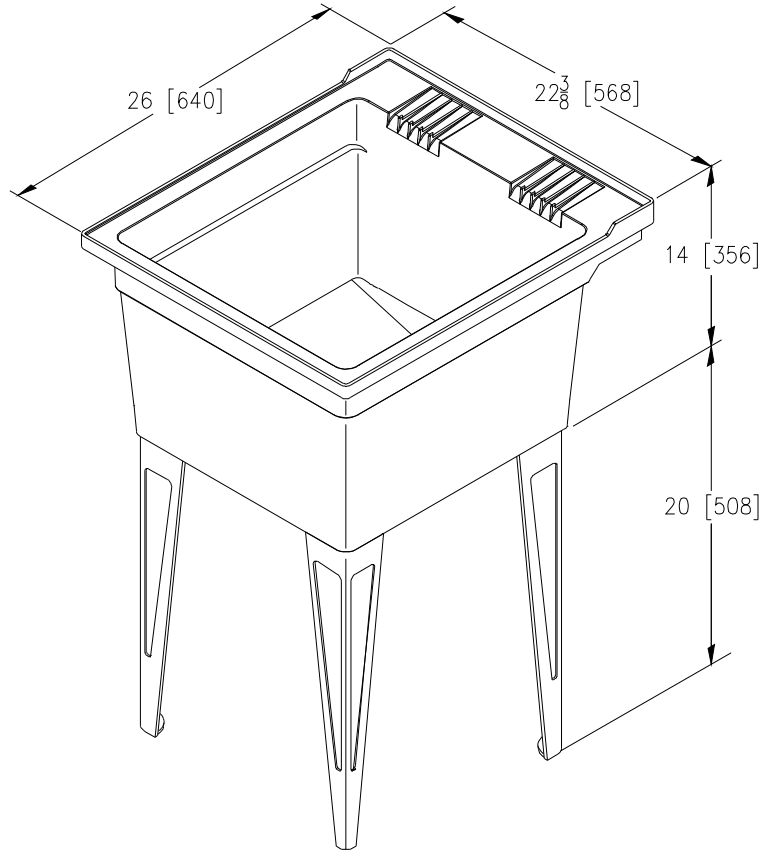

Model Number	Description
MS2620-F	Floor Mounted Multi-Purpose Sink
MS2620-W	Wall Mounted Multi-Purpose Sink*

MS2620 Single compartment, multi-purpose sink manufactured from an innovative foam process. The polypropylene structural composite sink utilizes this unique molding process, producing seamless corners and edges while providing unrivaled strength. Floor mounted units are equipped with coated steel, self-leveling legs.

OPTIONS (Check/specify appropriate options)

SUFFIXES

- ___ -AP Accessory Package
- ___ -DF1 Dual Handle Deck Faucet
- ___ -DF2 Single Lever Deck Faucet
- ___ -FA Top Supplied Deck Faucet
- ___ -FP Filler Panel
- ___ -PL Polyethylene Legs
- ___ -TS Top Supplied Faucet

OPTIONAL COLORS (Gray-Standard)

- ___ -AW Appliance White



*Wall-mounting brackets with hardware and filler panels included.