

## INDUSTRIAL SOAP/LOTION DISPENSER

# 9065

- Max Counter Thickness 2-3/8"
- Install Hole Size Adaptable Up to 1-3/8"

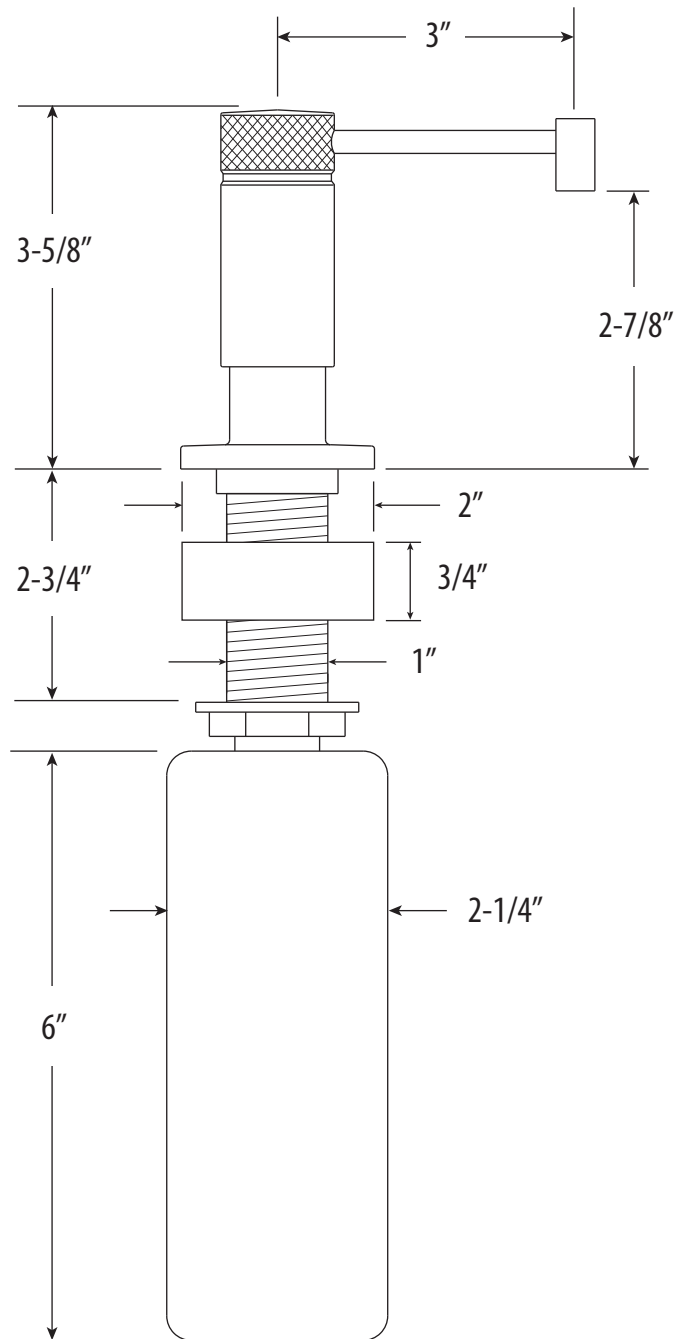

DIMENSIONS MAY VARY AND ARE SUBJECT TO CHANGE. NO RESPONSIBILITY IS ASSUMED FOR USE OF SUPERCEDED OR VOIDED DATA