

INSTRUCTIONS: Line Voltage Flexrail2™

Safety Instructions:

A qualified electrician must install system only. System is intended for installation in accordance with National Electric Code, local and Federal code specifications.

To reduce the risk of fire, electrical shock and injuries to persons:

1. Read all instructions.
2. Turn off power at main switch before installing or modifying the system.
3. Do not install within six inches of any curtain or combustible materials.
4. Do not install less than 5 feet above a floor.
5. Do not install in damp or wet locations.
6. Do not install concealed, or extended through building walls.
7. Do not attempt to energize anything other than a track light fixture.
8. Do not load rail to more than 20 amps per circuit.

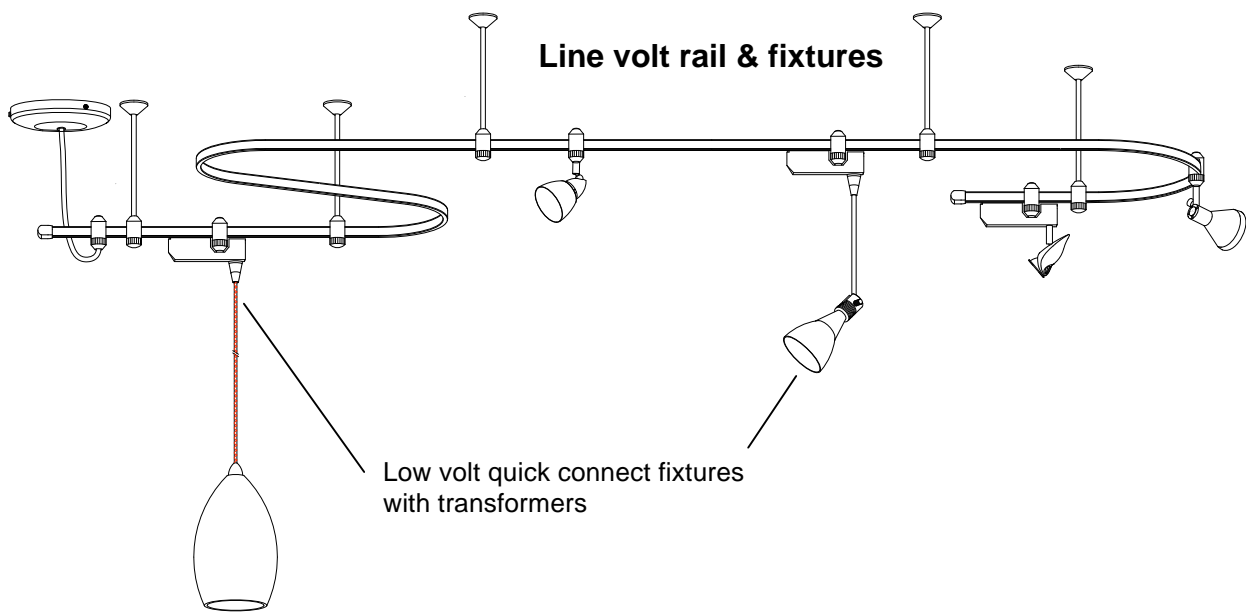

Overview:

WAC line volt Flexrail2™ is a semi rigid plastic rail with available pre bent curved sections. There are five types of fixtures. Line voltage fixtures mount directly on the rail, while low voltage fixtures use a rail mounted electronic transformer. Low voltage fixtures with the quick connect mechanism; allow the use of fixtures and pendants from our low volt monorail series. Metal halide and Compact fluorescent fixtures complete the choices.

Flexrail2™'s two circuits enables the use of two separately controlled circuits on one section or run of rail. Each circuit is rated at 2400 watts (120 V). Mounting the rail to a surface is accomplished by using fixed length standoffs.



Feeding power to canopy:

1. Make sure the rail passes under, or close to a junction box. Power may be introduced at any point along the rail.
2. Loosen the three canopy screws and separate the power feed canopy plate from the base plate.
3. Remove a knock out from the plate and draw wires coming from the canopy through the hole, and into the junction box.
4. Wires from the canopy are four colored. The white wire is the neutral wire to be joined with the white neutral wire from the ceiling.
5. The green wire is the ground wire to be connected with the ceiling ground wire or the junction box itself.
6. A black and red wire remain, these are hot wires. Join the black wire to the black ceiling wire from the first circuit. Join the red wire to the remaining ceiling wire from the second circuit (may be an alternate color or marking).
7. Secure all connections with wire nuts and tuck excess wire back into the junction box.
8. Secure the base plate to the junction box, with two screws through the slotted holes.
9. Secure the canopy to the base plate.

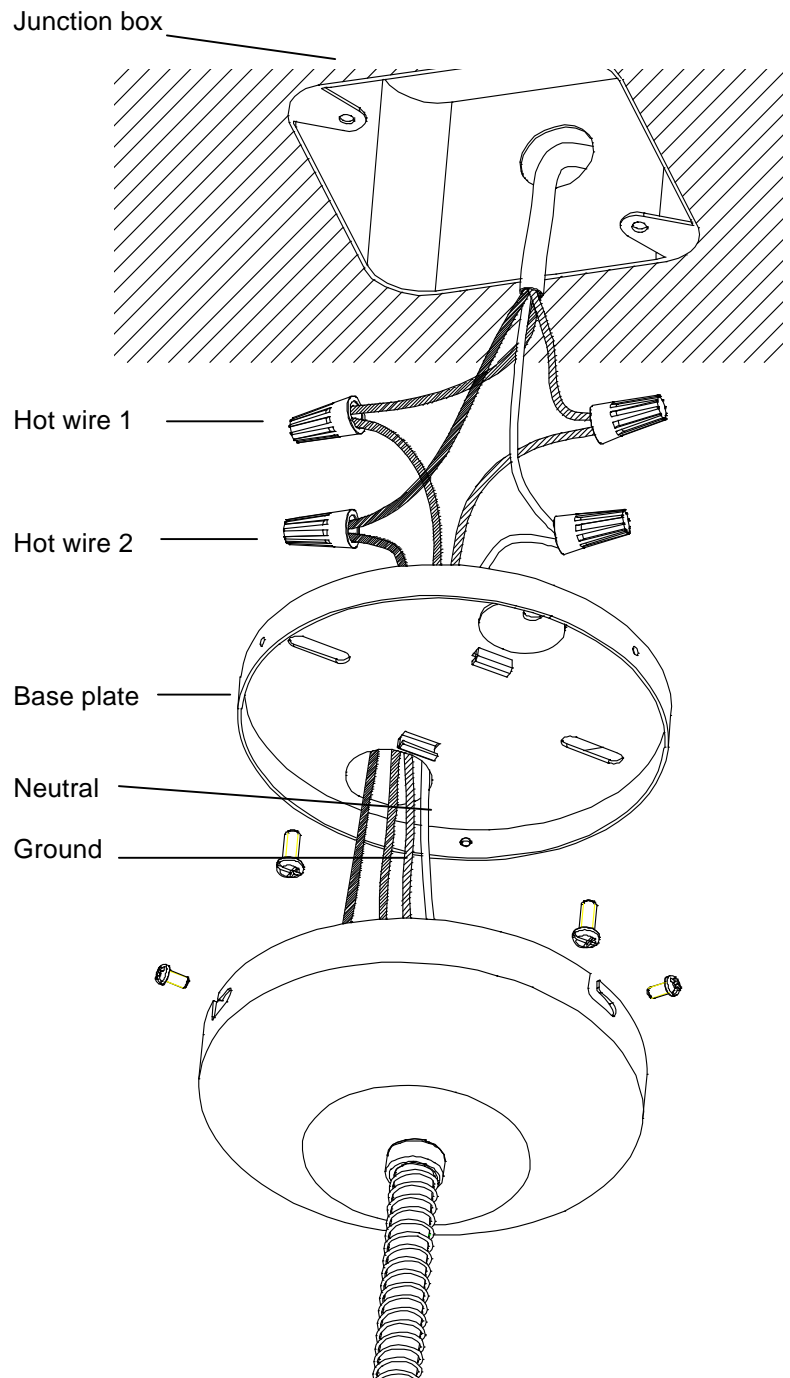

Feeding power to rail:

1. The cable from the power feed canopy goes to the power feed adapter. The adapter is comprised of two cover pieces and an internal adapter. Loosen the cap ring counterclockwise, and slide downwards out of the way.
2. Expose the inside of the adapter by pulling the upper cover up and, remove it completely.
3. Note that the internal adapter is constructed in two pieces, with $\frac{1}{4}$ inch of play between the two. Apply tension to keep the two adapter parts separated so that the metal contacts are mostly hidden.
4. The open end of the adapter is now in the correct position to be pivoted on to the rail.
5. Plant the top side first and pivot the lower end in.
6. Once mounted push the cap ring upward and visually check that the contacts seat in the rail grooves.
7. Replace cap ring and upper sleeve in the order they were removed.
8. Power may be fed anywhere along the length of rail.

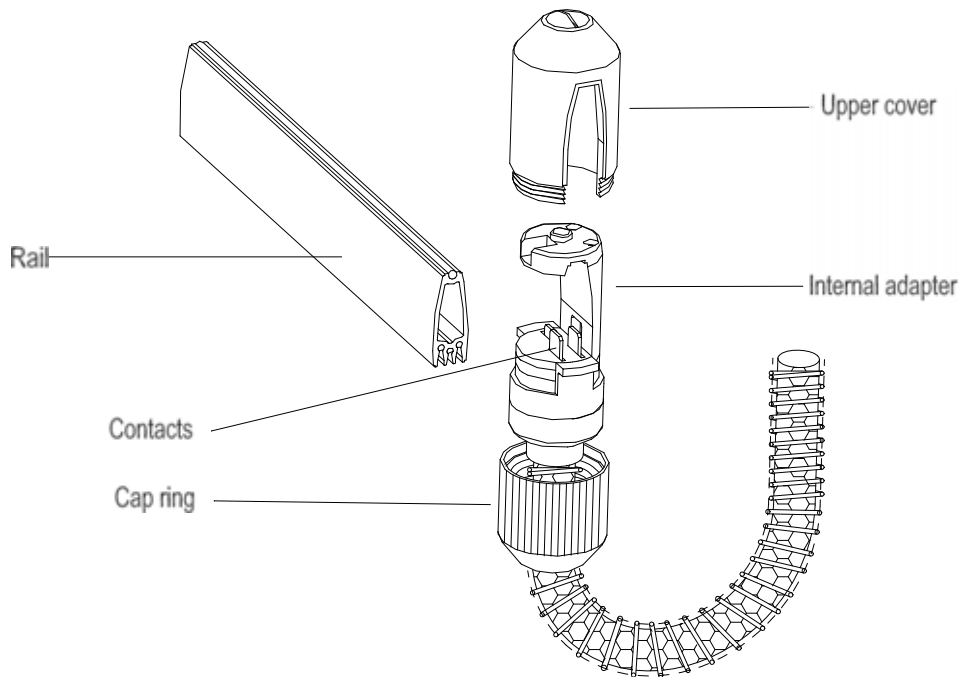

Wiring Options

Option 1:

Two separate circuits controlled by two switches. Rated for 3 wire two circuit 120/240V 60 Hz, single phase with grounded neutral. Maximum 2400 watts per circuit. Total capacity of rail 4800watts.

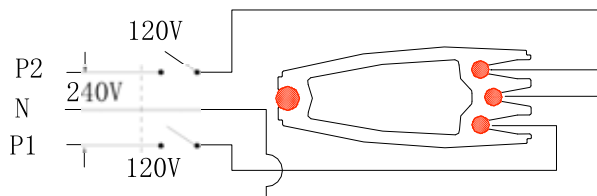

Option 2:

One circuit controlled by two switches. Rated 120V 60Hz 2400watts max. Total capacity of rail 2400 watts.

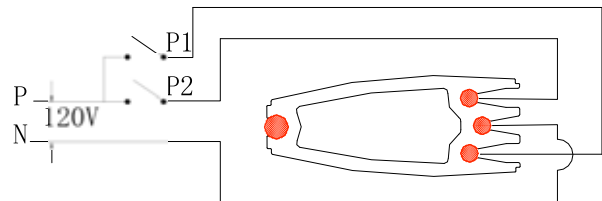

NOTE : Dimming Two circuit rail requires grounded neutral type dimmer switches.

Rail mounting:

Rail can be mounted on a flat surface, a sloped ceiling, or a suspended ceiling.

1. Use three standoffs for every 8ft of straight rail (support every 42"). Curved rail requires more supports. Field curved track sections should be supported every 32". If using heavy elements such as pendants, or ballasted fixtures place a support not more than 8" from the fixture mount (see diagram below).
2. Assemble rail at floor level then, raise to ceiling and mark standoff locations.
3. If rail cannot be raised, use a plumb line to mark standoff locations.
4. **For drywall**, drill 5/8" holes and insert ceiling anchors (supplied) through the bases of the standoffs and then into the ceiling (shown) tighten until snug. **For wood** surfaces use wood screws through the standoff bases and fully tighten.
5. **For "T" bars** (It is recommended that bars be reinforced with Caddy8 clips to the ceiling structure) Twist "T" bar clip onto the "T" bar, then proceed to step 6. For support at a ceiling panel install a support frame between two T-bars.
6. Install the standoff shaft into the base by threading clockwise.
7. Unscrew the cap from the bottom of the rail adapter. With the adapter now open, raise the rail into position and re-install the cap.
8. Work from the center outward. Repeat procedure for remaining standoffs.

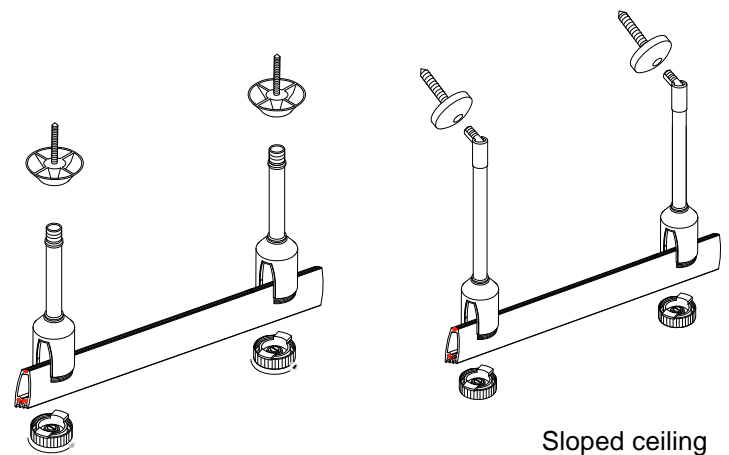

Flat ceiling

Sloped ceiling

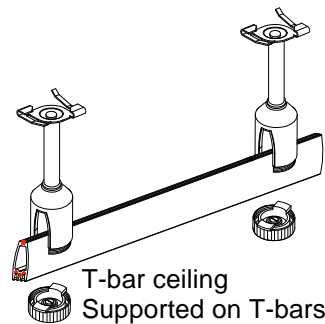

T-bar ceiling
Supported on T-bars

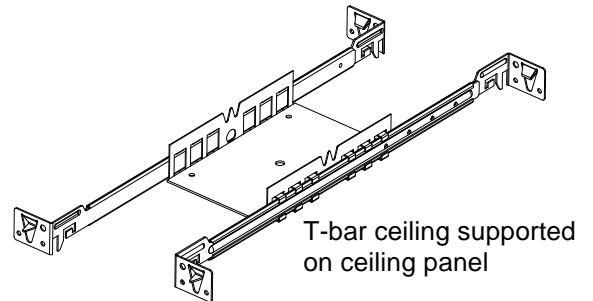

T-bar ceiling supported
on ceiling panel

Sufficient standoff support
within 8" of fixture attachment

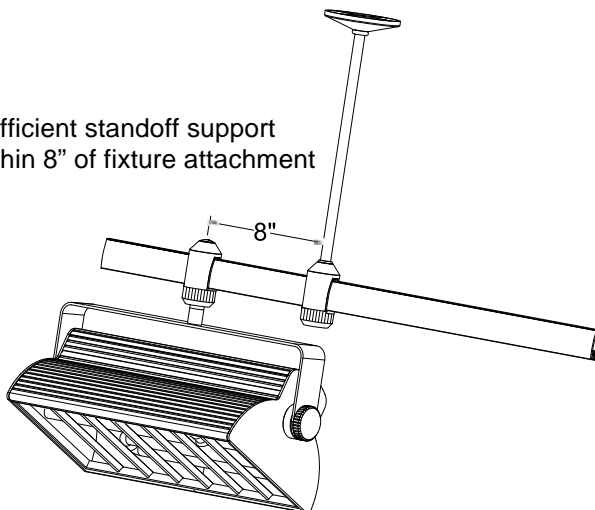

Bending Flexrail2™:

Rail can be bent in the field to achieve various curves. The recommended minimum radius for field bending is a 23" radius". Pre-bent sections are available in 30, 45, 60 and 90-degree angles. A bending tool specific to Flexrail2™ is available, contact your WAC distributor.

1. Before bending: If rail is to be cut and connected to another rail, the end space from the aluminum core must be maintained to accept an "I" connector. Tap the core out with a hammer and cut, so that at least a 7/8" recess will remain after bending. It is OK to cut the core a little short, as it's function is only to help maintain the bend memory.
2. If hand bending, bend the rail a little at a time starting from the mid point.
3. Work the rail in stages until you reach the desired bend.
4. Once rail is bent the wires inside are regressed from the ends. If no other rails are to be connected, install end caps.
5. If rail is to be connected to another rail, it is necessary to cut each end flush. This ensures the bus wires will make proper contact with the connector. (see field cutting).

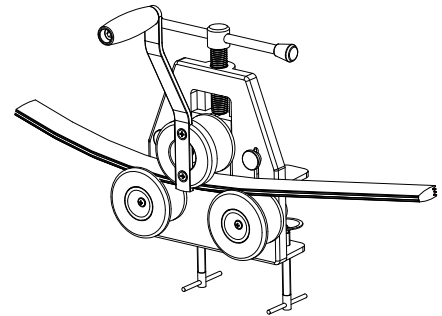

Bending tool

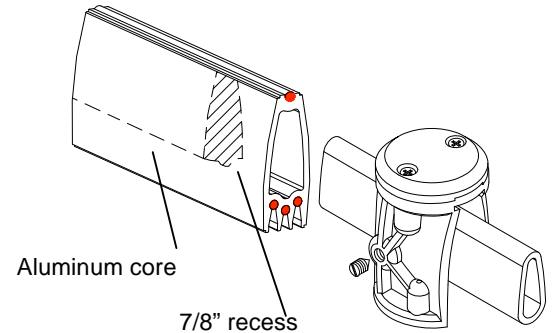

Aluminum core

7/8" recess

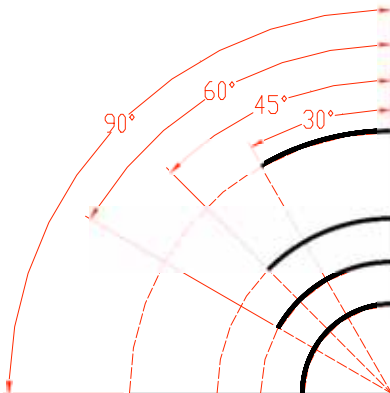

PRE-BENT SECTIONS

NOMINAL RADIUS	NOMINAL CIRCLE DIAMETER	NOMINAL MAXIMUM OVERALL LENGTH	TO BUILD A CIRCLE
36" RADIUS	72" DIAMETER	22"	12 PIECES
24" RADIUS	48" DIAMETER	22"	8 PIECES
18" RADIUS	36" DIAMETER	22"	6 PIECES
12" RADIUS	24" DIAMETER	22"	4 PIECES

Field Cutting:

1. A chop saw produces the cleanest cuts, and is recommended; a fine tooth hacksaw may also be used.
2. Brush out any remaining metal or plastic debris.
3. If the rail is a stand-alone piece, or if this is the end of the rail run, just install an end cap.
4. If rail is to be connected to another rail, continue with instructions for (joining rail).

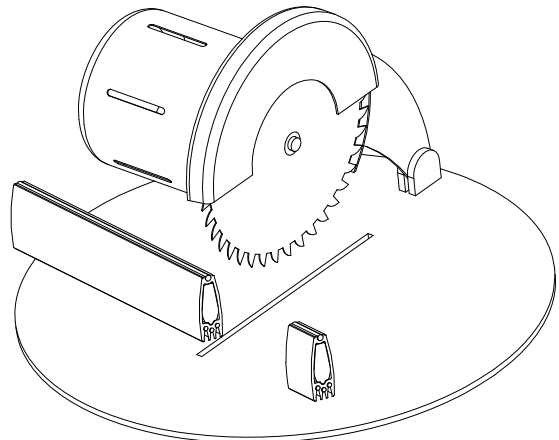

Joining rails:

1. If rail is to be cut and connected to another rail, the end space from the aluminum core must be maintained, to accept an "I" connector. Tap the core out with a hammer and cut, so that at least a 7/8" recess will remain. It is OK to cut the core a little short, as it's function is only to help maintain the bend memory.
2. Loosen other rail supports to allow some movement of the rail.
3. Mount standoff to ceiling surface (see mono rail mounting).
4. Unscrew the cap ring, and withdraw the internal adapter by pulling straight down.
5. The two bottom screws on the internal adapter are supplied loose to allow clearance between the rail and the contacts.
6. Holding the adapter just below upper cover, insert the rail into either end of the adapter.
7. Make sure rails are fully inserted, then tighten the setscrews on the front and back of the adapter.
8. Tighten the bottom screws of the internal adapter.
9. Raise the adapter into the upper cover, and secure with the cap ring.
10. Re-tighten all rail supports.
11. Note hand bending the rail often results in the need to cut each end to restore the evenness of the bus wires (see field cutting).

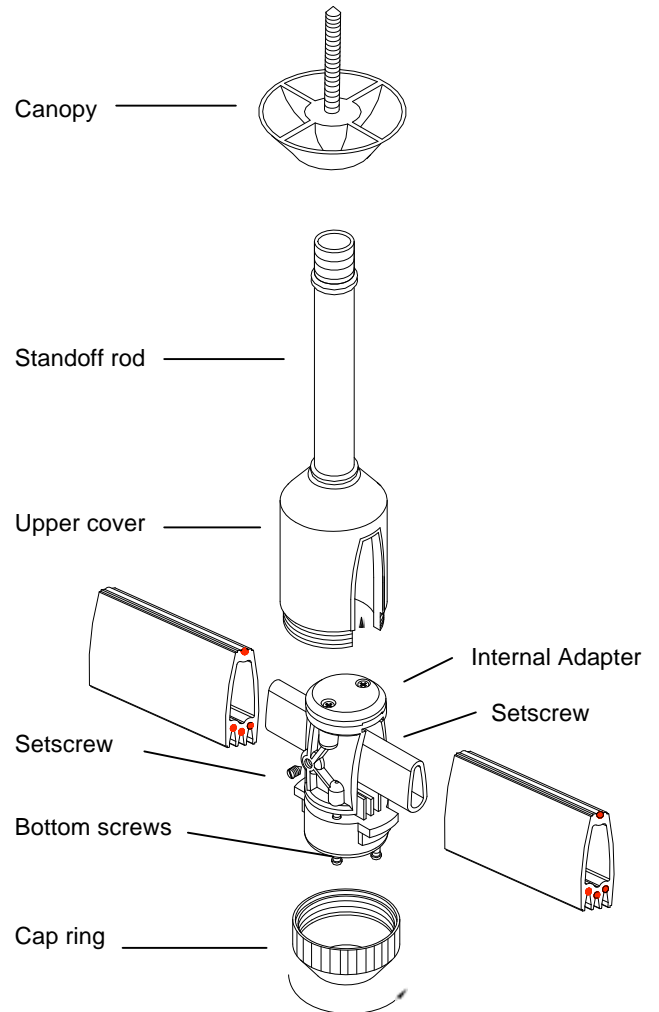
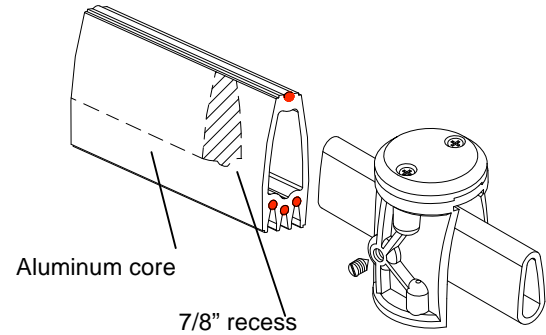

Installing Fixtures:

The fixture adapter is comprised of a cover piece and an internal adapter.

1. Loosen the cap ring counter clockwise, to free the top cover. Pull the cover straight off.
2. Note that the internal adapter is constructed in two pieces, with $\frac{1}{4}$ inch of play between the two. Keep the adapter parts spread so that the metal contacts are recessed.
3. The open end of the adapter is now in the correct position to be pivoted on to the rail.
4. Plant the top end first and pivot the lower end in.
5. Once mounted squeeze the two adapter parts and visually check that the contacts seat in the rail grooves.
6. Replace cap ring and upper cover in the order they were removed.

Note: Installing the fixture from the reverse side engages the second circuit.

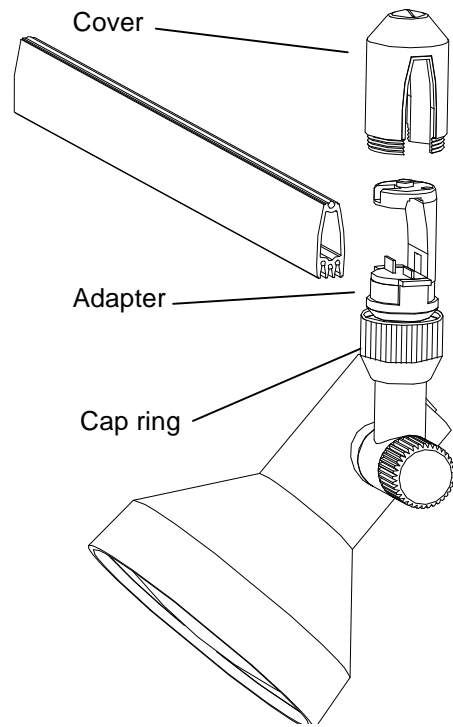

Installing low volt fixtures

Low volt fixtures differ in that they have integral 12v electronic transformers. The adapter is nested inside the transformer housing. The cap ring is a larger diameter than the transformer to allow easy threading. Follow the steps outlined above.

Installing quick connect low voltage fixtures

Quick connect low voltage fixtures employ the same integral 12V electronic transformers as the low voltage fixtures mentioned above. They feature a quick connect nipple that allows "push and turn" attachment of a fixtures and pendants from the low volt Monorail series.

Installing the quick connect:

1. Insert the post of the quick connect into the quick connect adapter.
2. Thread the top half of the conical section until it seats with the adapter.
3. Adjust fixture position, use caution not to

