

USER'S MANUAL

for VCS Series*

Gas Barbecue Grills

(Propane & Natural Gas)

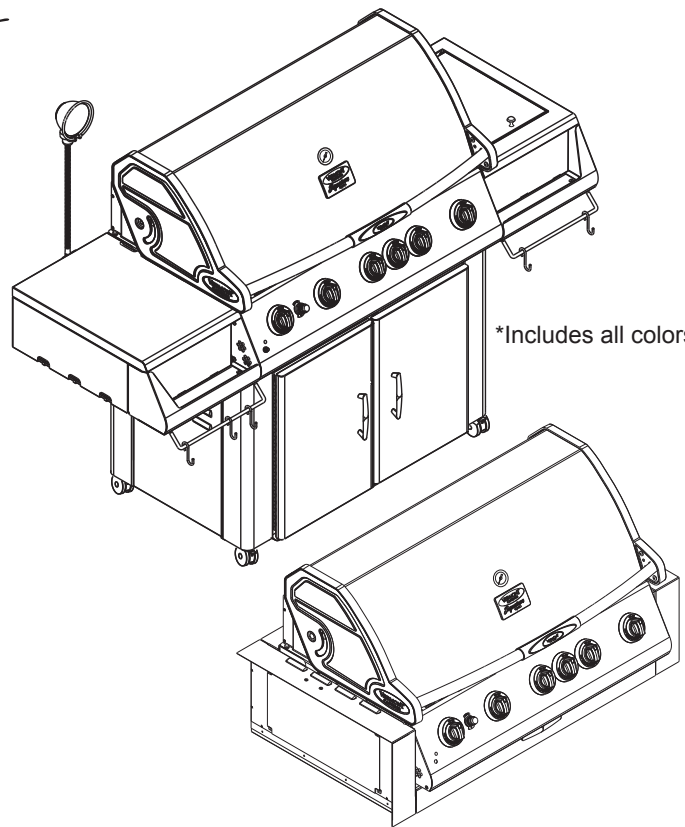

DANGER

If you smell gas:

1. Shut off gas to the appliance.
2. Extinguish any open flame.
3. Open lid.
4. If odor continues, keep away from the appliance and immediately call your gas supplier or fire department.

Failure to follow these instructions could result in fire or explosion which could cause property damage, personal injury or death.



WARNING

1. Do not store or use gasoline or other flammable liquids and vapors in the vicinity of this or any other appliance.
2. An LP cylinder not connected for use shall not be stored in the vicinity of this or any other appliance.
3. Do not operate barbecue without the grease pan installed.

- This instruction manual contains important information necessary for the proper assembly and safe use of the appliance.
- Read and follow all warnings and instructions before assembling and using the appliance.
- Follow all warnings and instructions when using the appliance.
- Keep this manual for future reference.



WARNING: Grills may only be converted from Propane to Natural Gas or Natural Gas to Propane when using a certified conversion kit.

Table of Contents

Table of Contents	2
Parts Identification	3
Safety	
Important Warnings	4
Clearance Requirements	5
Safety	6
Fuels.....	9
Gas Hookup	
Connecting the Gas Supply	11
LP Gas Supply Connection	11
Natural Gas Supply Connection	12
Test for Leaks	12
Operation	
Control Functions	13
Lighting the Main Burners	14
Turning the Burners Off	15
Flare-ups	15
Match Lighting the Main Burner	15
Lighting the Rotisserie Burner	16
Match Lighting the Rotisserie Burner	16
Rotisserie Setup	17
Lighting the Side Burner	18
Lighting the Sear Burner.....	18
Shutting the Side Burner Off	19
Cooking	
Methods of Cooking	20
Preparing Food for the Grill	21
Grilling Tips	22
Cooking Time Chart	23
Care & Maintenance	
Burners	26
Rotisserie Burners	27
Side Burners	27
Cooking Grids.....	27
Drip Tray	28
Stainless Steel Panels	28
Porcelain Enamel Castings	28
Burner Adjustment.....	29
Troubleshooting Guide	30
Warranty	32

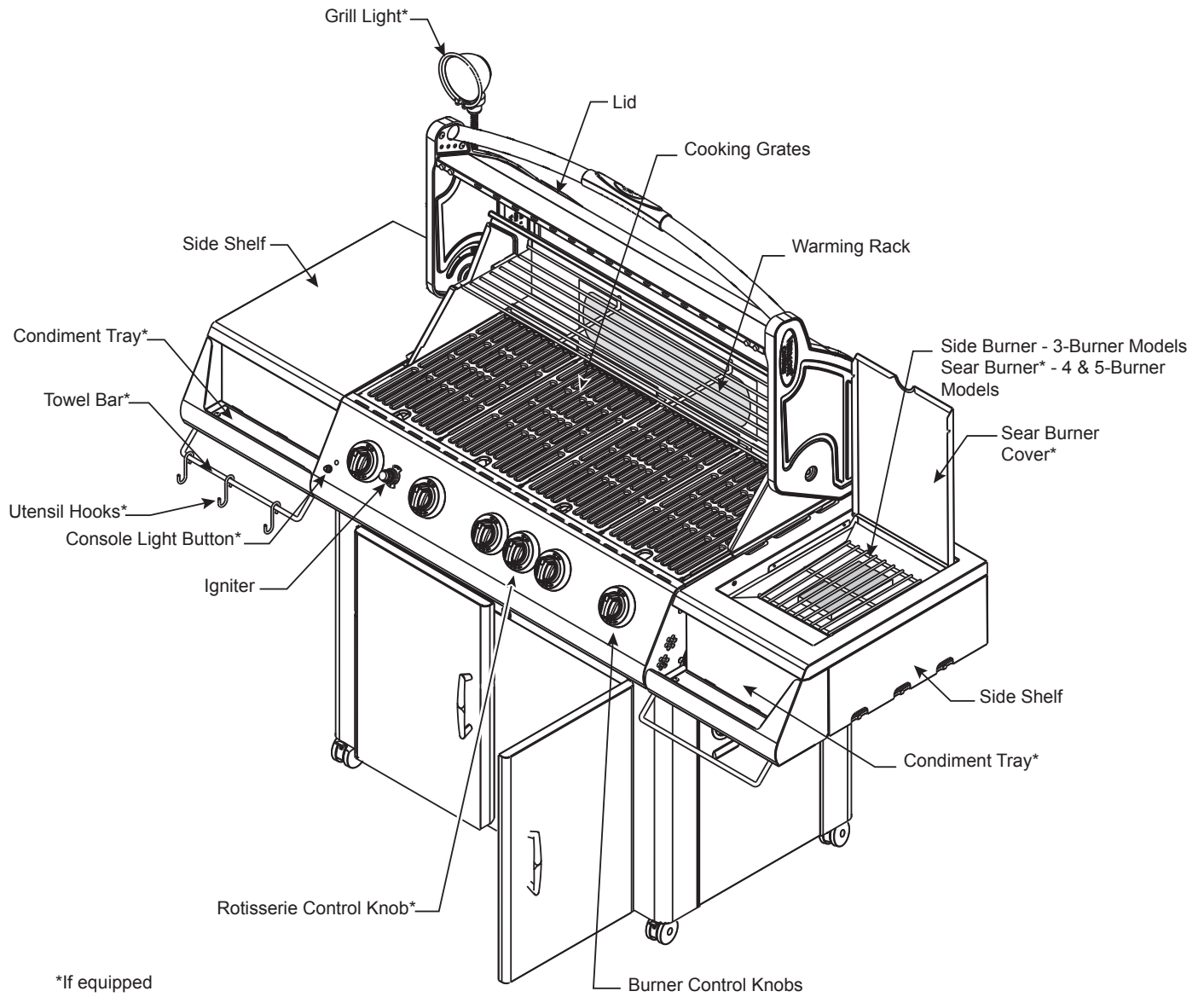

*If equipped

5-Burner Model Shown

Warnings

This Gas Barbecue Grill will provide you with many hours of pleasure and enjoyment, if it is used in accordance with the Warnings and Operating Instructions contained in this Manual.

 Always comply with all of the Warnings and Operating Instructions contained in this manual to prevent personal injury or property damage.

SIGNAL WORDS:

The Signal Words used in this Manual, and their intended meanings, are as follows :

DANGER: Indicates that a failure to observe the safety instructions could result in death or catastrophic bodily injury.

WARNING: Indicates that a failure to observe the safety instructions could result in serious bodily injury.

CAUTION: Indicates that a failure to observe the safety instructions could result in property damage or minor bodily injury.

NOTICE: Designates important information relating to the safe use of the Grill.

IMPORTANT WARNINGS:

Since this outdoor cooking appliance is movable, is fueled by natural or propane gas, generates very high temperatures for cooking and emits carbon monoxide as a by-product of combustion, prudent precautions must be taken to assure its safe use.



- This Grill has been designed for OUTDOOR use only.

Never use this outdoor Grill inside any building, garage, shed, breezeway, or any other enclosed area, to prevent a possible fire and to prevent the possibility of carbon monoxide poisoning or asphyxiation.

This outdoor cooking gas appliance is not intended to be installed in or on boats (any vessels).

This outdoor cooking gas appliance is not intended to be installed in or on recreational vehicles.

This outdoor cooking appliance is not for commercial use.

- Exposing an overfilled or a disconnected propane cylinder to heat could cause venting of fuel through the pressure release valve. Since propane vapor is heavier than air it tends to pool and, if ignited, could produce a violent fire or explosion.

Never install a propane cylinder in this grill if it is more than 80% full, as the contents may lack adequate room for expansion when exposed to heat.

Never store a spare Propane Gas Cylinder in the cylinder-compartment of this Grill, because it will be exposed to high temperatures when the Grill is in use.

The use of alcohol, prescription or non-prescription drugs may impair the ability to properly assemble or safely operate this appliance.

This appliance is not intended for and should never be used as a heater.

The essential Warnings and Safety Instructions are located throughout the pages of this Manual, but some of the principal ones have been summarized as follows for your convenience:

A. SAFE LOCATIONS FOR USE OF THIS OUTDOOR GRILL

DANGER

- **Never install a free-standing outdoor propane Grill in an “island” configuration**, (i.e. where it is enclosed in any type of construction), to prevent a fire or gas explosion.
- **Never use this outdoor Grill inside any building, garage, shed or breezeway, or inside any boat, trailer or recreational vehicle**, to prevent a possible fire and to prevent the possibility of carbon monoxide poisoning or asphyxiation.
- **Never attempt to light the Grill while the lid is closed**, to prevent the accumulation of gas and a possible fire or explosion.
- **Never stand directly over the Grill while lighting it to avoid exposure to a possible flare-up.**

WARNING

- **Always confirm that this Grill is not positioned under a combustible object** (e.g., an awning or umbrella) or in a covered area (e.g., a porch or gazebo) before lighting it, to prevent a possible fire.
- **Always confirm that this Grill is not positioned under the overhang of a house, a garage or other structure** before lighting it. An overhang will serve to deflect flare-ups and radiated heat into the structure itself, which could result in a fire.
- **Always confirm that this Grill is positioned more than 36” (914 mm) away from any combustible materials or surfaces** before lighting it, and that no gasoline or other volatile substances are stored in the vicinity of this Grill. The temperature of a grease fire or of the radiated heat might otherwise be sufficient to ignite nearby combustibles or volatile substances.
- **Always locate this Grill where there will be ample combustion and ventilation air**, but never position it in the direct path of a strong wind.
- **Never allow the Grill to operate while unattended**, to prevent uncontrolled grease fires from erupting.
- **Never attempt to move this Grill while it is in operation** or while it is still hot, to prevent possible personal injury.
- **Never store or use gasoline or other flammable or volatile substances** in the vicinity of this Grill or in the vicinity of any other heat-generating appliances, because of the danger of starting a fire.
- **Always confirm that the installation of this Grill conforms with the requirements of all local Codes** or, in the absence of any applicable local Codes, with either the *National Fuel Gas Code, ANSI Z223.1/NFPA54, Storage and Handling of Liquefied Petroleum Gases, ANSI/NFPA 58; or Natural Gas and Propane Installation Code, CSA B149.1; Propane Storage and Handling, CSA B149.2.*

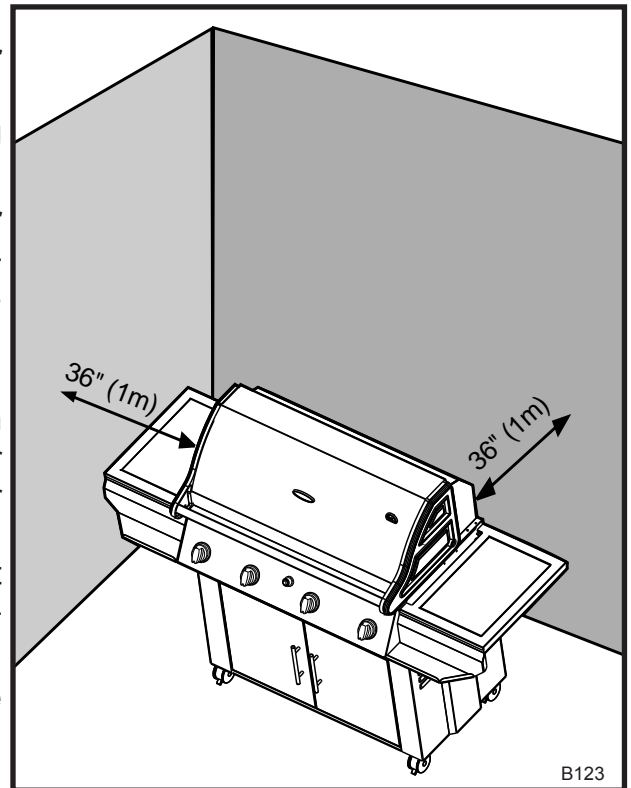

B. SAFE USE OF PROPANE (LP) GAS

DANGER

- Never install a propane cylinder that is more than 80 % full, as the contents may lack adequate room for expansion when exposed to heat. Propane vapor may then be vented through the pressure release valve, which could accumulate in a pool and later result in a fire or explosion.

Always instruct your certified propane fuel supplier to confirm by weight that your cylinder is not more than 80 % full. An empty cylinder will weigh about 19 lbs., while a properly filled cylinder should weigh no more than 39 lb.

- Never store a spare Propane Cylinder in the cylinder-compartment of this Grill. Exposing a disconnected cylinder to heat could result in the venting of propane vapor through the pressure release valve, and the resulting pooled vapor could cause a violent fire. (No hazard is posed by the connected cylinder if it is not overfilled, however, as it tends to refrigerate itself while it is being used.)

Always confirm that all openings in the cylinder compartment of this Grill are free of any obstructions that would restrict the circulation of ventilation air. Good ventilation will prevent any leaked propane vapor (which is heavier than air) from pooling. Pooled propane vapor is a hazard, as it could explode if ignited.

- Always store your spare Propane Gas Cylinders in an outdoor area that is well-ventilated, shady, cool and removed from any heat source. Always store those cylinders in an upright position. Never store a spare cylinder in the vicinity of this Grill, or in the vicinity of any other heat-generating appliance.

WARNING

- Always consult the Rating Label on the back of the Grill to confirm which fuel must be used with the Grill. Never operate the Grill with propane gas if it has been configured to use natural gas, to prevent hazardous overheating.
- Always confirm that there are no gas leaks before lighting this Grill. Turn on the main gas valve while the burner valves are set to the “OFF” position. Apply a 50/50 solution of liquid soap and water to the gas supply line connectors with a brush or spray bottle, and watch for bubbles. If bubbles appear, a leak is indicated.
- Turn off the gas supply and repair the leak. Repeat this test until no bubbles appear. Never use a match or open flame to test for gas leaks.
- Always visually inspect the gas supply line for fraying, cracking or rodent damage before each use of this Grill. If necessary, install a replacement hose and regulator obtained from the manufacturer before lighting this Grill. This procedure requires the opening of a door (or doors) in the Grill.

C. SAFE USE OF NATURAL (NG) GAS

WARNING

- Always consult the Rating Label on the back of the Grill to confirm which fuel must be used with the Grill.
- Never attempt to operate the Grill with natural gas if it has been configured to use propane gas, and never attempt to use propane gas if it has been configured to use natural gas, to prevent possible bodily injury.
- Always employ a qualified service agency to install all necessary natural gas supply plumbing, for safety reasons and to assure compliance with all applicable Codes.

C. SAFE USE OF NATURAL (NG) GAS (continued)

WARNING

- Always promptly shut off the gas supply and immediately extinguish all flames if you smell gas.
- Always seek assistance from your gas supplier or your local Fire Department if the gas smell persists, because of the danger of fire or explosion.
- Always confirm that there are no gas leaks before lighting this Grill. Apply a 50/50 solution of liquid soap and water to the gas supply line connectors with a brush or spray bottle, and watch for bubbles. If bubbles appear, a leak is detected.
- Turn off the gas supply and repair the leak. Repeat this test until no bubbles appear. Never use a match or open flame to test for gas leaks.
- Always visually inspect the gas supply line for fraying, cracking or rodent damage before each use of this Grill. If necessary, install a replacement before lighting this Grill. This procedure requires the opening of a door or doors in the Grill.
- Keep the fuel supply hose away from any heated surface(s).

D. PREVENTION OF BURNS

WARNING

- Always keep children and pets under close supervision when using this Grill, and never permit them to come near the Grill while it is in use, as the exterior surfaces will be extremely hot.
- Always wear insulated protective mitts when working at the Grill, or when attempting to close a gas supply valve after cooking has been completed, to prevent possible burns. Always use insulated pot holders when handling containers of hot food.
- This appliance will be hot during and after use. Use insulated oven mitts or gloves for protection from hot surfaces or splatter from cooking liquids.
- Always wear an insulated protective mitt when adding a smoking agent to a Smoker Box.
- Never store or use gasoline or other flammable or volatile substances in the vicinity of this Grill, or in the vicinity of any other heat-generating appliance.

E. ELECTRICAL SAFETY

WARNING

- Always confirm that this Grill has been grounded in accordance with applicable local Codes or, in the absence of local Codes, with the National Electrical Code, ANSI/NFPA No. 70 or the Canadian Electrical Code, CSA C22.1, when an external electrical source is being utilized for the Rotisserie Motor.
1. Never immerse the power cord or power plug in water, or in any other liquid to protect against electric shock;
 2. Always unplug the power cord from the outlet when not in use, and before cleaning the Grill. Always allow the unit to cool before installing or removing any Rotisserie components;
 3. Always contact the manufacturer for necessary repair services, if the unit has malfunctioned or has been damaged in any manner, and never attempt to operate the unit with a damaged power cord or power plug;
 4. Never allow the power cord to contact a hot surface or to hang over the edge of a table, where it might sustain damage;
 5. Never use this Grill for any purpose other than the ones specifically intended by the manufacturer;
 6. Always connect the power cord to the Grill first, and then plug it into the power outlet;
 7. Always connect this Grill to an electrical circuit protected by a Ground Fault Interrupter (GFI);
 8. Never remove the 3-pronged (grounded) power plug from the existing Rotisserie Motor power cord, and never connect the 3-pronged (grounded) power plug to a 2-pronged adapter.
 9. If it is necessary to use an extension cord, always select one that has a 3-pronged (grounded) power plug; that is adequate for the power rating of the unit; and that has been approved for outdoor use, and has a W-A marking.
 10. Keep any electrical supply cord and the fuel supply hose away from any heated surface.
 11. Electrical Grounding Instructions: This outdoor cooking gas appliance is equipped with a three-pronged (grounding) plug for your protection against shock hazard and should be plugged directly into a properly grounded three-pronged receptacle. Do not cut or remove the grounding prong from this plug.

F. BATTERY HANDLING

WARNING

Replacing the battery incorrectly might result in an explosion. Replace the battery only with the same or equivalent type recommended by the manufacturer. Dispose of used batteries according to your local environmental guidelines.

PROPANE GAS FUEL

⚠️ WARNING

Never use Natural Gas in a Grill that has been configured to burn Propane Gas, (and never use Propane Gas in a Grill that has been configured to use Natural Gas) to avoid possible bodily injury. Always consult the Rating Label on the back of the Grill to confirm that it has been configured to burn Propane Gas.

Always install the pressure regulator and Type 1 propane gas supply coupling and hose that has been provided with your Propane Grill, as pictured in Figure 2.

- Always install a standard 20 lb. propane cylinder that has been equipped with a Type I valve outlet as shown in Figure 3, and that is 12" in diameter and 18" in height. Always use a propane cylinder that has been constructed and marked in conformance with either the specifications for LP Gas Cylinders of the U.S. Department of Transportation or the specifications in the National Standard of Canada, CAN/CSA-B339, Cylinder, Spheres and Tube for Transportation of Dangerous Goods, as applicable.

- Always confirm that your propane cylinder is equipped with a shutoff valve terminating in a Type I propane cylinder valve outlet connection, and that it has been provided with a collar to protect the cylinder valve.
- Never install a propane cylinder in this Grill unless it is equipped with a listed Overfill Protection Device (OPD).
- Always have a new propane cylinder properly purged of air by your certified propane gas dealer. Since a new cylinder is initially filled with air, the air must first be purged before it is filled with propane.
- Always visually inspect the gas supply line for fraying, cracking or rodent damage before each use of this Grill and, if necessary, install a replacement hose and regulator obtained from the manufacturer prior to lighting this Grill.

- Always place a dust cap on the cylinder valve outlet whenever the cylinder is not in use and always install the dust cap that was provided with the cylinder valve. The use of an incorrect dust cap could result in leakage of propane.

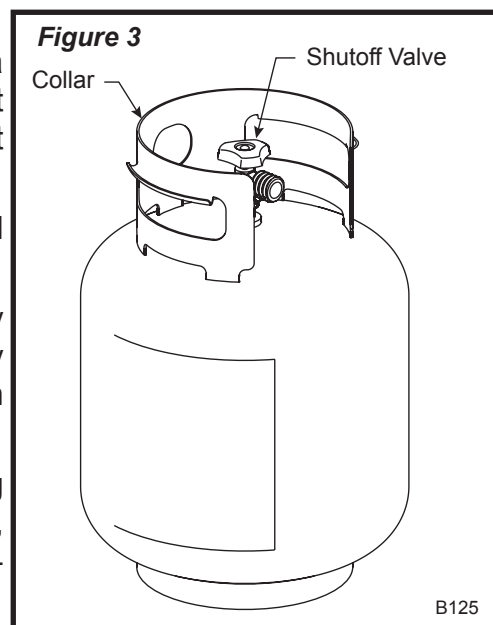
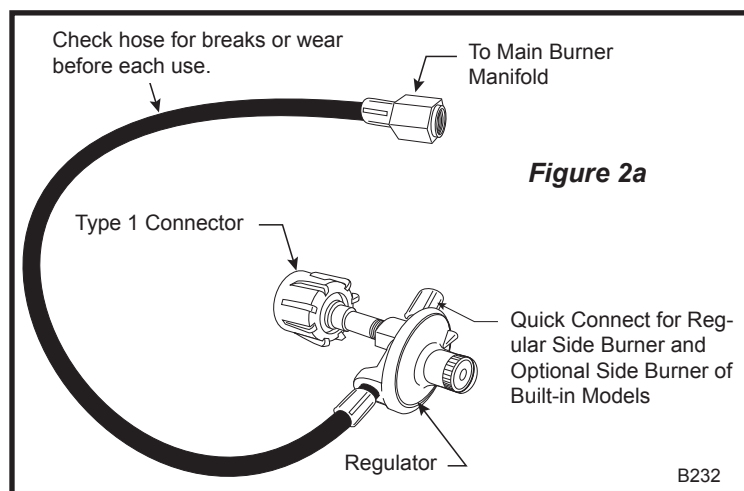
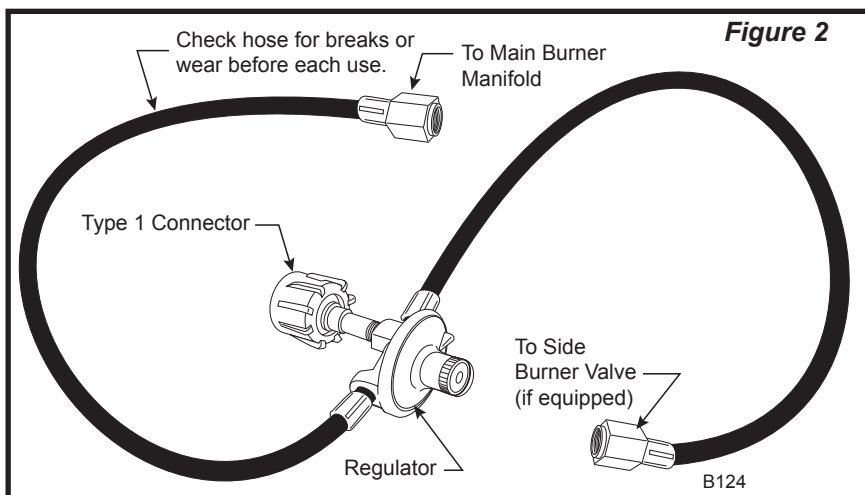

PROPANE GAS FUEL (continued)

DANGER

Never install a freestanding outdoor propane Grill in an “island” configuration, (i.e. where it is enclosed in any type of construction), to prevent a fire or gas explosion.

- a) Never store a spare LP - Gas Cylinder under or near this appliance
- b) Never fill the cylinder beyond 80% full; and
- c) Always comply with these warnings, to prevent a fire causing death or serious injury.

WARNING

Always confirm that all opening in the cylinder-compartment of this Grill are free of any obstructions that would restrict the circulation of ventilation air. Good ventilation will prevent any leaked propane vapor (which is heavier than air) from pooling. Pooled propane vapor is a hazard, as it could explode if ignited.

- **Always handle propane cylinders with great care, as the contents are under high pressure.**
- **After first closing the grill control knob on the grill console, always close the propane cylinder valve promptly after each use of the Grill.**
- **Always store propane cylinders outdoors, in an upright, secure position, out of direct sunlight, away from living quarters and in a well-ventilated, cool, dry area.**
- **NEVER STORE A CYLINDER IN A BUILDING, GARAGE OR OTHER STRUCTURE OR ENCLOSED AREA.**
- **Always keep cylinders out of reach of children.**
- **Always confirm that a valve dust cap has been tightly installed and that the valve itself is fully closed, whenever a propane cylinder has been disconnected.**
- **Always transport a propane cylinder in an upright, secure position, after confirming that its valve is closed.**
- **Always stabilize a cylinder so that it cannot move, when it is being transported in a car trunk.**
- **Never transport a propane cylinder in the passenger compartment of a car or truck.**
- **Never store a Gas Grill indoors, unless the propane cylinder has first been disconnected and removed from the Grill.**
- **Never expose a propane cylinder to any heat source and never apply heat directly to a cylinder.**
- **Never store a spare cylinder in the vicinity of this Grill.**
- **Never paint a propane cylinder a dark color, as this can cause the cylinder and its contents to overheat.**
- **Always install the LP cylinder in an upright position with the valve at the top, to facilitate vapor withdrawal, as shown in Figure 3.**

NOTICE

Always have a certified propane gas supplier inspect and re-qualify your refillable propane gas cylinder prior to each refilling, in accordance with DOT or TC requirements for propane cylinders.

Connecting the Propane (LP) Gas Supply

CONNECTING THE GRILL TO A PROPANE (LP) GAS CYLINDER

1. Always secure the propane tank in the tank locator hole in the bottom pan of the cylinder-compartment. (Portable gas grill only.)
2. Always confirm that all burner control knobs are in the OFF position before activating the gas supply.
3. Always connect the gas supply regulator by first inserting the nipple of the valve coupling into the tank valve and then tightening the connection collar by turning it clockwise with one hand while holding the regulator with the other as shown in Figure 4.

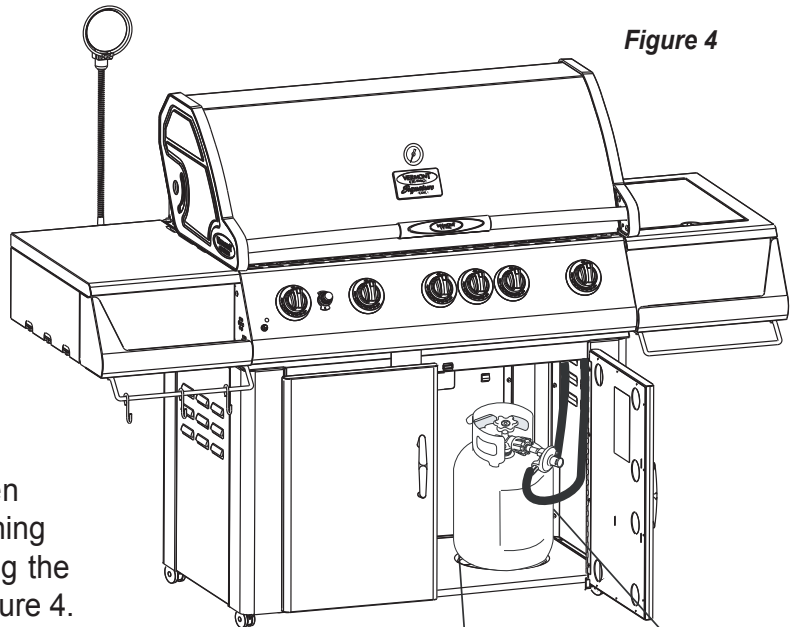
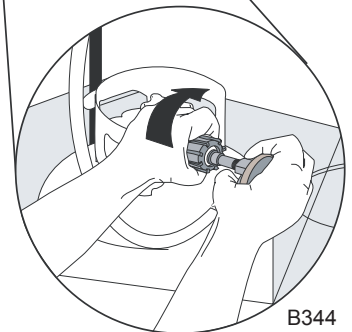

Figure 4

WARNING

Always conduct the gas leak test described on Page 12 before attempting to light this Grill, to prevent a possible fire or explosion.

1. Never store or use gasoline or any other volatile substance in the vicinity of this Grill.
2. Never store a spare propane cylinder in the vicinity of this Grill, or in the vicinity of any other potential heat source.



B344

NOTICE

Always consult your local gas supplier for professional assistance before attempting to connect this Grill to a fixed pipe bulk Propane (LP) gas supply system.

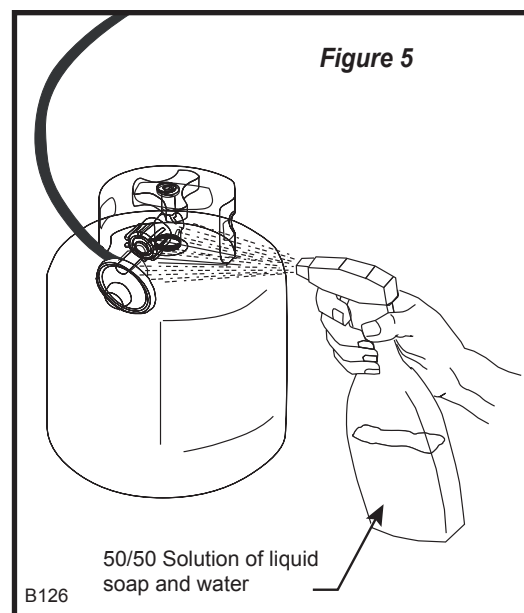

Figure 5

50/50 Solution of liquid soap and water

B126

Connecting the Grill to the Natural (NG) Gas Supply

CONNECTING THE GRILL TO THE MAIN GAS SUPPLY

TO CONNECT:

1. Retract the Sleeve on the Socket as shown in Figure 6a.
2. Insert Plug and release the Sleeve. (Fig. 6b)
3. Push the Plug until Sleeve snaps forward to lock the Plug in the Socket.

TO DISCONNECT:

1. Push Sleeve back and pull the Plug out.

WARNING

- Never use Propane Gas in a Grill that has been configured to burn Natural Gas, (and never use Natural Gas in a Grill that has been configured to use Propane Gas), to avoid possible bodily injury. Always consult the Rating Label on the back of the Grill to confirm that it has been configured to burn Natural Gas.
- Always utilize a qualified service agency to perform all required gas supply plumbing. In the U.S., the supply connection must be made in accordance with local code or, in the absence of local codes, with the national fuel gas codes, ANSI Z223.1/NFPA54. In Canada, the supply connection shall be carried out in accordance with the provincial authorities having jurisdiction and in accordance with the requirements of the CSA 1-B149.1 installation code.
- A shutoff valve must be installed between the gas grill and the main supply. For natural gas, use a 3/8" or 1/2" natural gas supply line capable of an input of at least 100,000 BTUs (depending on the model).
- Always disconnect the Grill and close its individual manual shutoff valve, when conducting pressure tests of the gas supply piping system at pressures which exceed 1/2 psi (3.5 kPa).
- Always isolate the Grill from the gas supply piping system by closing its individual manual shutoff valve when conducting pressure tests of the gas supply piping system at pressures equal to or less than 1/2 psi (3.5 kPa).

Always conduct the following test for gas leaks before attempting to light the Grill to prevent a possible fire or explosion:

1. Always confirm that all burner control knobs are in the OFF position.
2. Always connect the gas supply hose first and then open the gas shutoff valve.
3. Always use a brush or spray bottle to apply a 50/50 solution of liquid soap and water to all connection points (as illustrated in Figure 5) to test for gas leaks. Never use a match or open flame for that purpose.
4. Always look for bubbles to appear, as the appearance of bubbles will indicate a gas leak. Always turn off the gas immediately at the gas supply valve and tighten the connection, if you find that a leak exists.
5. Always repeat this procedure until no further gas leaks are found to exist, before lighting the Grill.
6. Never attempt to light this Grill, however, if a leak cannot be stopped. Always call your gas supplier promptly to obtain assistance.

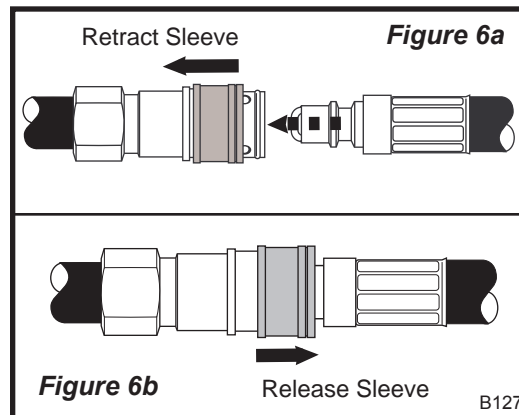

Control Functions

PROPANE TANK VALVE



Always open the Propane Tank Valve immediately before lighting the Grill and always close it immediately after cooking has been completed.



WARNING

Never open the Propane Tank Valve unless the Grill is being prepared for use, to prevent the pooling of propane vapor.

Always open the Valve immediately before lighting the Grill, and always close it immediately after cooking has been completed.

BURNER CONTROL VALVES (Fig. 7)

On VCS32x series, three valves independently control gas flow to each burner and a separate control valve for the rotisserie burner.

On VCS33x series, three valves independently control gas flow to each burner.

On VCS42x series, four valves independently control gas flow to each burner and a separate control valve for the rotisserie burner.

On VCS52x Series, five valves independently control gas flow to each burner and a separate control valve for the rotisserie burner.

The OFF position is indicated above each knob. A full range of flame adjustment is available from High to Low, (by turning a knob counterclockwise).

Activating the Igniter

ELECTRONIC IGNITION SYSTEM

Turn on one or more burner control valves. Push and hold the burner igniter. As you push and hold the Igniter Button, you will hear a series of clicks as the igniter module generates an ignition spark to the burners. The burner should light within five seconds. Depending on which model you have, the system is powered by either a single “AA” or a single “AAA” battery. Ensure the battery has been installed before using the igniter. To remove or replace the battery, turn the push button knob counterclockwise, and carefully pull out the spring and battery. Ensure the positive end of the battery is in the down (bottom) position before replacing the knob.

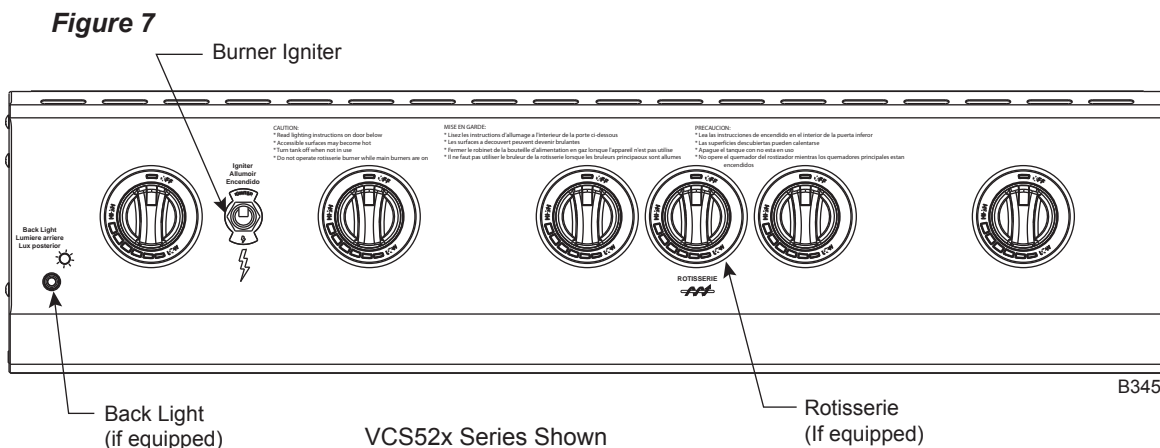

Lighting the Main Burners

WARNING

Never stand directly over the Grill when lighting the main burners, to avoid exposure to possible flare-ups.

1. **Always open the Hood completely and always inspect** the Grill and burners before lighting the main burners.
2. **Always confirm that all of the burner control knobs** are in the OFF position before opening the gas supply.
3. **Turn on the Propane Tank Valve at the tank** (1 to 2 turns) (Fig. 8) or turn on the main natural gas supply valve.
4. **Turn the selected Burner Control Knob to the HIGH** position by pushing down on the knob and turning it counterclockwise.
5. **Immediately activate the Igniter.** (Refer to Page 13)
The selected burner should light within five seconds. Light the burners sequentially from either left to right or right to left.

 **IF THE SELECTED BURNER DOES NOT LIGHT,** immediately turn the burner control knob to the OFF position, to prevent gas buildup. Wait five (5) minutes for the gas to clear and then repeat the preceding starting procedure. If the burner will not light when using the Igniter, follow the match lighting instructions. (Refer to Page 15)

6. Confirm that the burner is properly lit and the flame pattern is as desired. Refer to Figures 9a, 9b & 9c, for the proper flame patterns. If the flame pattern is other than normal, consult the Troubleshooting Guide on Page 30 for corrective action.
7. Always preheat the grill before starting cooking. A light coating of cooking oil on the cooking grids, before heating the Grill, will prevent foods from sticking to the Grill. Light all burners and adjust them to the HIGH position for 5 to 10 minutes. Before placing any food on the Grill, clean the cooking grids with a brass wire brush.
8. Adjust the Controls to a medium setting for most cooking requirements.

NOTICE: When lighting the grill for the first time, burn with the main burners on HIGH for at least 30 minutes, to burn off any manufacturing residues.

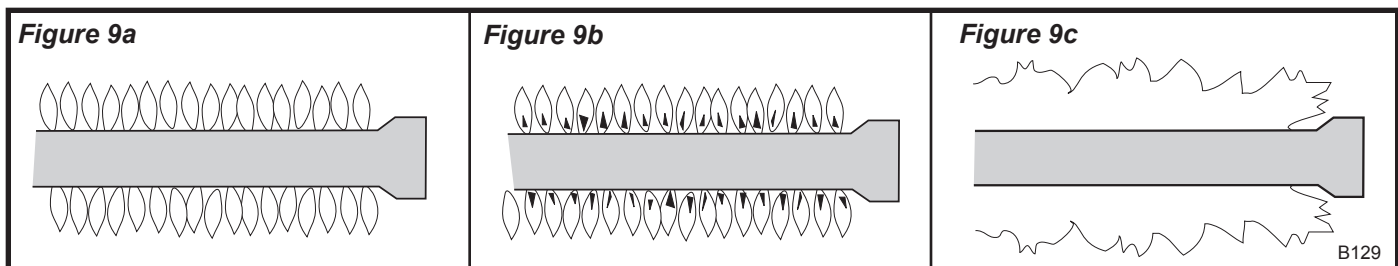
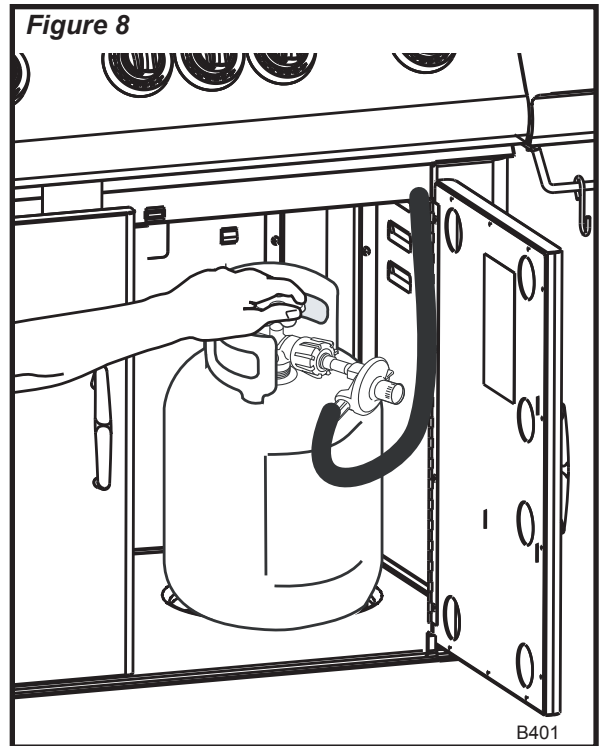

Normal: Soft blue flames

Out of Adjustment: Noisy, hard blue flames indicate too much air

Poor Combustion: Wavy, yellow flames indicate too little air.

Turning the Burners Off

1. Always turn the burner control knob(s) to the OFF position before turning off the main supply valve when cooking has been completed.
2. Promptly turn OFF the gas supply valve at the propane cylinder or at the main natural gas supply line.
3. Close the Hood of the Grill.

FLARE-UPS

“Flare-ups” sometimes occur when food drippings fall onto the hot sear plates or burners and ignite. Some flaring is normal and desirable, as it helps impart the unique flavors associated with grilled foods. Controlling the intensity of the flare-ups is also desirable, however, in order to avoid burned or unevenly cooked foods and to prevent the possibility of an accidental fire.

WARNING

Never allow the Grill to operate while unattended to prevent uncontrolled grease fires from erupting. Always monitor the Grill carefully while cooking and turn the flame level down (LOW), or OFF, if flare-ups intensify.

MATCH LIGHTING THE MAIN BURNERS:

WARNING

Never stand directly over the Grill when lighting the main burners, to avoid exposure to possible flare-ups.

1. a. Always open the Hood completely and inspect the Grill and burners before lighting the main burners.
 - b. Make sure the grease cup is empty and grease tray is clean.
 - c. Always visually inspect the gas supply line for fraying, cracking or rodent damage before lighting the grill and, if necessary, install a replacement obtained from the manufacturer prior to lighting the grill.
2. Always confirm that all of the burner control knobs are in the OFF position before opening the gas supply.
3. Always turn on the propane gas supply valve at the tank (1 to 2 turns) or turn on the main natural gas supply valve.
4. Insert a lit match using the holder provided or a butane lighter into the match lighting hole located on the left hand side of the base. (Fig. 10)
5. Turn the left Burner Control Knob to the HIGH position by pushing down on the knob and turning it counterclockwise.
6. If the burner will not light within five (5) seconds, turn off the gas, wait a few minutes to clear the gas before trying to light the grill again.

 Never store flammable or easily combustible objects (matches, butane lighters, cloths, etc.) in the pull out food warming drawer (if equipped).

Figure 10

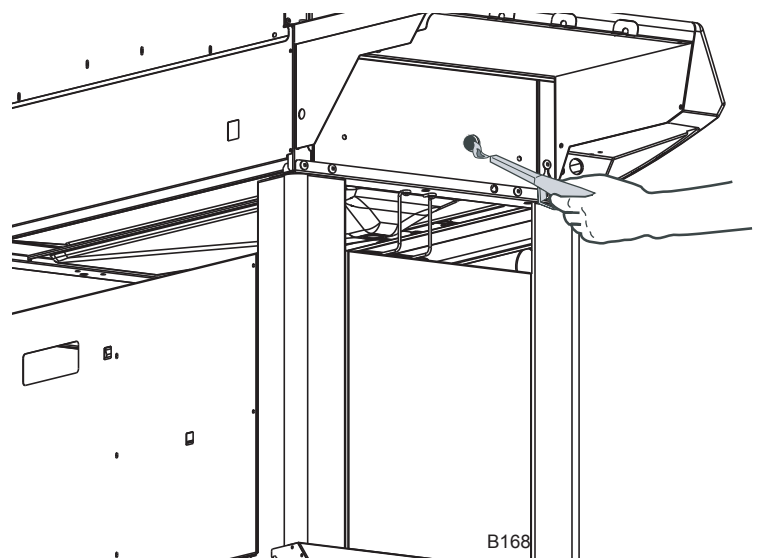

Lighting the Rotisserie Burner (if applicable)

The Rotisserie burner provides the steady, even heat required to cook poultry and roasts to self-basted perfection.

WARNING

Never stand directly over the Grill when lighting the main burners, to avoid exposure to possible flare-ups.

TO START THE ROTISSERIE BURNER:

1. Always open the Hood completely before attempting to light the Grill.
2. Always confirm that all of the burner control knobs are in the OFF position before opening the gas supply.
3. Turn on the Propane Tank Valve at the tank (1 to 2 turns) or turn on the main natural gas supply valve.
4. Turn the Rotisserie Burner Control Knob to the HIGH position, by pushing down on the knob and turning it counterclockwise.
5. Immediately push the Igniter Button. The Rotisserie burner should light within five seconds.

 **IF THE ROTISSERIE BURNER DOES NOT LIGHT**, immediately turn the burner control knob to the OFF position, to prevent gas buildup. Wait five (5) minutes for the gas to clear and then repeat the preceding starting procedure. If the burner will not light when using the Igniter, follow the match lighting instructions below.

6. Confirm that the burner is properly lit and that the flame pattern is as desired. Refer to Figures 9a, 9b & 9c for the proper flame patterns. If the flame pattern is other than normal, consult the Troubleshooting Guide on Page 30 for corrective action.
7. Always preheat the Grill before starting to cook on the rotisserie.

MATCH LIGHTING THE ROTISSERIE BURNER:

1. Always open the Hood completely, before attempting to light the Grill.
2. Always confirm that all of the burner control knobs are in the OFF position before opening the gas supply.
3. Turn on the Propane Tank Valve at the tank (1 to 2 turns) or turn on the main natural gas supply valve.
4. Insert a lit match using the holder provided or a butane lighter into the match lighting hole located on the left hand side of the base. (Fig. 11)
5. Turn the Rotisserie Control Knob to the HIGH position by pushing down on the knob and turning it counterclockwise.

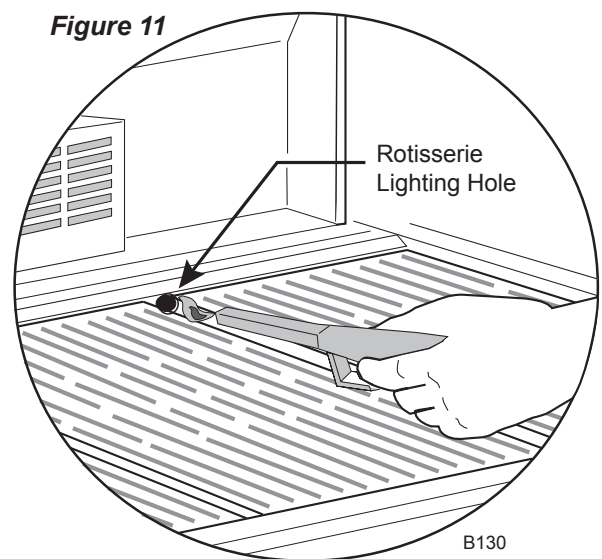

Rotisserie Setup (if equipped)

NOTICE

The rotisserie assembly includes a counterweight for large or irregular foods; using the counterweight reduces strain on the motor which is rated to turn a maximum of 12 lbs.

1. Attach the Rotisserie Motor Bracket to the left side of the base by aligning the holes and securing the pieces together using the two (2) bolts and two (2) lock nuts provided. (Fig. 12a)
 2. Remove the warming rack. Lay a flat noncombustible pan directly on the cooking grates to catch drippings. Large food items may require that you remove the middle cooking grate(s), and place the pan on the sear plates. Never use the main burners while using the rotisserie burner.
 3. Insert the ends of the Rotisserie Support into the slots of the right cooking grate, so the edge of the support is approximately 1" from the right casting, and the top groove is in line with the rotisserie spit hole in the left casting. (Fig. 12b)
 4. Engage the Motor Bracket to the left side of the base as per Rotisserie instructions.
 5. Engage the Rotisserie Motor in the Motor Bracket. (Fig. 12b)
 6. Assemble the spit and meat forks. Adjust the retainer bushing to keep the spit in place. (Fig. 12b)
 7. Tighten the thumbscrews with small pliers.
 8. Insert the Spit Rod into the Rotisserie Motor. (Fig. 12c)
- Never attempt to use the rotisserie burner for any purpose other than rotisserie cooking.

The rotisserie assembly includes a counterweight for large or irregular foods; using the counterweight reduces the strain on the motor. To keep unbalanced foods turning smoothly, assemble the counterweight outside of either rotisserie fork. (Fig. 12b) Adjust the weight to the opposite side of the heavy side of the food as needed. (Fig. 12d)

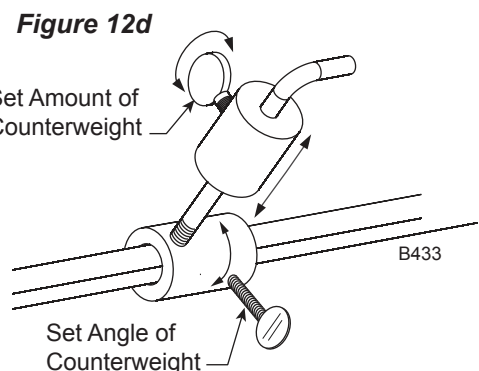
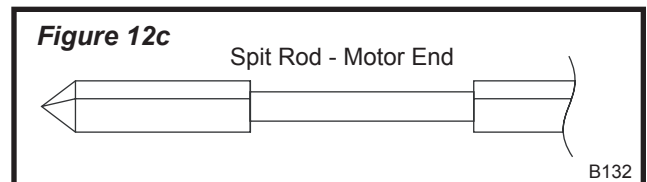
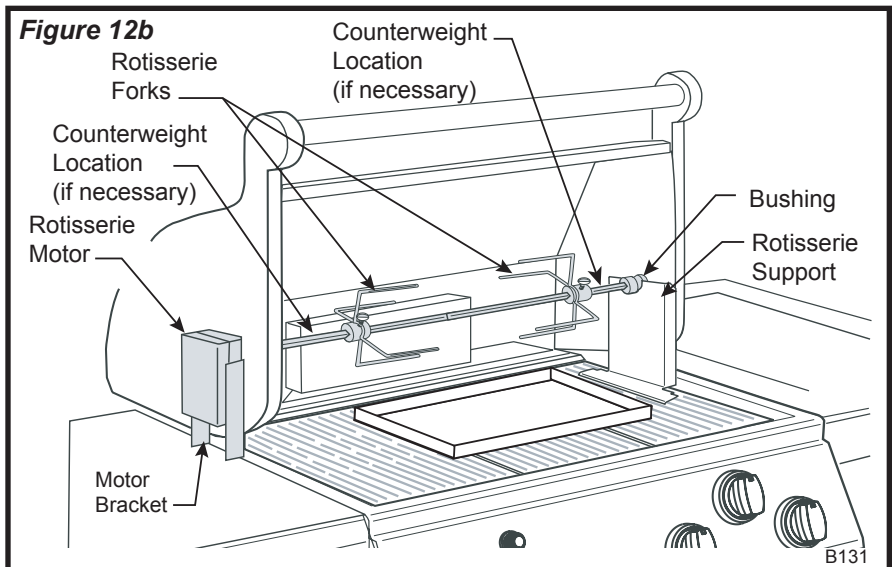
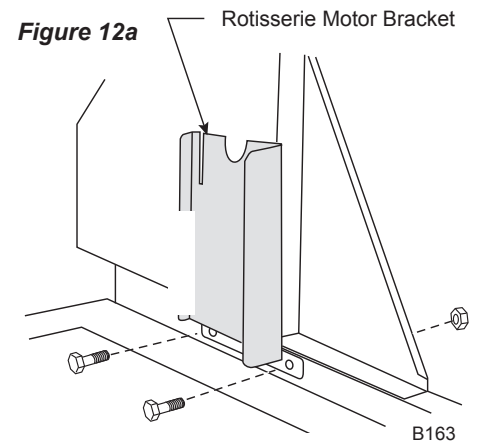

Rotisserie Setup (continued)

WARNING

- Never use the main burners while using the Rotisserie burner, as that could result in igniting the drippings, or overheating your Grill.
- Never use the Rotisserie Motor in the rain, and never use it if it has become wet.
- Always use a grounded three-prong outlet and a three-prong extension cord to energize the Rotisserie Motor. Never alter or remove the grounding prong on the Rotisserie Power Cord, as an electric shock hazard would then result.
- Keep any electrical supply cord and the fuel supply hose away from any heated surface.
- Electrical Grounding Instructions: This outdoor cooking gas appliance is equipped with a three-prong (grounding) plug for your protection against shock hazard and should be plugged directly into a properly grounded three-prong receptacle. Do not cut or remove the grounding prong from this plug.

Lighting the Side/Sear Burner (if applicable)

WARNING

NOTE: Burner assembly instructions are included in the box with the Burner Kit.

Never stand directly over the Grill when lighting the side/sear burner, to avoid exposure to possible flare-ups.

CAUTION: The Side/Sear Burner should only be operated with the protective lid/cover in the Up/Open position. Do not attempt to light the burner with the cover closed.

Side Burner Lighting Instructions

1. Ensure the main Propane Tank Valve or the main Natural Gas supply valve are in the on position. Turn the side burner control knob to HIGH. (Fig. 13a)
2. Push and hold the igniter button, you will hear a series of clicks as the igniter module generates an ignition spark to the burners. The burner should light within five (5) seconds. (Refer to Page 13)
3. Check the flame pattern. Soft blue flames are normal; hard blue flames or wavy yellow flames are not. Adjust the flame pattern with the air shutter below the control knob. (Fig. 18, as necessary) If the yellow flames persist, refer to the Troubleshooting Guide on Page 30.

Sear Burner Lighting Instructions

1. Ensure the main propane tank valve or main natural gas supply valve is in the On position.
2. Push in and turn the sear burner control knob counterclockwise to HIGH. Hold the knob pushed-in. You will hear a series of clicks as the igniter module generates repeated ignition sparks to the burner. The burner should light within five (5) seconds. After burner lights, release control knob.

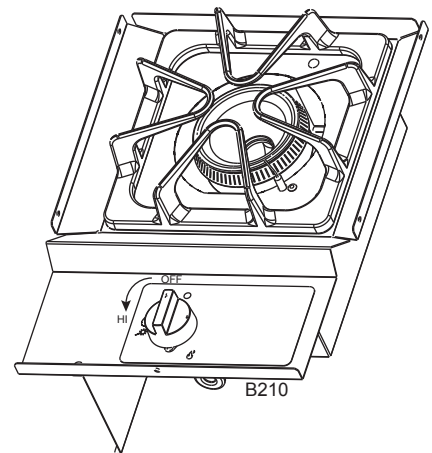

Figure 13a - Side Burner

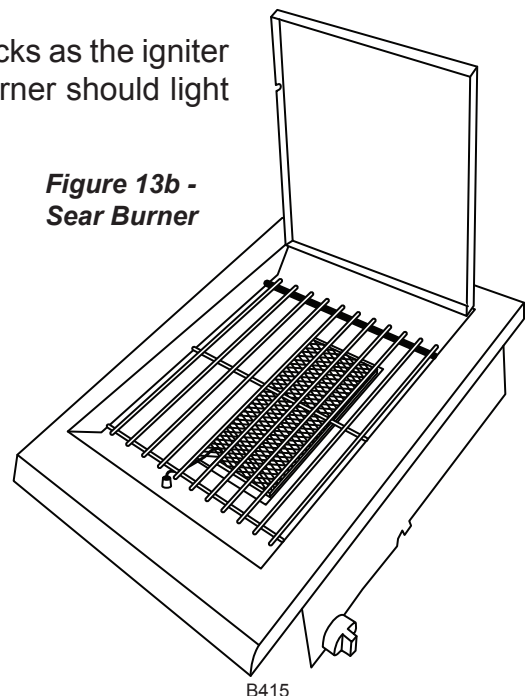

Figure 13b - Sear Burner

3. Check the flame pattern. After approximately 1 to 2 minutes, the entire burner should be glowing orange/red. Tall blue or yellow flames indicate the burner has insufficient combustion air. Check that the air shutter is fully open and ensure the venturi tube in front of the gas orifice is clear of blockage or debris (e.g. spider webs).

SHUTTING THE BURNER OFF

Turn the control knob counterclockwise to the HIGH position, then depress it and turn it to OFF.

NOTICE

NEVER apply force to the control knob without depressing it, as that can damage the valve.

Methods of Cooking

With its combination of burners and accessories your gas grill can provide for virtually every conceivable style of cooking.

- The powerful **Main burners** deliver the middle and high range of temperatures desired for traditional barbecuing. This includes searing and finishing steaks, hamburgers, pork chops and the like, or grilling chicken parts, sausages, or kebabs with more moderate heat. (Fig. 14a)

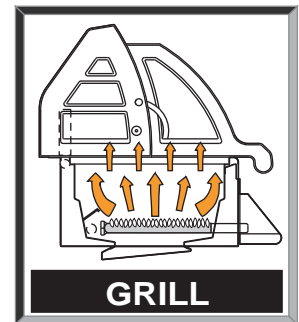

Figure 14a

- The **Rotisserie burner**, if equipped, delivers the succulent self-basted flavors of chickens, ducks and hams or pork, beef and lamb roasts that only rotisserie cooking can achieve. Also, the radiant infrared unit ensures that you will be enjoying the results much sooner. (Fig. 14b)



Figure 14b

- The **Side burner**, if equipped, boils, sautés, stir fries or warms all with equal aplomb. Plus its high power is more than adequate for deep frying seafood, vegetables and meats or hard boiling soups, lobsters or corn on the cob. (Fig. 14c)



Figure 14c

Using the Sear Burner

- The sear burner should be lit and glowing red before any food is placed on the searing grate.
- When cooking very lean meats such as chicken breasts or lean pork, the searing grate can be oiled before pre-heating to reduce sticking.
- The ceramic sear burner heats with infra-red radiant energy. This heat is much hotter than a conventional burner. Sear steaks, hamburgers or chicken pieces approximately 2 minutes per side. Adjust times according to the thickness of the food and your taste.

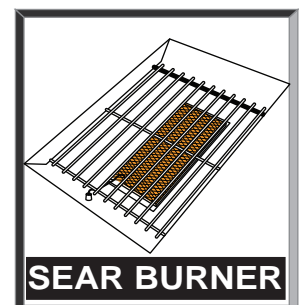

Figure 14d

CAUTION: Food left unattended over sear burner will burn quickly.

- Searing both sides of a steak gives you a rare steak. For medium to well-done steaks, and for other meats, after searing, move food to the main burners for complete cooking. Refer to instructions provided with your grill for cooking tips.

One of the keys to extending your range of grilling capabilities is a fundamental understanding of the two common methods of cooking, **Direct** and **Indirect** cooking.

In the **Direct cooking method**, food is placed directly above the heat source. This method is used in searing for example where you require high and immediate heat to quickly brown the outside layer of meats thereby sealing in their juices to enhance flavor. On the grill this is accomplished using one or more of your main burners and placing the food on the porcelain cooking grids directly over the burners. This may be done with the grill hood either open or closed.

In the **Indirect cooking method**, food is placed on the grill offset from the heat source. With the grill lid closed reflected heat surrounds the food cooking it more evenly and gently. This approximates the action of a convection oven where heat is circulated by the use of a fan to achieve a similar result. This method is perfect for cooking roasts of any kind but is also useful whenever you want to slow cook or bake a wide variety of foods. Indirect cooking on your grill is accomplished using one of the main burners and placing the food on the porcelain cooking grid above the opposite burner, or on the warming rack burner. The grill hood should always be closed when employing the indirect cooking method

PREPARING FOOD FOR THE GRILL:



Always observe safe food-handling and safe food-preparation practices when using this Grill, to prevent food-borne illnesses :

- Always cook foods adequately. Undercooked foods can retain bacteria, especially if thawed or exposed to warm conditions prior to cooking.
- Always use a meat thermometer to confirm that foods have been fully cooked.
- Always use separate plates and utensils for the handling of raw food. Never place raw food and cooked food on the same plate, and never place cooked food on a plate that was used for handling raw food. Always carefully wash all plates and utensils used to handle raw food before using them to handle cooked food.
- Always wash all vegetables, seafood and poultry before cooking.
- Always leave uncooked foods in the refrigerator until you are ready to start cooking.
- Always marinate meat in the refrigerator. Always dispose of the excess marinade, and never reuse it.
- Always preheat your Grill for 5 to 10 minutes before cooking, and always remove all grease and food residue before using the cooking grids.

Grilling Tips:

A few helpful hints will ensure that your grilling results are perfect every time.

- Apply a light coating of cooking oil to your cooking grids before grilling, to prevent foods from sticking.
- Cook similar portion sizes together, so they all cook evenly.
- Use tongs to turn foods on the Grill.
- Never pierce foods while they are cooking on the Grill, as this will dry them out.
- On foods such as pork chops and steak, slit the fat strip to prevent the meat from curling during cooking.
- Turn foods infrequently. Some chefs say that a good steak should never be turned more than once.
- Apply sugar-based sauces such as commercial barbecue sauces only during the latter stages of cooking, to prevent charring.
- Soak the string you use to tie up roasts and poultry on the Rotisserie spit to protect it from burning. Also, soak the wooden skewers that you intend to use for kebabs for several minutes before using them for cooking.
- Use a disposable aluminum tray filled with water, fruit juice, wine or a marinade to add extra flavor and moisture to slow-cooked foods like roasts, whole chickens, turkeys or ducks. Place the tray on top of the sear plates below the Grill surface and immediately under the foods being cooked. This will buffer the heat from below, thereby slowing the cooking process and protecting the bottom of the food from overcooking. Check the tray periodically during cooking and keep it filled with liquid.

WARNING

Never let the disposable aluminum tray boil dry, as any fat or grease that may have collected in the tray could then start a grease fire.

Always trim excess fat from your foods to reduce the occurrence of flare-ups during cooking.

Cooking Time Chart

Type of Food	Weight/ Thickness	Cooking Temperature	Cooking Time
Beef			
Burgers	1 inch	400–450° F.	Rare: 4–7 min. Medium: 7–10 min. Well Done: 10–12 min.
Roasts Blade, Sirloin Tip	--	350°	Rare: 18–20 min./lb. Medium: 20–25 min./lb. Well Done: 25–30 min./lb.
Steaks Porterhouse, Rib, Ribeye, Sirloin, T-Bone Filet Mignon	1 inch 2 inches	Maximum (To sear) 400–450° F. (To finish) Maximum (To sear) 400–450° F. (To finish)	Rare: 4–7 min. Medium: 7–10 min. Well Done: 10–12 min. Rare: 15–17 min. Medium: 17–19 min. Well Done: 19–22 min.
Poultry			
Chicken, Parts Chicken, Whole Chicken Breasts, Boneless Cornish Hens Duck Turkey	3–4 lb. 1–2 lb. 1–1½ lb. 4–5 lb. 13–25 lb.	325–350° F. 325–350° F. 325–350° F. 325–350° F. 325–350° F. 325–350° F.	30–45 min. 20 min./lb. 12–15 min. 45–60 min. 18–20 min./lb. 20 min./lb.
Fish & Seafood			
Fish Filletts Steaks Whole Fish	1–1½ inch 1–2 lb. 2–4 lb.	400–450° F. 325–350° F. 325–350° F.	10–15 min. 20–30 min. 30–50 min.
Seafood Lobster Shrimp	1½–2 lb. Large	400–450° F. 325–350° F.	15 min. 5–6 min.

Cooking Time Chart

Type of Food	Weight/ Thickness	Cooking Temperature	Cooking Time
Pork			
Chops	1 inch	400–450° F.	25–30 min.
Ham			
Steak	1 inch	400–450° F.	12–15 min.
Whole ham	12–14 lb. Bone in 4–5 lb. Boneless	325–350° F. 325–350° F.	Medium: 20–25 min./lb. Well Done: 25–30 min./lb. 50–60 min.
Ribs			
Back, Side	5–6 lb.	325–350° F.	Medium: 25–27 min./lb. Well Done: 27–30 min./lb.
Roasts			
Butt, Loin, Shoulder	3–5 lb.	325–350° F.	1–1½ hrs.
Tenderloin		375–400° F.	Medium: 30–35 min./lb. Well Done: 35–40 min./lb.
Sausage	—	325–350° F.	12–20 min.
Lamb			
Chops			
Loin, Rib, Shoulder	1 inch	400–450° F.	Rare: 7–9 min Medium: 10–13 min. Well Done: 14–17 min.
Roast			
Crown Roast	2–4 lb.	325–350° F.	40–45 min./lb.
Leg	5–9 lb.	325–350° F.	30–35 min./lb.

Cooking Time Chart

Type of Food	Cooking Temperature	Cooking Time	Comments
Vegetables			
Asparagus	325–350° F.	6–8 min.	Cut off ends of stems. Lay across the grills.
Beans	325–350° F.	30–35 min.	Wrap in foil with butter or margarine. Turn over once.
Carrots	325–350° F.	20–30 min.	Cook directly on the grill.
Corn on the Cob	325–350° F.	25–35 min.	Soak in cold water for 15 minutes. Cook with husk on.
Eggplant	325–350° F.	6–8 min./side	Cut into slices and coat with oil.
Mushrooms	325–350° F.	6–8 min.	Cook directly on the grill.
Onions	325–350° F.	40–45 min.	Wrap in foil. Turn over once during cooking.
Peppers	400–450° F.	15–20 min.	Remove charred skin before eating.
Potatoes	325–350° F.	50–60 min.	Wrap in foil. Turn over once.
Roasted Garlic	325–350° F.	30–40 min.	Cut off top of bud and lightly coat with Olive oil. Wrap in foil.
Tomatoes	325–350° F.	5–7 min.	Cut in half and coat in Olive oil.
Zucchini	325–350° F.	6–8 min./side	Cut into slices and coat with oil.

Care & Cleaning

WARNING

Always perform the following periodic inspections and preventive maintenance procedures to prevent flashback fires from occurring and to assure that your Grill will operate properly:

1. Always allow sufficient time for the Grill to cool to a safe temperature before handling or cleaning any of its components.
2. Always inspect all of the burners frequently, and clean them as often as is necessary.
3. Always inspect the air shutter screen periodically to confirm that it is clear of food residue, spider webs or other insect debris. A clogged venturi tube can cause a fire to occur beneath the Grill, due to a flashback of gas. (Fig. 15)
4. Loosen the burner attachment screws (from inside) to allow the burners to be pulled away from the valves far enough for a venturi brush or suitable cleaning device to be inserted into the burner venturi to clean away debris. (Fig. 15) Be careful not to damage the electrode ceramics.
5. Use a wire brush or toothpick to clean the ports all around the sides of the burner. (Fig. 16) It is normal for some surface rust to appear on the burner. Severe rusting can enlarge the gas ports, however, which could cause changes in the Grill's performance.
6. Reinstall the burners properly over the valves. (Fig. 20)

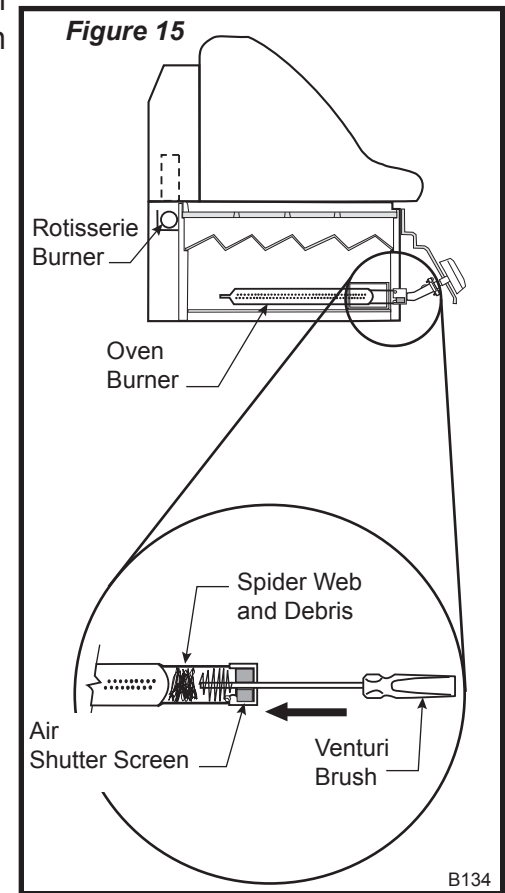
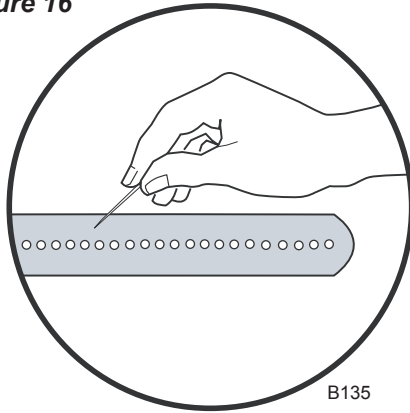

Figure 16



! WARNING

An impairment of flow through the venturi tube could cause a fire to occur beneath the Grill, due to a flash-back of gas.

Always keep all ports on the sides of the burner open (Fig. 16) by periodically cleaning them with a wire brush or toothpick.

- **Rotisserie Burner** (if applicable)

Inspect the Rotisserie burner monthly, if it is used frequently. Remove the rear panel (seven screws) to access the burner. Confirm that the burner ports and air shutter screen are clear of food residue, cobwebs or other insect debris. (Figs. 15 & 16)

- **Side/Sear Burner** (if applicable)

Inspect the air shutter screen periodically and confirm that it is clear of food residue, cobwebs or other insect debris. The Burner ignition electrode delivers a spark to ignite the gas at the burner. Always keep it clear of any buildup of foreign material, as that can act as an insulator and prevent the burner from lighting.

Figure 17

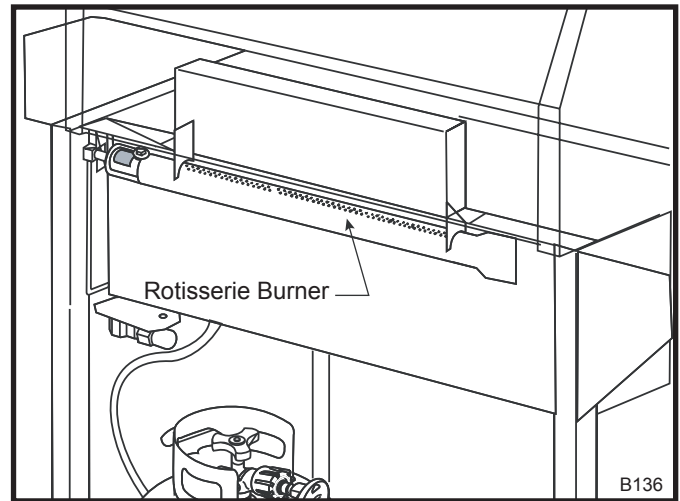

- Due to the high intensity heat of the infra-red sear burner, most drippings and food particles that fall onto the burner surface are immediately incinerated. However, some residue or debris may remain. To remove this residue after cooking, operate the sear burner on high for 5-10 minutes with the lid open.
- The ceramic of the burner is lightweight and brittle. Do not clean or strike the ceramic burner with a wire brush or any hard object. Do not use any cleansers to clean the burner.
- Dropping cold liquids onto a hot burner surface can cause it to crack. Do not throw or spray cold water onto the burner to control flare-ups.
- Always keep the protective lid Closed/Down when the burner is cooled and not in use.
- Do not attempt to light the sear burner if it is wet. Do not use the sear burner in open air while it is raining.

• Cooking Grids

The cooking grids have been porcelain enameled for durability and ease of cleaning. These Grills may be cleaned with any nonabrasive cleaning agent formulated for kitchen use, or a brass wire brush.

CAUTION

Always handle the grids with care, as porcelain enamel is very susceptible to chipping.

DRIP TRAY

The drip tray and grease cup, located under the burner pan in the bottom of the Grill body are provided to catch excess cooking fats and juices.

The drip tray is accessible from the rear of the Grill. It is necessary to lift up the pan slightly while pulling it out. (Fig. 18)

 Always confirm that the grill has cooled to a safe temperature before removing the drip tray and grease cup.

Check it for accumulations in the grease cup after each use of the Grill, and clean it as necessary.

Use lightly abrasive or nonabrasive products only for cleaning the drip tray.

Figure 18

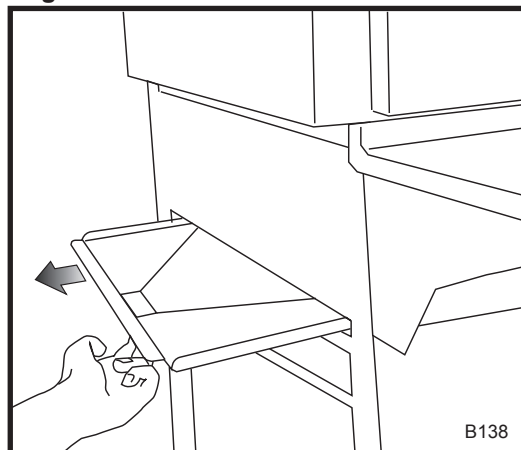

STAINLESS STEEL PANELS

Stainless steel is very durable and should last indefinitely with a minimum of care. Stainless steel is rust resistant, not rust proof. Minor surface rust may occur in the presence of salt (ocean) water or some cleaning agents that contain chlorine. Due to the nature of its brushed surface, minor scratches may appear with normal use and handling. These may be removed with the use of a fine to medium grade Scotch-Brite* (or similar) polishing pad. Apply gentle, even pressure while rubbing with the grain of the steel. Do not rub against the grain, as damage to the finish can result. Never use steel wool on the stainless steel.

Periodic cleaning with a nonabrasive cleaning compound, specifically formulated for stainless steel, will ordinarily remove any dirt, grease, cooking residue or discoloration that may develop.

CAUTION

Whenever possible, avoid the use of abrasive cleaning agents, scouring pads, or other abrasive materials to clean the stainless steel panels, to avoid scratching the surfaces. If abrasive materials must be used as a result of heavy accumulated smoke or grease build-up, always rub with the grain of the stainless steel, (never against the grain).

PORCELAIN ENAMEL CASTINGS

Periodic cleaning with a dry or slightly damp cloth or soft brush will keep porcelain enamel surfaces looking new. Use a kitchen appliance cleaner or a polish expressly formulated for use on porcelain enamel to clean the porcelain enamel castings. Treat it as you would a porcelain sink. Dishwasher safe.

CAUTION

Never use abrasive cleaning agents or abrasive materials to clean the porcelain enamel castings, as they will permanently scratch the porcelain enamel surfaces.

Maintenance

BURNER ADJUSTMENT

NOTICE

It may be necessary to adjust the burners periodically, to compensate for variables in gas characteristics. If you notice the burner flame pattern is irregular (Refer to Page 14, Figures 9a, 9b & 9c), it may be necessary to adjust the air shutter opening at the front of the venturi tubes.

- The shutters are accessible under the control panel at the front of the Grill. (Fig. 19)
- Use a screwdriver to loosen the locking screws. Open the shutter just enough to achieve the desired soft, blue flames. Make adjustments in small increments and allow the burner to come up to operating temperature (10 min.) before making further adjustments.

WARNING

Always allow sufficient time for the Grill to cool to a safe temperature before handling or cleaning any of its components.

Figure 19

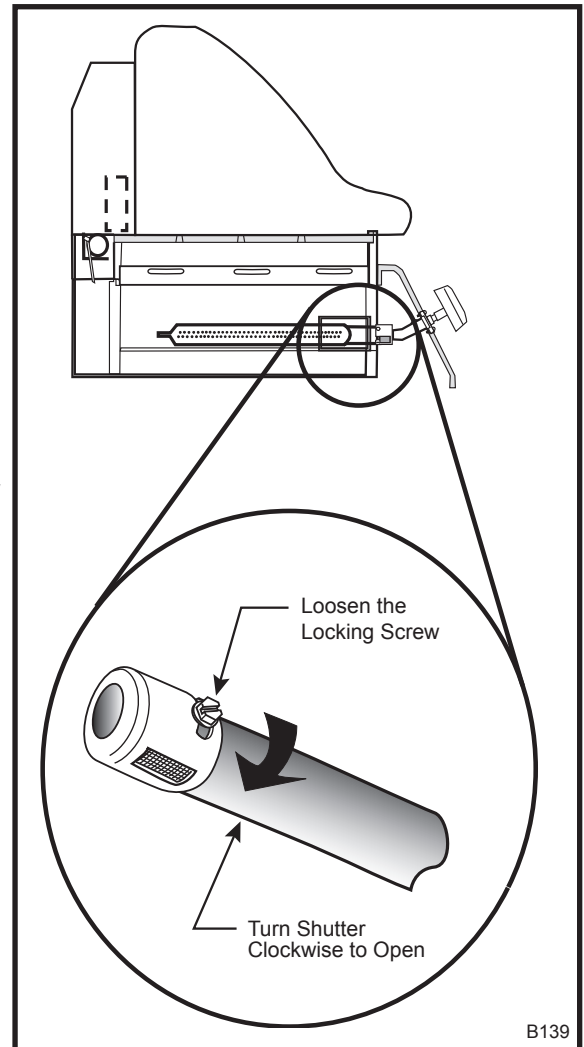

If burners are removed for cleaning or adjustment, always confirm that they have been reinstalled correctly over the valve outlets. (Fig. 20) The valves should extend into the burner venturis 1/4" minimum.

NOTICE

Similar adjustment can be made to Rotisserie and/or Side Burners, if so equipped.

Figure 20
Venturi Tube

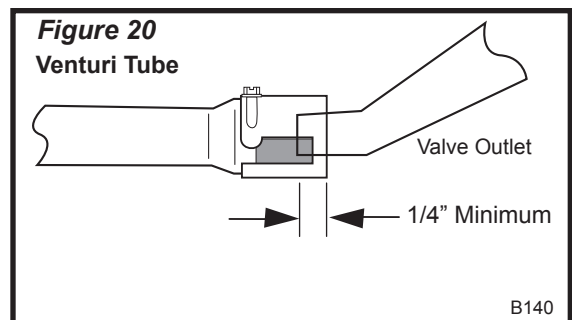

B140

PROBLEM	POTENTIAL CAUSE	ACTION REQUIRED
Burner will not light	<p>Gas supply turned off</p> <p>Out of propane</p> <p>Blockage in the gas system</p> <p>Misalignment of the gas valve to the venturi tubes of the burner.</p> <p>Improper attachment of the propane hose and regulator</p>	<p>Turn on fuel supply and retry.</p> <p>Confirm the flow of gas by smell or by listening for the hiss of gas being emitted. Allow gas to clear before attempting to relight.</p> <p>Weigh your propane cylinder. A standard 20 lb. cylinder will weigh about 19 lbs. when it is empty and 39 lbs. when it is 80% full.</p> <p>⚠ WARNING Never take a propane cylinder indoors for any purpose.</p> <p>Confirm the venturi tubes are not blocked by insects or other debris. Use a special venturi brush to clean. (Fig. 15)</p> <p>Use a wire brush or toothpick to carefully probe the orifice in the gas valve. Never enlarge the orifice.</p> <p>Look under the front control panel and re-insert the gas injector into the venturi tube, if required. (Fig. 19)</p> <p>Tighten the regulator's plastic collar onto the cylinder valve. Hand-tighten only. (Fig. 4)</p>
Unit won't heat up (LP)	<p>Control knob left open at startup, or turning gas on too quickly or cold climate or windy conditions</p>	<p>For safety, the regulator coupling on your barbecue is equipped with a flow control mechanism. This device limits gas flow in the event of a sudden change in the demand for gas. This may be engaged inadvertently, if a burner control knob should be left ON when you open the propane cylinder valve. Rapidly opening the valve can also engage flow control. To resolve the problem, close your cylinder valve. Confirm that all burner control knobs are in the OFF position. Open the cylinder valve slowly (about 1 to 2 turns) and wait 5 seconds. Finally, turn a single burner ON and try relighting it.</p>
Unit won't stay lit	<p>Wind</p> <p>Running out of fuel</p>	<p>Always shelter your Grill from strong winds.</p> <p>Confirm the flow of gas by smell, or by listening for the hiss of gas being emitted.</p> <p>Weigh your propane cylinder. A standard 20 lb. cylinder will weigh about 19 lb. when it is empty and 39 lb. when it is 80% full.</p> <p>⚠ WARNING Never take a propane cylinder indoors for any purpose.</p>

PROBLEM	POTENTIAL CAUSE	ACTION REQUIRED
Uneven burn pattern or Flashback fire	Blockage in the burner or gas system Corroded burner	Confirm that the venturi tubes are not blocked by insects or other debris. Use a special venturi brush to clean. (Fig. 15) Use a wire brush or toothpick to probe the orifice in the gas valve. Never enlarge the orifice. Use a small nail or toothpick to clean the burner ports. (Fig. 16) Corrosion of a gas burner can cause the solid material between the gas ports to deteriorate, resulting in uneven burning. See your retailer for the appropriate replacement burner.
Excessive yellow flame	Improper air shutter opening	Your Grill should burn with a predominantly blue flame. If the flame is mostly yellow, check the venturi tubes for obstruction and clean as shown on Page 18. If yellow flames still persist, adjust the opening on the air shutter of the venturi tube located under the front console of the Grill. (Fig. 19)
Flare-up	Excessively fatty foods Grease buildup	Trim all excess fat from meat before cooking. Confirm the sear plate and drip tray are clean and properly installed. Remove excess grease from the burn chamber. Turn down the heat.
Igniter does not spark	Electrode fouled Electrode improperly gapped Electrode cracked Lead wire is disconnected Lead wire is cracked Battery dead or installed wrong	Wipe the electrode with a soft, clean cloth. The electrode should be located 1/8" to 3/16" from the burner, and positioned to spark to the edge of a gas port. If the gap is incorrect, or the unit is not properly sparking, gently bend the electrode tip into position. Use caution so the ceramic insulator does not crack. If the ceramic insulator on the electrode is cracked, it may short out. Replace the electrode. Confirm that the lead from the igniter module to the electrode is well seated on the termination of the module. A crack in the lead wire may result in shorting. Replace the wire. The battery in the Igniter Button may be dead or installed incorrectly. Correct position is positive end down.

◆ **Limited Lifetime Warranty**

- Rust through on all Exterior Stainless Steel Components
- All Cast Iron End Caps
- Stainless Steel Cabinetry & Lid

◆ **10 Year Warranty**

- Porcelain Coated Firebox and Rear Lid Assembly (Burn through or Rust through)
- All Stainless Steel Burners except Side Burner
- Cast Iron Cooking Grates

◆ **5 Year Warranty**

- Porcelain Coated or Stainless Steel Heat Plates (Burn through or Rust through)
- Side Burner
- All Remaining Parts
- Porcelain Coated Warming Rack (Burn through or Rust through)

◆ **2 Year Warranty**

- Grill Lights & Rotisserie - electrical and mechanical parts (if applicable)
 - Rotisserie Burner
 - All Painted Parts
- Limited Lifetime Warranty is limited to 25 years and is applicable to original owner.
 - The warranty is nontransferable.
 - It does not cover failures due to misuse or improper installation or maintenance.
 - The warranty is for replacement or repair of defective parts only. Vermont Castings Group will not be responsible for incidental or consequential damages or any labor costs.
 - This limited warranty does not cover damage due to chipping and scratching of porcelain or painted surfaces nor does it cover corrosion or discoloring due to misuse, lack of maintenance, hostile environments, accident, alterations, abuse or neglect.
 - This limited warranty does not cover any scratches, dents, corrosion or discoloring by heat, abrasive and chemical cleaners nor chipping on porcelain enamel parts, nor any components used in the installation of the gas grill.
 - Please retain your bill of sale for future warranty claims or inquiries. A receipt and serial number is required for warranty service.

Vermont Castings Group

149 Cleveland Drive • Paris, Kentucky 40361
www.vermontcastingsgroup.com