

NEOREST 550

MS980CG



NEOREST

Safety instructions	2
Operational Instructions ..	7
Performance Features	8
Parts and Features	10
Before Using	13
• Adjusting time.....	13



Introduction

Standard use	16
Amenities	18
• Temperature Adjustment....	18
• Deodorizer.....	20
• Soft Light.....	21
• Seat/Lid open/close.....	23
• Changing the lid auto close waiting time.....	24
• Flushing.....	26
• Changing the auto flush waiting time.....	27
Energy Saving Feature....	30
• Using the time saver.....	31
• Using the auto saver.....	33



Operation

Maintenance.....	35
• Before cleaning.....	35
• Regular cleaning.....	37
• Thorough cleaning.....	38
• Cleaning the top unit, seat and lid...	38
• Routine Cleaning.....	40
• Checking/cleaning power plug....	40
• Cleaning deodorizer filter.....	40
• Cleaning the wand.....	41
• Cleaning the toilet bowl.....	41
• Cleaning the water filters.....	43



Maintenance

Power/water failure	46
Preventing damage caused by freezing conditions or disuse....	47
Troubleshooting.....	50
Specifications.....	55
Replacing deodorizer cartridge.....	56
• Limited Warranty.....	57



Troubleshooting

● Thank you for your recent purchase of the TOTO NEOREST. Please read the enclosed information to ensure the safe use of your product.

Safety Instructions

Follow these instructions strictly!

Please carefully read the safety instructions to ensure the safe use of the product. Follow the instructions strictly because they concern personal safety.

Symbols and Meanings



Warning

Improper use or installation of this product may result in death or serious injury.



Caution

Improper use or installation of this product may result in injury or property damage.

Symbols and Meanings



Prohibited.

This symbol is used to indicate no tampering with this product.



Mandatory

This symbol is used to indicate a required step in the use of this product.

Warning



Keep dry

Keep the top unit and the power plug away from water

- Fire or electric shock may occur.
- Injury or flood may occur if the toilet bowl is broken.



Keep dry

Do not install the product in a room where the humidity can exceeds 90% RH

- Fire or electric shock may occur.



Do not tamper

Never tamper, repair or modify the product

- Fire or electric shock may occur.



Keep wet hands away

Do not pull out the plug with wet hands

- Fire or electric shock may occur.



Do not!

If trouble occurs, stop using the NEOREST

- In the following cases, pull out power plug and close the water shutoff valve.

Trouble such as:

- Pipe or product leakage
- Crack or breakage
- Abnormal sound or smell
- Smoke from the product
- Abnormal heat
- Clogging

- Continuing to using the product when it is showing signs of trouble may cause fire, electric shock or flood.



Do not!

Be careful not to damage the power/seat cords

Do not pull, twist, bend, harm, modify, heat or place heavy material on the cords.

- Continuing to use the product when it is damaged may cause fire, electric shock or short circuit.

Warning



Do not!

Do not use a loose or faulty electrical outlet

- Fire or electric shock may occur.



Do not!

Do not use water other than tap water, portable water or well water (underground water)

- Skin irritation may result.



Do not!

Do not use the outlet beyond its intended capacity.

- If multiple plugs cause the outlet to be used beyond its capacity, overheating can cause fire.



Do not!

Only use specified power supply (AC 120V)

- Fire may occur.



Mandatory

Beware of warm scalding

- If you are going to sit on the seat for a long time, set the seat temperature to OFF.
- The seat temperature should be turned to OFF and the dryer temperature should be turned to LOW prior to use by the types of users listed to the right.

- Children or elderly people who have trouble adjusting the temperature settings
- Sick or disabled users who do not have freedom of movement
- Users that have consumed a great deal of alcohol or who are extremely tired and may fall asleep while using the toilet.



Mandatory

Clean the plug regularly and re-insert it firmly in the outlet

- Fire or electric shock may result. Pull out the plug and use soft dry cloth to clean it.



Mandatory

Hold the plug to pull it out of the outlet socket

- If you pull on the wire to get the plug out, it may cause injury, fire or electric shock.



Do this way

Unplug the product before carrying out maintenance

- Fire or electric shock may result
- Exception: when you use the wand cleaning or rinse cycle features



Grounding

Confirm that the grounding is installed (Type B)

- If trouble such as leakage occurs, electric shock may result. If necessary, get a qualified person to install the grounding.

Caution



No fire

Keep fire or flame such as cigarette and cigars away from the product

- Fire may result.





Caution



Do not insert a finger into or keep hands near the dryer outlet

Do not cover the dryer outlet with your hand or anything else

Do not!

- Scalding, electric shock or burning may result.



Do not compress the product, do not leave or load heavy material on the seat, lid or toilet bowl.

Do not!

- If a person falls down on the product, they could be injured or the product could be broken.
- If the toilet bowl is broken, a flood may result.



When cleaning plastic parts (such as the top unit), it is recommended to use kitchen detergent (thin and neutral), and to avoid using following materials (Toilet detergent, household detergent, benzene, thinner, cleanser and nylon scrubber)

Do not!

- Plastic parts may be damaged or broken.
- If the water supply pipe is broken, flood may result.



When the water shutoff valve is opened, don't remove the water supply filter or the drain valve.

Do not!

- Water may shoot out.

[See page 43 for maintaining water filter.](#)



Do not bend or twist the water supply hose

Do not!

- Water leakage may result.



Do not attempt to flush items other than toilet paper and bodily waste.

Do not!

- If the toilet bowl is blocked, the room will be flooded with dirty water.



If leakage occurs, close the water shutoff valve.

Mandatory



If the product will not be used for a long time, please detach the power plug.

Mandatory

- For safety reasons, please pull the plug out.
- When the NEOREST is used again, re-circulate water because stagnant water may cause skin irritation.

[See page 48 for water recirculation.](#)

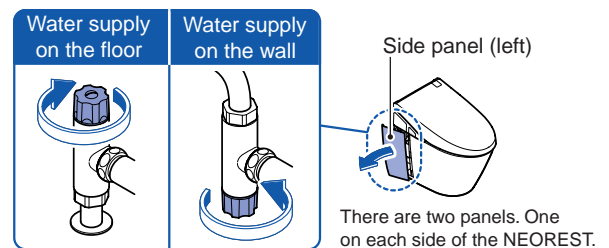

The water supply filter and drain valve should be firmly installed.

Mandatory

- Leakage may result.



Preventing freeze damage

Mandatory

- The water supply pipe or top unit may be broken by freezing water, leakage may result.
- Please maintain a temperature above freezing in the room where the product is installed.

[See page 47 for preventing damage due to freezing](#)



If the NEOREST becomes clogged, detach the power plug until it is unclogged.

Mandatory

- If the NEOREST is not unplugged, the auto flush feature may cause the clogged NEOREST bowl to overflow.
- Do not attempt to use a plunger on the NEOREST without first unplugging it.

**DANGER****To reduce the risk of electrocution:**

1. Do not use while bathing.
2. Do not place or store products where it can fall or be pulled into tub or sink.
3. Do not place in or drop into water or other liquid.
4. Do not reach for a product that has fallen into water. Unplug immediately.

**WARNING****To reduce the risk of burns, electrocution, fire or injury to persons:**

1. Close supervision is necessary when this product is used by, on, or near children or invalids.
2. Use this product only for its intended use as described in this manual. Do not use attachments not recommended by the manufacturer.
3. Never operate this product if it has a damaged cord or plug, if it is not working properly, if it has been dropped or damaged, or dropped in water. Return the product to a service center for examination and repair.
4. Keep cord away from heated surfaces.
5. Never block the air openings of the product or place it on a soft surface, such as a bed or couch, where the air openings may be blocked. Keep the air openings free of lint, hair, and the like.
6. Never use while sleepy or drowsy.
7. Never drop or insert any object into any opening or hose.
8. Do not use outdoors or operate where aerosol (spray) products are being used or where oxygen is being administered.
9. Connect this product to a properly grounded outlet only. See Grounding Instructions.
10. Reservoir should be filled with water only.

**Save these instructions.**

Grounding Instructions

This product should be grounded. In the event of an electrical short circuit, grounding reduces the risk of electric shock by providing an escape wire for the electrical current. This product is equipped with a cord having a grounding wire with a grounding plug. The plug must be plugged into an outlet that is properly installed and grounded.



DANGER - Improper use of the grounding plug can result in a risk of electric shock.

If repair or replacement of the cord or plug is necessary, do not connect the grounding wire to either flat blade terminal. The wire insulation having an outer surface that is green with or without yellow stripes is the grounding wire.

Check with a qualified electrician or serviceman if the grounding wire instructions are not completely understood, or if in doubt as to whether the product is properly grounded.

This product is factory equipped with a specific electric cord and plug to permit connection to a proper electric circuit. Make sure that the product is connected to an outlet having the same configuration as the plug. No adapter should be used with this product. Do not modify the plug provided - if it will not fit in the outlet, have the proper outlet installed by a qualified electrician. If the product must be reconnected for use on a different type of electric circuit, the reconnection should be made by qualified service personnel.

If it is necessary to use an extension cord, use only a three wire extension cord that has a three blade grounding plug, and a three-slot receptacle that will accept the plug on the product. Replace or repair a damaged cord.

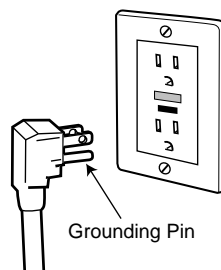

Operational Instructions

Please follow these instructions.

Avoid damage to the product	
Use soft damp cloth or toilet paper to clean the top unit, seat and lid	Do not lean against the lid
See page 35 for maintenance	

Avoid damage to the product	
Avoid spattering urine on the top unit or on the wand	If there is a thunderstorm, unplug the NEOREST

These may reduce performance	
Do not cover seat sensor A, seat sensor B, the remote control signal receiver or remote control signal emitter The NEOREST may not respond appropriately to commands.	Keep radio receivers away from the NEOREST. You may hear noise from your radio receiver.
Don't expose the product directly to sunlight Color change, irregular temperature, remote control malfunction and sensor malfunction may result.	After using an assisting seat or soft height seat for children, please remove it. Some functions might not be available.



Performance Features

Cleansing		Page
Wonder Wave Rear cleansing	The Wonder wave cycles between strong and soft sprays of water approximately 70 times per second for a very thorough rear wash. The Wonder Wave offers you an unprecedented experience. This feature uses a rotating water flow that can clean in a wide range.	16
Wonder Wave Soft rear cleansing		16
Wonder Wave Front cleansing		16
Position adjustment	Adjusts the wand in backward and forward.	16
Adjusting water pressure	Adjusts the water pressure for the cleansing features.	16
Oscillating cleansing	The nozzle moves back and forth for a wide-ranging and thorough cleansing.	16, 17
Pulsating cleansing	Uses alternating strong/soft water pressure to cleanse.	16, 17

Amenties		Page
Heated toilet seat	Warms the toilet seat.	–
Warm air drying	Dries wet portions with warm air.	16
Temperature adjustment	Adjusts the water, seat and dryer temperatures.	18, 19
Deodorizer	Removes the toilet bowl odors.	20
Remote control	Allows for easy operation when a person is seated on the NEOREST	12
Seat sensor	All functions are available when a person seated on the toilet bowl is detected.	17
Remoted controlled seat and lid	Open or close the seat and lid with the remote control.	23, 24
Auto open/close	Sensor A detects heat and automatically opens/closes the lid when a person approached the NEOREST.	23~26
Remote controlled flush	Flushes the toilet via remote control.	26
Automatic flush	Automatically flushes the NEOREST when a person finishes using it.	27~29
Clock	Displays the time on the remote control	13
Soft light	Turns on when the sensors detects a person near the NEOREST.	21, 22

Energy Saving Features		Page
Timer ON/OFF	Conserves energy by turning off the seat heater for either 3, 6 or 9 hours at the same time every day. (See page 28)	30 ~ 32
Auto ON/OFF	Records information about when the NEOREST is being used, determines when it is least likely to be used, and reduces the seat temperature to save energy during that time	30, 33, 34
ON /OFF Button	Turns the power to the NEOREST ON or OFF. When the NEOREST is OFF the seat heater is not running. This contributes energy savings.	15

Cleaning function		Page
Removable seat and lid	Seat and the lid can be removed for easy cleaning.	38, 39
Antibacterial	Seat, buttons and other frequently touched parts are treated with an antibacterial coating.	–
Self-cleaning	The wand washes itself before and after each use.	–
Wand cleaning	Wand can clean itself completely when it extends or retracts.	–
Clean-coat wand	The wand is treated with smudge resistant coating.	36
Wand cleaning button	Used to extend the wand for manual cleaning.	41
Rinse Cycle	Runs water through the toilet bowl for longer than a normal flush cycle to help during manual cleaning.	41, 42
Easy-to-clean Toilet bowl	With SanaGloss technology, it is difficult for the dirt to adhere to the toilet bowl making it is easy to clean.	–
Gasket	Prevents liquid and dirt from getting in between the top unit and the toilet bowl.	10
Antibacterial seat	The seat is made from an antibacterial resin, which makes for easy cleaning.	–

Parts and Features

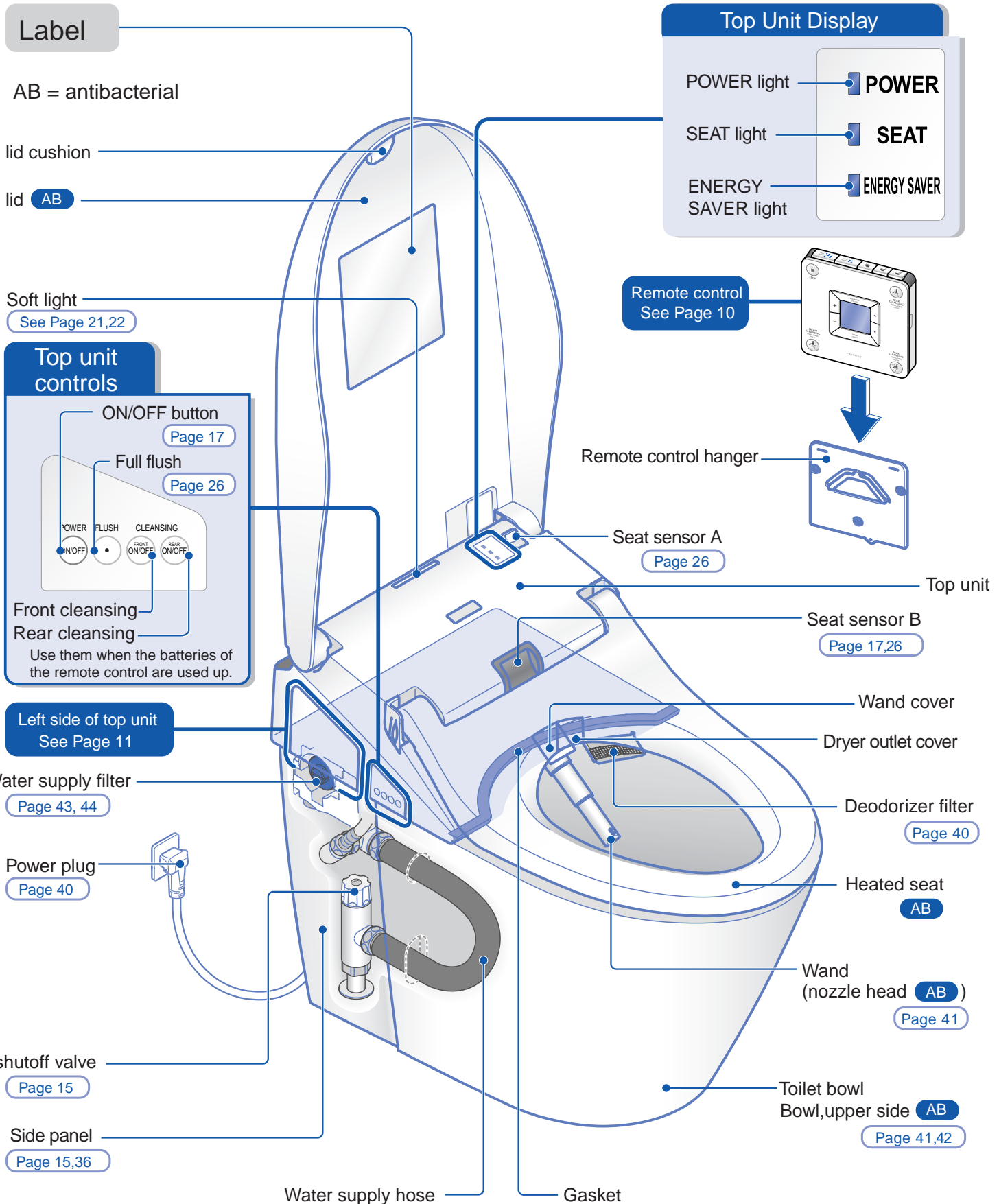

Top unit, top

Remote control
signal receiver

Soft light

Page 21,22

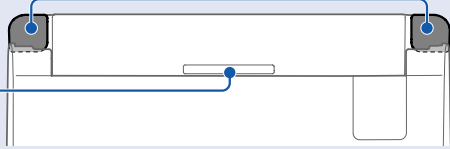

Top unit, right

Deodorizer
cartridge

Page 56

Deodorizer
venting hole

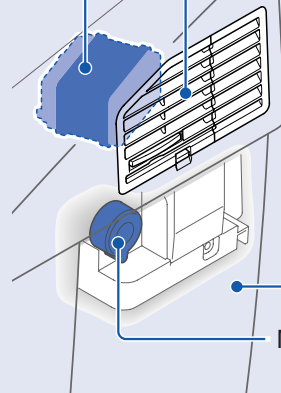

Side panel

Manual flush knob

Page 28,46

Top unit, left

Top unit water
shutoff valve

Drain valve
water filter

Page 43,44

Regulation lever

Page 49

Cover

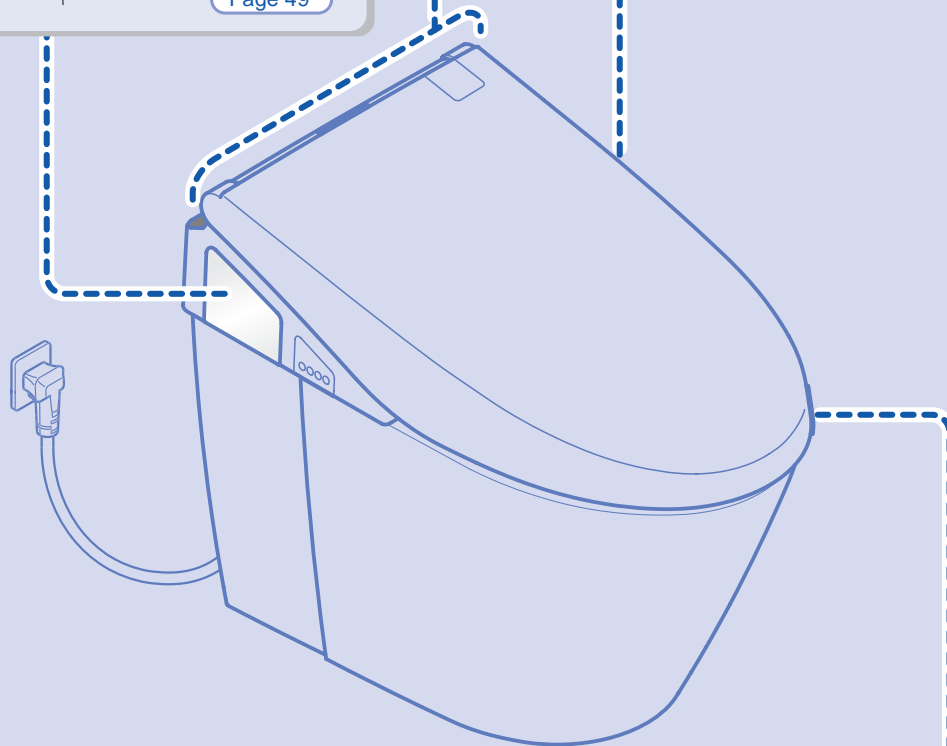
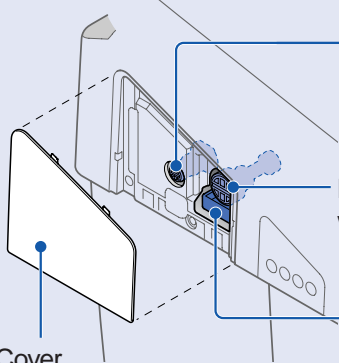

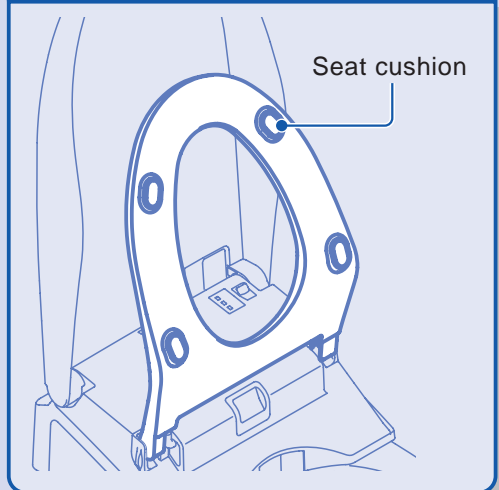

Seat interior

Seat cushion



Remote control buttons have an antibacterial coating.

- For people with poor-sight,   the symbols on these buttons can help.
- When a button is pushed, the remote control display light will turn on for 10 seconds.
- When a button is pushed, a discription will be shown on the display.
- When the NEOREST receives a signal from the remote control, it will give out a beep. [Page 19](#)
- When a button is pushed, the current setting will be shown on the remote control display.

When the cover is closed

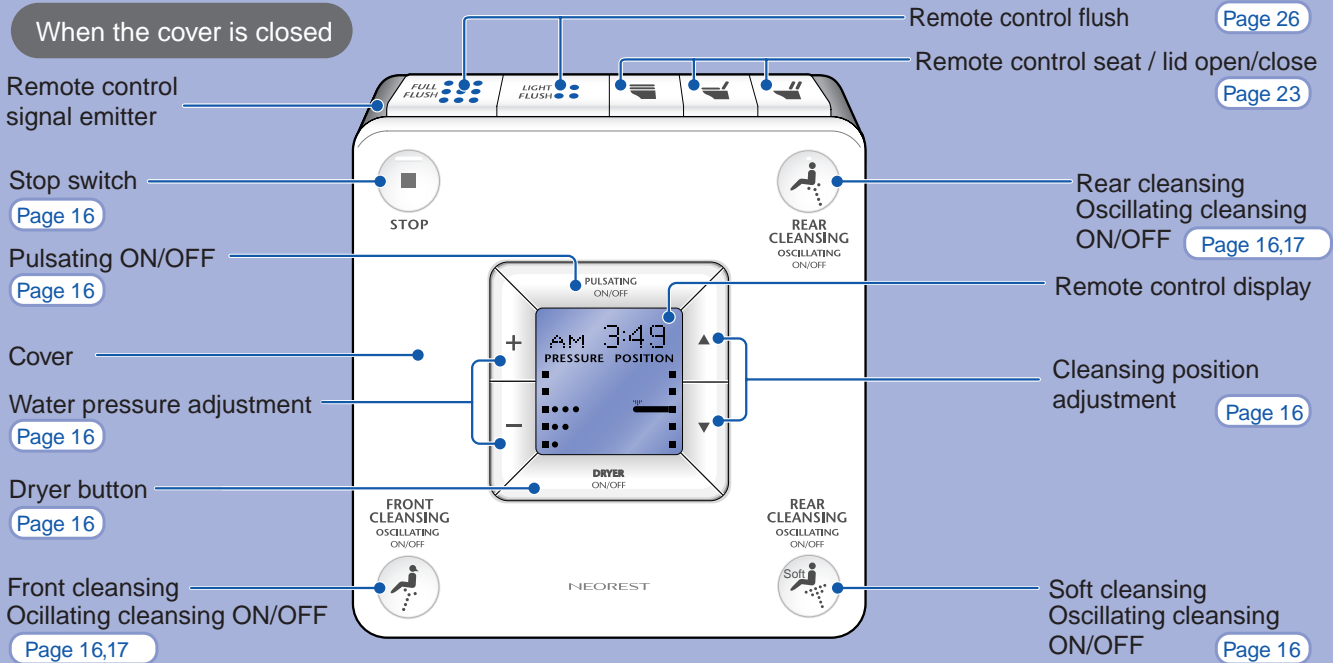

When the cover is open

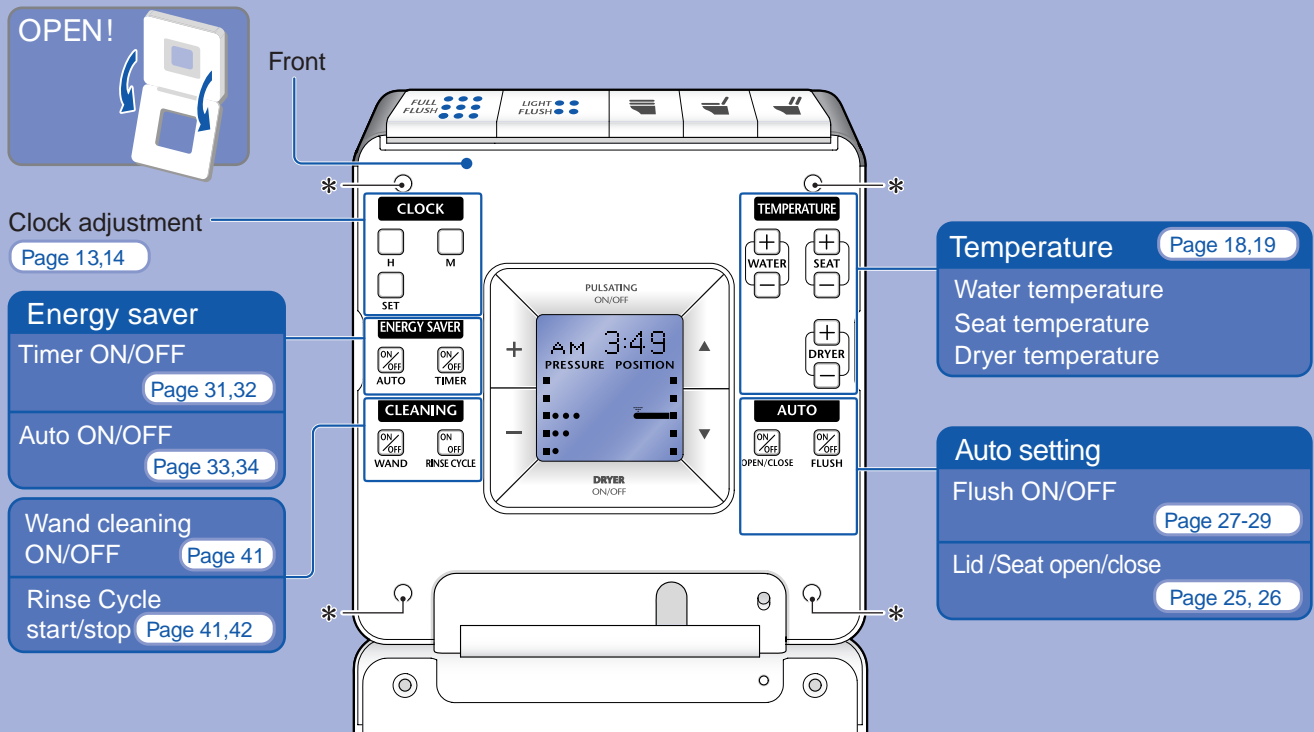

- When the batteries are low, the remote control displays . Please replace the batteries. [Page 13](#)
- When taking the remote control off of its hanger, hold the remote from its sides in order to avoid unintentionally pushing the buttons on the remote control cover.
- If a person needs handrail assistance in order to get up off the NEOREST, they should be careful not to unintentionally push the buttons on the remote control cover as they get up.
- *Do not use these 4 buttons.

Before Using

Before Using

1: Inserting batteries into the remote control

1 Remove the remote control cover from the hanger

- Grasp the sides of the remote with both hands and lift straight up.

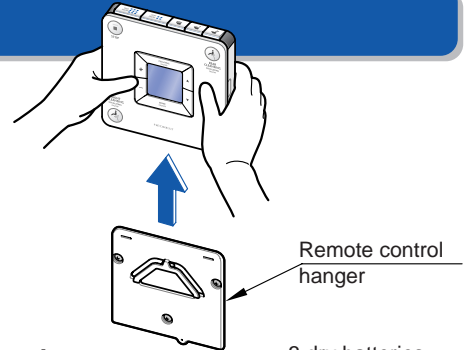

2 Open the battery cover on the remote control

3 Insert 3 batteries properly.

Tip

- When replacing batteries or performing maintenance, set the **POWER ON/OFF** button to OFF using the button on the top unit. Improper operation may lead to accidentally starting the rinse cycle or opening/closing the seat / lid.
- When the batteries are replaced, the auto energy saving timer is reset to the default OFF setting. The auto cleansing is reset to the default ON setting. If a different setting is performed, please set it again.

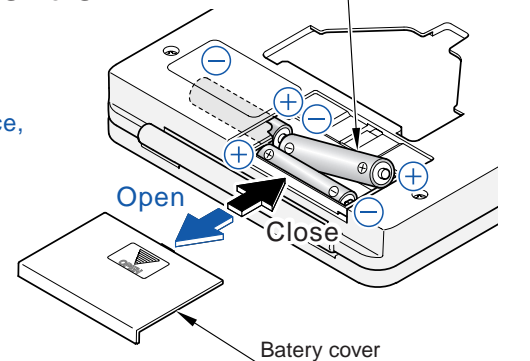

4 Close the battery cover

Confirm this! Remote control display

When you have properly inserted batteries, the remote control display will look like this.

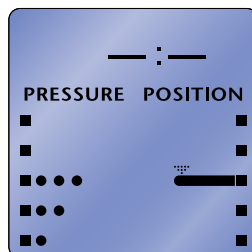

About batteries

Use alkaline batteries. Follow these instructions to prevent battery breakage or leakage.

- When replacing batteries, use new batteries.
- When the remote control is not used for a long period of time, please remove batteries.
- Do not use rechargeable batteries.

Before Using

2: Adjusting time

(In this example, the time is set to 10:15AM)

1 Open the remote control cover

Time setting buttons

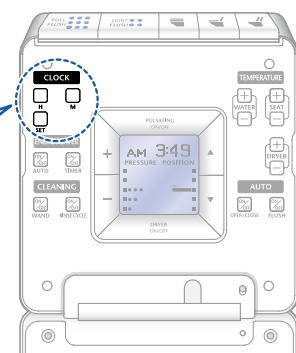
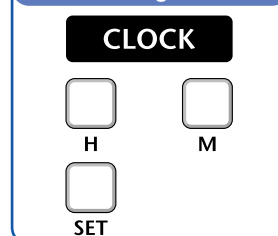

Open the cover

2

Push  on the remote control.

The time can now be changed.

- The time flashes on the remote control display.

Tip

- If the clock is flashing and none of the buttons on the remote are pushed for more than a minute, the display will return to normal. You can only set time while the display flashes. To get the display flashing again, press the set button again.

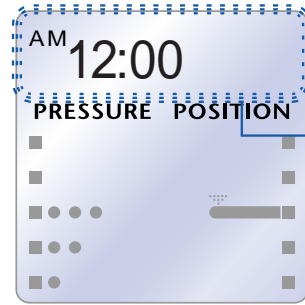

Confirm
Flashing

3

While the time is flashing, push  on the remote control to change the hour.

- Push  to set to 10 AM

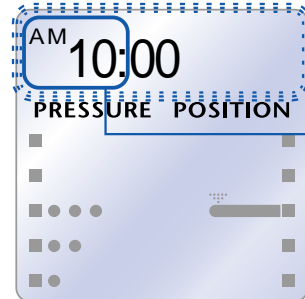

Confirm
AM10
is displayed

4

While the time is flashing, push  on the remote control to change the minute.

- Push  to set to 15



Confirm
15
is displayed

5

Push .

The new time is set.

- The new time is shown on the remote control display.

Tip

- When the remote control receives a signal from the top unit, it will give out a beep.

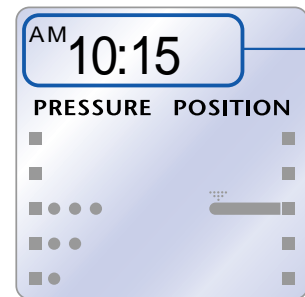

The new time
is displayed

Before Using

3: Insert the power plug into the outlet

Tip

- If the lid is not either fully up or full down when the NEOREST is plugged in, it will stop at that same inbetween position the next three times it is opened or closed. Please confirm there is nothing holding the lid in an inbetween position before inserting the plug. Then push  on the remote control.
- When the plug is inserted, the soft light will flash for somewhere between 10 seconds to a minute. During this period, the seat sensor A is initializing. The auto lid open/close feature will not function until the sensor is done initializing, but the seat and lid can still be operated using the remote control.

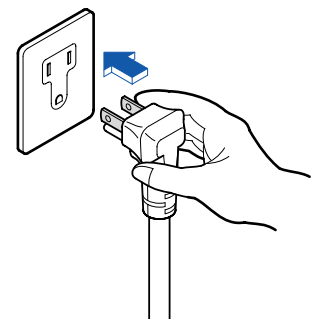

4: Opening the water shutoff valve

- 1 Hold the rear part of the side panel and pull in the direction shown below.

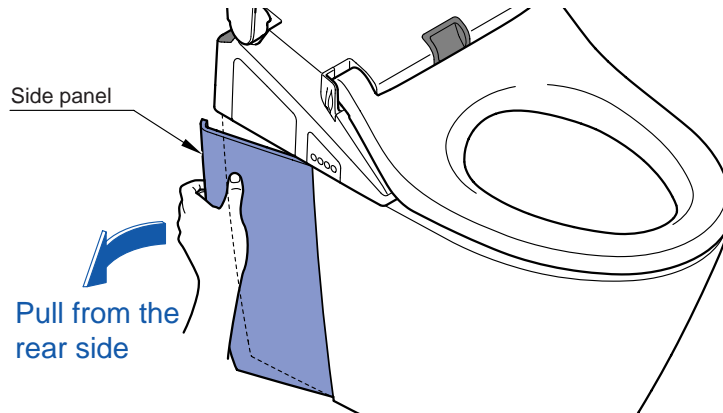

- 2 Open the water shutoff valve completely in the direction shown below.

Water supply on the floor

Water supply on the wall

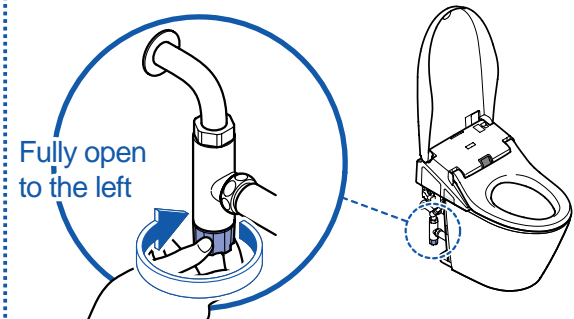
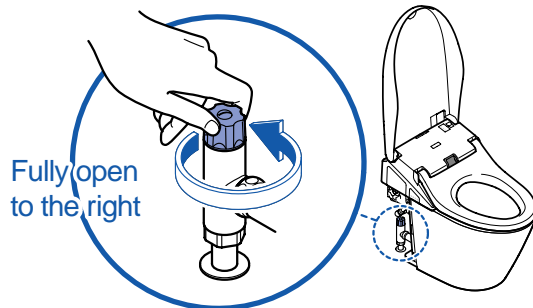

- 3 When installing the side panel, align it with the lines on the china.

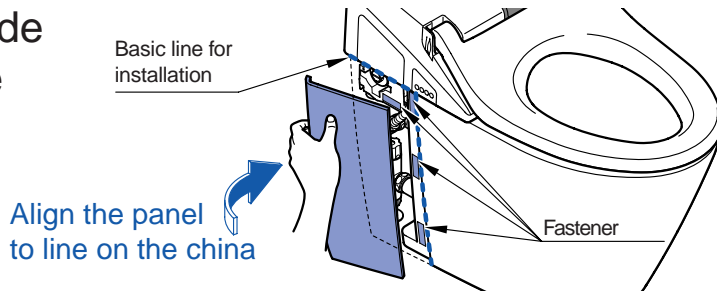

5: Checking the top unit display

Do the POWER light and SEAT light turn on?

Tip

- Refer to the sections on seat on/off or temperature adjusting.

See page 18, 19 for adjusting temp.

You can not use the NEOREST if POWER light is not turn on. (for energy saving [Page 32](#))

If the POWER light is not on, push  to turn in on.

Confirm this!

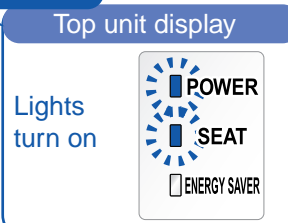

Confirm this!

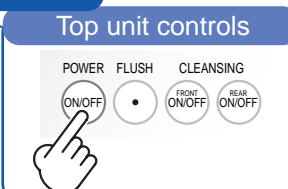

Standard use

1 Approach the NEOREST

↓
The lid opens automatically.

See page 23 for seat and lid open/close

- The NEOREST starts deodorizing.

2 Sit on the NEOREST

Once the NEOREST seat sensor detects someone sitting on the seat, the cleansing and drying features become available.

- When a person sits down, water will flow out of nozzle for several seconds to clear out any cold water and the dryer outlet cover will open and close making an audible sound.

3 Use the cleansing and drying features

Activate the features with the remote control.

Tip

Sit properly on the seat.

If a person is not seated properly while using the cleansing features, water may spatter out of the toilet bowl.

Remote Control Operations

Stop button

Used to stop the cleansing or drying features. The text [STOP] will be shown on the remote display.



Display

Cleaning See Page 17

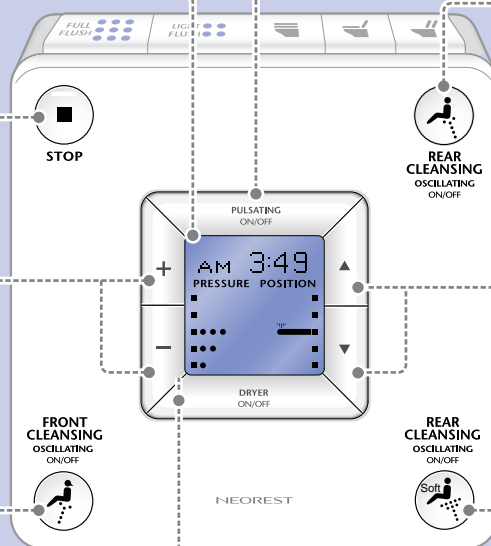

Rear cleansing

Cleaning See Page 17

Activates the rear cleansing feature. The text [REAR] will be shown on the remote display.



Water pressure

Adjust the pressure to one of the 5 levels

Front cleansing

Cleaning See Page 17

Activates the front cleansing feature. The text [FRONT] will be shown on the remote display.



Wand position

Adjust the position to one of the 5 levels

Soft cleansing

Cleaning See Page 17

Activates the rear cleansing feature with soft spray. The text [SOFT] will be shown on the remote display.



Drying

Warm air blows out to dry wet areas. Toilet paper can be used for quicker drying. The text [DRYER] will be shown on the remote display.

Push  to start drying.

Push  again to stop.



4 Get up from the seat

- The nozzle dribbles water for about 30 seconds while extended, then it retracts. The dryer outlet cover will then open and close. The water used for cleansing the nozzle will be drained out.

The toilet bowl is flushed automatically 5 seconds later.

See Page 26, 27 for flush

5 Leave the NEOREST



The lid is closed about 90 seconds after.

See page 23 for seat and lid opening/closing

Additional amenities



Cleansing 1

Oscilating cleansing The nozzle moves back and forth for wide cleansing range

- Push  or  to begin cleansing
- Push the same button again
Oscilating cleansing starts.
- Push it again
Oscilating cleansing stops.

Cleansing 2

Pulsating cleansing Alternates strong/soft water pressure for cleansing

- Push  or  to begin cleansing
- Push 
Pulsating cleansing starts
- Push  again
Pulsating cleansing stops

About seat sensor B

About seat sensor B

- It detects if you are seated on the toilet bowl.
- The sensor gives infrared rays as shown in the figure.
- Its performance may degrade depending on how it is used.

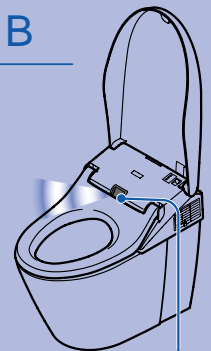

Seat sensor B

Page 50~55

Caution

When the remote control batteries are dead

Please push  and  on the top unit controls to begin cleansing.

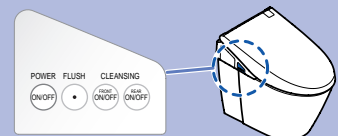

Use

Amenities

1 : Temperature Adjustment

You can adjust the temperature of the water, seat and dryer to your satisfaction with the remote control.

1 Open the remote control cover

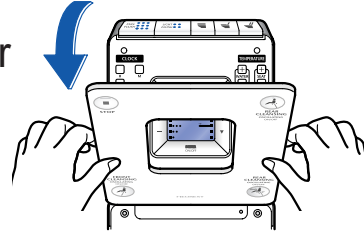

2 Adjust the temperature

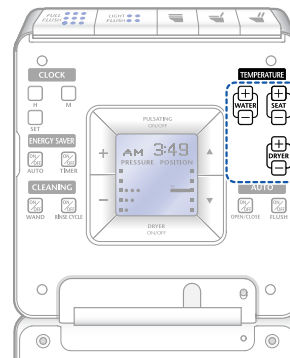

Temperature setting

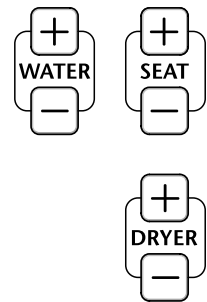

Water temperature

Water temperature buttons
Temperature ranges from
86°-104°F (30°-40°C).

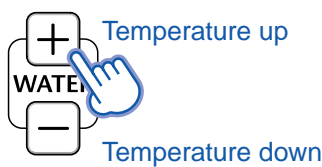

Remote control display
light turns on



These 5 bars show the
water temperature levels.



The clock display will return
5 seconds after a temperature
button is pushed.

- If you want to disable the water heater, push until Water OFF is shown on the display.

Seat temperature

Seat temperature buttons
5 temperature levels.

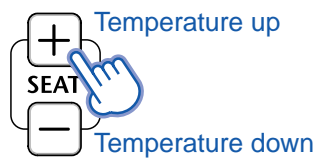

Remote control display
light turns on

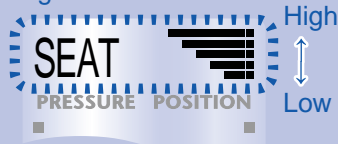

These 5 bars show the
seat temperature levels.

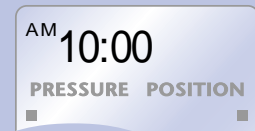

The clock display will return
5 seconds after a temperature
button is pushed.

- To disable the seat heater,
push until Seat OFF
is shown on the display.

Confirm This! Top unit display

When the heater is
ON, the SEAT lamp
will turn on.

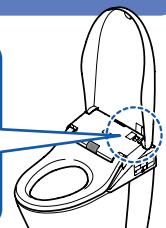
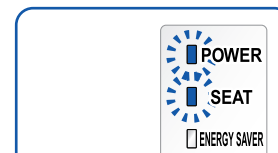

2 Adjust temperature (continued)

Dryer temperature

Dryer temperature button
5 temperature levels.

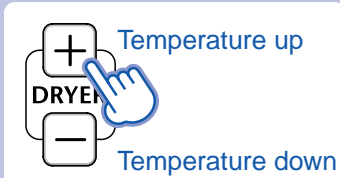

Remote control display
light turns on



These 5 bars show the
dryer temperature levels.



The clock display will return
5 seconds after a temperature
button is pushed.

About the beeping feature

- The top unit will beep when it receives a signal from the remote control. There are 3 types of beeps.
 - “Bik” . . . when a button on the remote control is pushed and the top unit receives the signal.
 - “Beep” . . . when the stop button is pushed or when the energy saver or oscillating feature is turned off.
 - “B-B” . . . when the temperature is set to High

To disable the beeping feature

- 1 Push  on the remote control for 10 second or more (Push it until the display stops flashing)

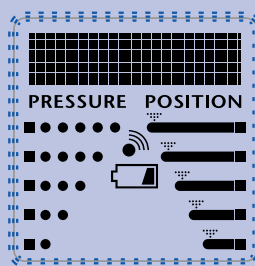

Confirm this!
All fields on the
remote control
are flashing

- 2 Push  . The top unit will beep when it receives the signal from the remote control.

Tip • When the top unit receives the signal from the remote control, it will give a “Bik” sound.

- 3 Push  again

The setting has been changed. The beeping features is disabled. The clock display resumes.



[Current time]

To re-enable the beeping feature, repeat the steps above.



Use

2: Deodorizer

Activating the deodorizer

- How to use the deodorizing function

1 Approach the toilet bowl

The deodorizer turns on automatically

Tip • The deodorizer is initially set to ON.

2 Leave the toilet bowl

The deodorizer stops automatically after about 1 min.

Disabling the deodorizer feature

1 Push on the remote control for 10 second or more (Push it until the display starts flashing)

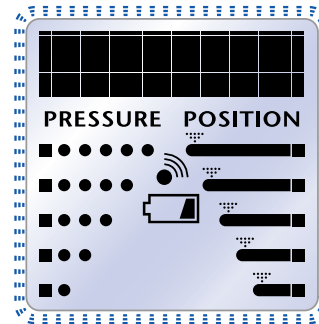
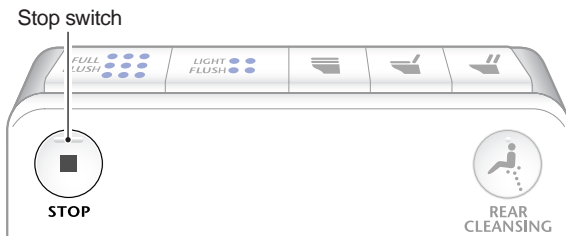

2 Open the remote control cover and push H

- The top unit will beep when it receives the signal from the remote control.

Tip • When the top unit receives the signal from the remote control, it will give a “Bik” sound.

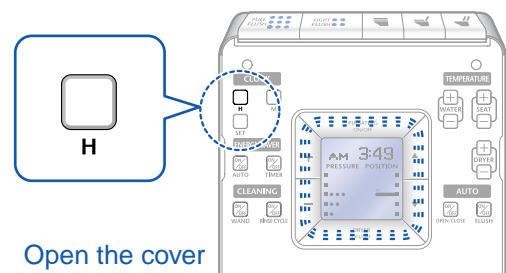

3 Close the remote control cover and push again

The setting has been changed. The deodorizer is disabled. The clock display resumes.

Tip • If the deodorizer is disabled, 10 minutes after the remote control batteries are replaced, the deodorizer will become re-enabled.

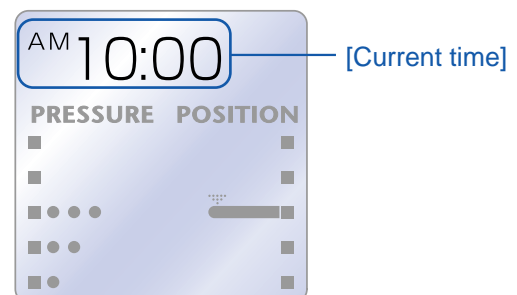

If you want to re-enable the deodorizer, repeat the steps above.

3: Soft Light

The soft light provides a cozy atmosphere and is not meant to replace be the main source of restroom lighting.

When a person sits on the NEOREST

A person comes within 30cm/1ft of the NEOREST

Medium Light



The person sits on the NEOREST

High Light



The person gets up and begins to move away

Medium Light



90 sec after the person has moved more than 30cm/1ft away from the NEOREST, the thelow light shines for 5 secs.

Low Light

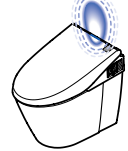

When a person stands in front of the NEOREST

A person comes within 30cm/1ft of the NEOREST

Medium Light



The person stands in front of the NEOREST

Medium Light

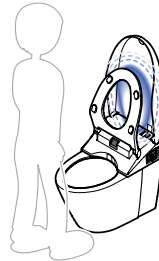

The person gets up and begins to move away

Medium Light



90 sec after the person has moved more than 30cm/1ft away from the NEOREST, the low light shines for 5 secs.

Low Light

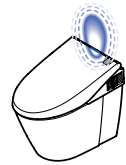

Tip

- The soft light will have the same functionality whether the seat and lid are opened/closed manually, with the remote or automatically.

Changing soft light between low, medium, and high modes

Tip

- Medium Mode is the default mode. Its functionality is described in the section above.
- When the NEOREST is set to High Mode, the soft light will provide High Light where Medium Light is indicated in the above section.
- When the NEOREST is set to Low Mode, the soft light will provided Low Light where Medium Light is indicated in the above section.

1 Push  on the remote control for 10 second or more

(Push it untill the display starts flashing)

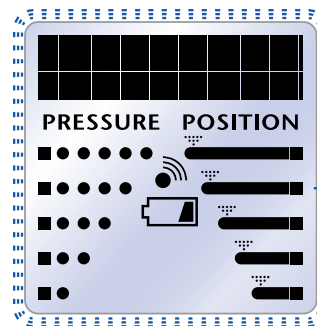
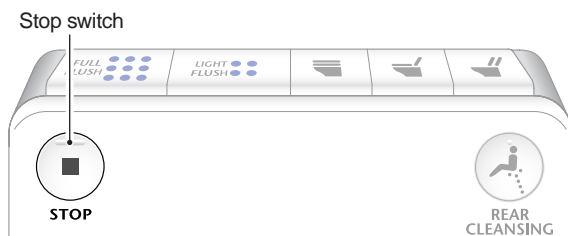

Confirm this!

All fields on the remote control are flashing

2 Open the remote control cover and push  **DRYER**

- Each time the button is pushed, the illumination changes modes. The modes rotate from Low to High to Medium.

Tip

- When the top unit receives the signals from the remote control, it will give out a “Bik” for the Low and High modes, “Beep” for the Middle mode.

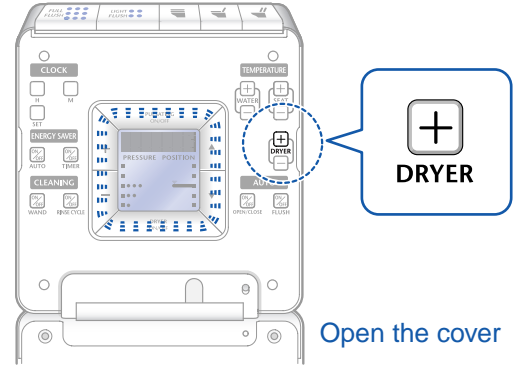
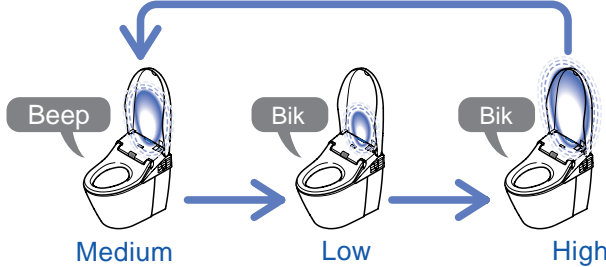

3 Close the remote control cover and push  **STOP** again

The setting has been changed. The clock display resumes.

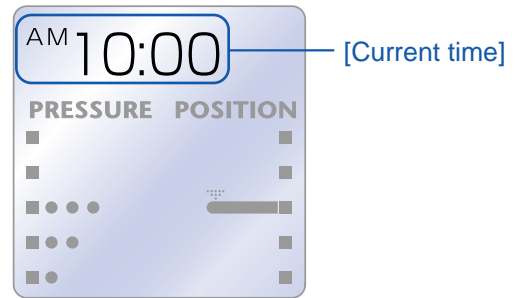

To disable the soft light feature

1 Push  **STOP** on the remote control for 10 second or more (Push it until the display starts flashing)

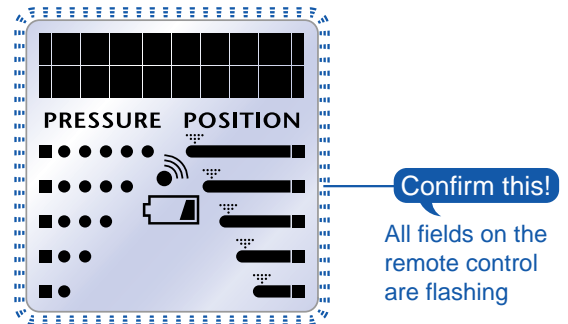
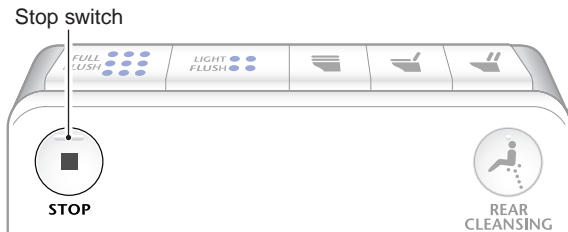



2 Push  **DRYER ON/OFF**

- The top unit will beep when it receives the signal from the remote control.

Tip

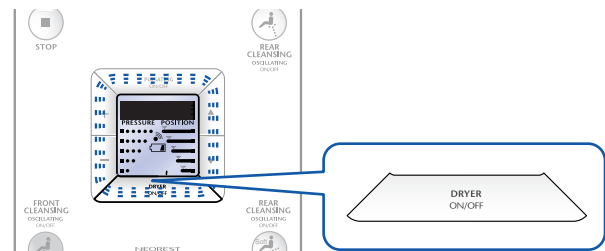
- When the top unit receives the signal from the remote control, it will give a “Bik” sound.



3 Close the remote control cover and push  **STOP** again

The setting has been changed. The soft light is disabled. The clock display resumes.

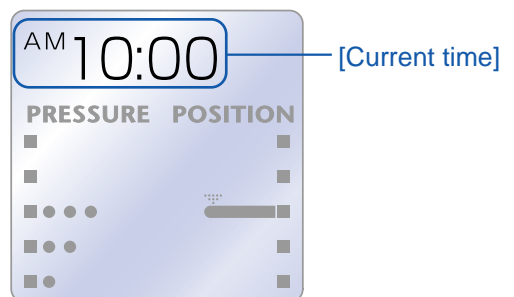

If you want to re-enable the soft light, repeat the steps above.

4 : Seat/lid open/close

The seat and lid can be opened/closed in two ways:

Remote

Auto

How to open/close the seat/lid with the remote control

- You can open/close the seat and lid with the remote control (even if Auto OPEN/CLOSE is set to ON).

Tip • If the remote control batteries are dead, the lid can be opened/closed manually.

Push    on the remote control **Opens/closes the seat/lid.**

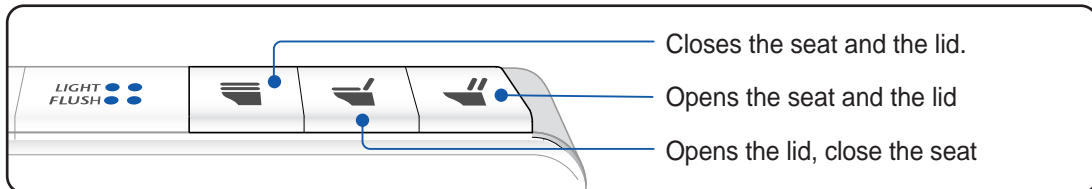

How to use lid auto open/close

- The lid will open automatically when a person approaches and close automatically when they leave. If the lid is closed manually or with the remote control, it will automatically re-open within 2 seconds if someone is still in close proximity. (Do not repeatedly open/close the lid in rapid succession.)

1 Approach the toilet bowl

The lid opens automatically.

Tip

- The lid auto open/close feature is initially set to ON.
- If the room temperature is over 86°F (30°C) seat sensor A can not detect the person because the temperature differential will be too small. In this instance, use the remote control.

- When seat sensor A detects a person, the lid will open automatically.

2 Using the toilet while seated

- The lid opens automatically.
- 90 seconds after a person moves more than 1ft. (30cm) away from NEOREST, the lid will automatically close.

The lid closes automatically.

Using the toilet while standing

- The lid opens automatically. Open the seat with the remote control. [Page 24](#)
- 90 seconds after a person moves more than 1ft. (30cm) away from NEOREST, the lid will automatically close.

The seat and lid close automatically.



Use

Changing the lid auto close waiting time (from 90 seconds to 60 seconds.)

- 1 Push  on the remote control for 10 second or more
(Push it until the display starts flashing)

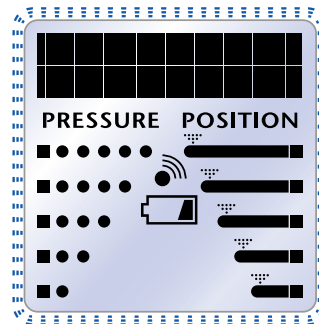
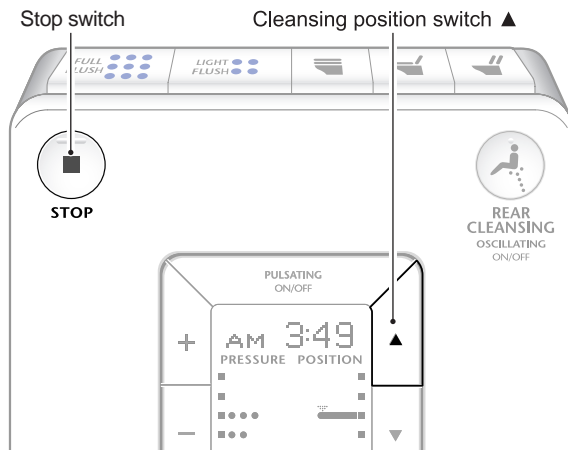

Confirm this!

All fields on the remote control are flashing

- 2 Push 
- When the main unit receives the signal from the remote control, it will give a "Bik" sound.

- The top unit will give out a "Bik" when it receives the signal from the remote control.
- Tip**
- The lid auto close waiting time is changed to 60s, the main unit will give a "Beep" sound when the signal from the remote control is received.

- 3 Push  again

The setting has been changed. The lid will automatically close 60s later. The clock display resumes.



[Current time]

To restore the waiting time to 90 seconds, repeat the steps above.

To automatically open the toilet seat and lid

- 1 Push  on the remote control for 10 second or more
(Push it until the display starts flashing)

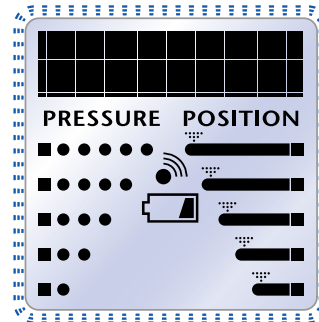

Confirm this!

All fields on the remote control are flashing

- 2 Push 

- When the top unit receives the signal from the remote control, it gives out a “Bik”.

Tip • When switching the automatic open feature to the lid only, the top unit will give out a “Beep” as it receives the signal from the remote control.

- 3 Push  again

The setting has been changed. The seat and the lid will open simultaneously. The clock display resumes.



[Current time]

To restore the automatic open feature to the lid only, repeat the steps above.

How to disable auto open/close

- 1 Open the remote control cover

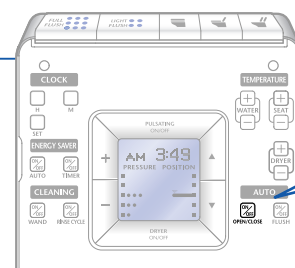

Open the cover

- 2 Push 

- The remote control display shows **ON**
(This is the current setting.)



Confirm this!

[ON OFF]

- 3 Push  again

- The remote control display shows **OFF**



Confirm this!

[ON OFF]

Flashing

Tip • If the button is repeatedly pushed, it toggles
[ON OFF] → [ON OFF]



Use

- On the remote control display shows [AUTO LID OPEN/CLOSE IS OFF]

The setting has been changed. The automatic open/close feature is disabled. The clock display resumes.

To restore the automatic open/close feature, repeat the steps above.

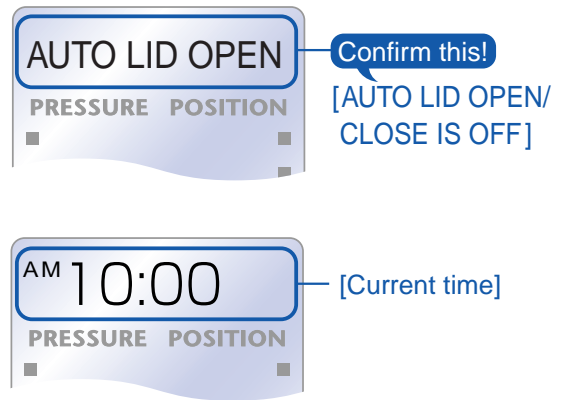

About the NEOREST seat sensors

The NEOREST uses 2 seat sensors.

- Seat sensor A is used to detect a person within 1 ft. (30cm) of the NEOREST.
- It uses changes in temperature for detection. When the room temperature is over 86°F (30°C), the sensor cannot detect a person. Under direct sunlight, erroneous detection may cause the lid open. If the restroom door is open, seat sensor A may be able to detect a person outside the door.
- Sensor B is used to detect a person sitting on or standing in front of the NEOREST.
- It uses an infrared beam for detection.

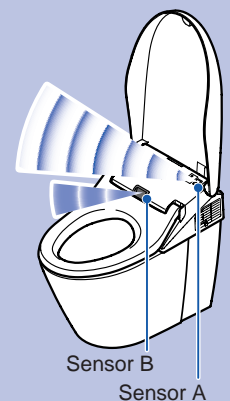

Amenities

5: Flushing

There are two flush modes: **Remote flush** **Auto flush** modes.

Remote flush

- The remote control can be used to flush the NEOREST (even if the auto flush feature is ON).

Tip • 6 seconds must pass after a flush before the NEOREST will respond to a command to flush again.

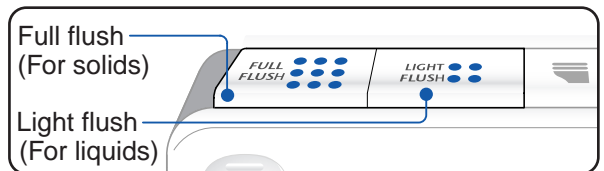

The NEOREST flushes either a full or light flush.

When the remote control batteries dead

- Use flush button on the top unit controls.

Push  on the top unit

The NEOREST flushes a full flush.

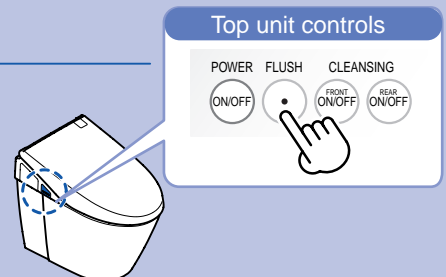

Auto flush

- The NEOREST can flush itself when a person is done using it.
- The auto flush feature is initially set to ON.



When a person sits on the NEOREST

- The NEOREST auto flushes only when a person sits on it for more than 6 seconds.

5 seconds after the person gets up from the NEOREST, it flushes a full flush.

Tip

- If a small child uses the NEOREST, the sensors may not detect him/her and the auto flush may not execute.
- After the NEOREST auto flushes, it will not auto flush for the next 60 seconds. However the remote control can be used to flush.

- The full flush and light flush can be distinguished by the amount of time spent flushing.
Light Flush - approximately 6-30 seconds
Full Flush - over 30 seconds

If a person is not seated properly on the NEOREST, it may flush automatically before he/she has gotten up from seated.

When a person stands in front of the NEOREST

- The NEOREST auto flushes only when a person has been standing in front of it for more than 6 seconds.

3 seconds after the person has gotten more than 1ft (30cm) away from the NEOREST, it flushes a light flush.

Tip

- If a small child uses the NEOREST, the sensor may not detect him/her and the auto flush may not execute.
- After the NEOREST auto flushes, it will not auto flush for the next 60 seconds. However the remote control can be used to flush.



Use

Changing the auto flush waiting time from 5 to 10 seconds.

- 1 Push  on the remote control for 10 second or more
(Push it until the display starts flashing)

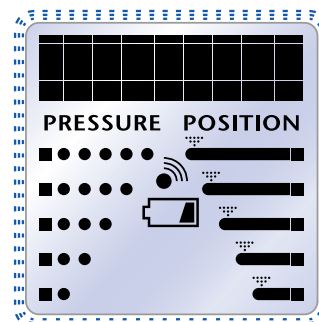
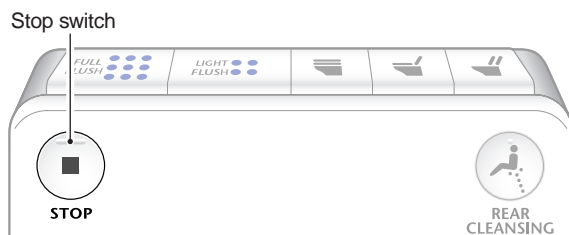

Confirm this!

All fields on the remote control are flashing

2

Open the remote control cover. Push  FLUSH

- When the top unit receives the signal from the remote control, it will give out a “Bik” sound.

Tip

- When switching to a flush waiting time of 5 seconds, the top unit will give out a “Beep” sound when it receives the signal from the remote control.

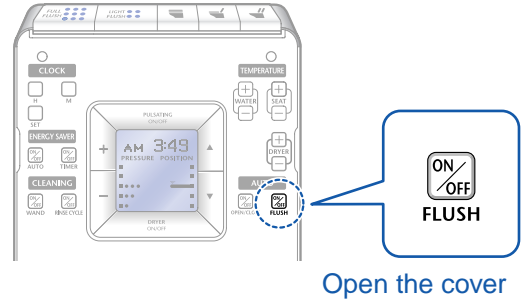

3

Close the remote control cover. Push  again.

The setting has been changed. The auto flush waiting time is 10 seconds. The clock display resumes.

To restore the auto flush waiting time to 5 seconds. repeat the steps above.

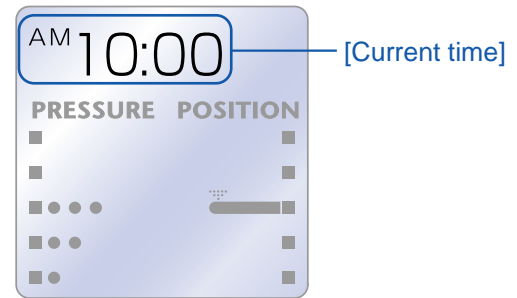

How to flush if there is no power to the NEOREST

- Remove the side panel on the right side of the NEOREST. Turn the flush knob to flush the NEOREST. For more information on the side panel [See page 15, 46](#)

- 1 Turn the knob to the far side for more than 2 seconds
The water in the bowl is flushed.
- 2 After flushing, turn the knob to the near side
The bowl refills with water.

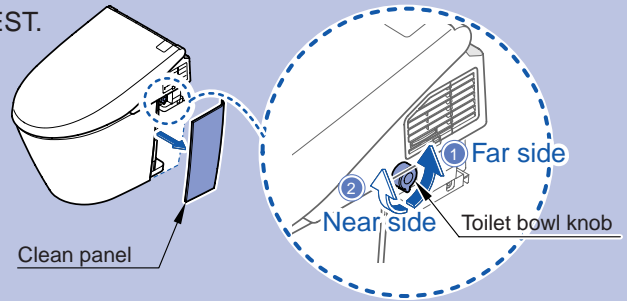

How to disable auto flush

1 Open the remote control cover

2 Push  FLUSH

- The remote control display shows [ON OFF]

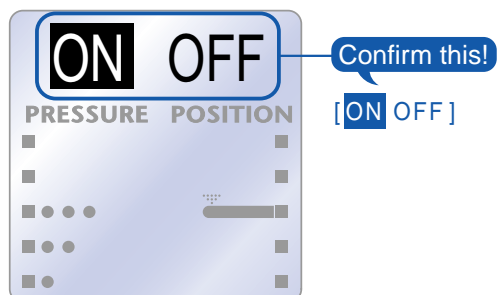
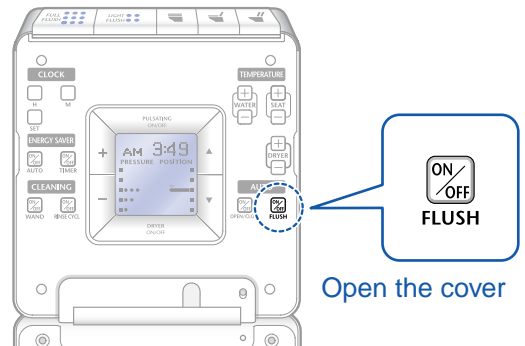

3

Push  again on the remote control

- The display changes to **OFF**

Tip

- If the button is pushed again the display will toggle

[ON OFF] → [ON **OFF**]

- The display then shows [AUTO FLUSH IS OFF.]

The setting has been changed. The auto flush is disabled. The clock display resumes.

To turn the auto flush feature back on repeat the steps above. The display will then show [AUTO FLUSH IS ON.]

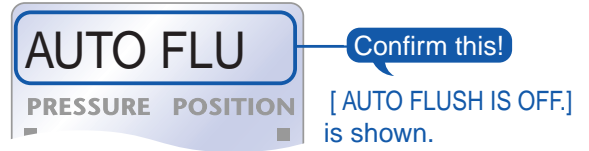
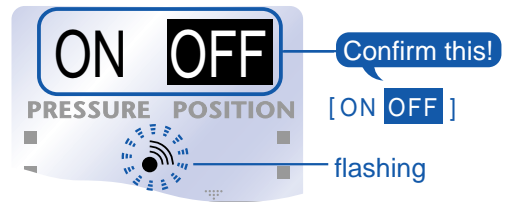

Use

Energy Saving Feature

There are two energy saving modes: timer saver and auto saver.

The timer saver behaves according to the settings entered by the user.

When the time saver is set, the seat heater will automatically shut off every day at the same time for either 3, 6 or 9 hours according to the user's preference.

See page 31, 32 for timer saver

Saving energy!

Example: Set the timer saver from 1:00am to 7:00am (6 hours)

Select 6H starting at 1:00am

Result The seat heater is shut off for a 6 hour period daily.

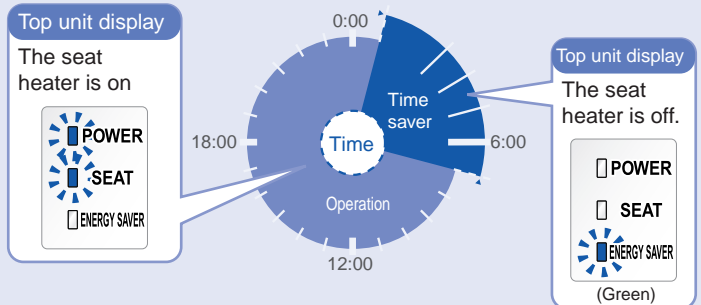

The auto saver determines its own behavior based on stored data.

The NEOREST stores data about when it is being used and determines the ideal periods to automatically reduce the seat temperature based on that data.

See page 33, 34 for auto saver

Saving energy!

Example: The auto saver sets itself from 9:30am to 7:00pm and 11:30pm to 7:00am based on stored data

Turn on the auto saver on the remote control

Result The seat temperature is automatically reduced when the NEOREST is not in use.

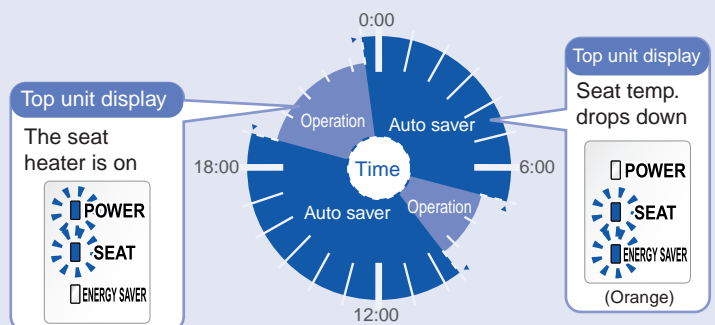

The user can enable the timer saver auto saver simultaneously.

How both features interact when they are both enabled

When timer saver is not activated, auto saver will work.

See page 42 for enabling both

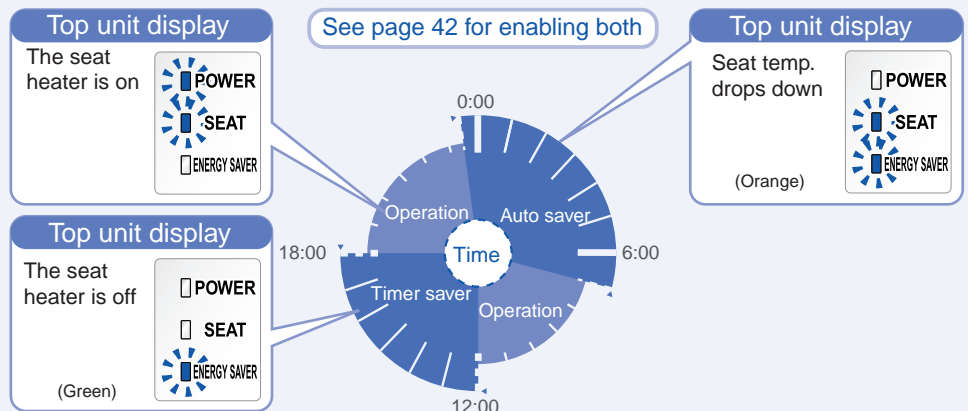

1 : Using the time saver

Example: Set the timer saver from 1:00am to 7:00am (6 hours)

1 Open the remote control cover

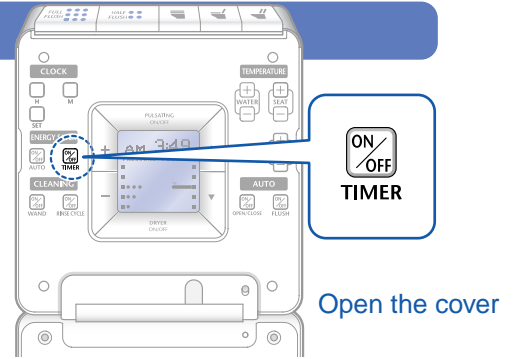

2 Set the required starting time (1:00am), then push **ENERGY SAVER** **ON/OFF** on the remote control.



3 Push **ENERGY SAVER** **ON/OFF** repeatedly until **6H** is shown on the display.

- The text [THE ENERGY SAVE IS SET FOR 6 HOURS] is shown.



The setting has been changed.
The time saver is enabled.

Tip

- When the top unit receives the signal from the remote control, it gives out a "Bik" sound.
- A person can still use the NEOREST during energy saving period.
 - When you sit on the NEOREST, the seat heater is turn back on immediately.
 - It will take about 15 minutes to completely re-heat the seat.

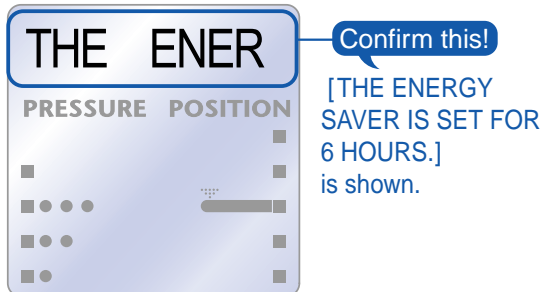

- When the timer saver is activated, [ENERGY SAVER] light (green) will turn on.

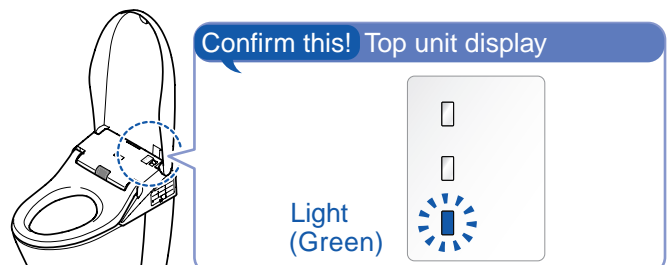

Changing the time saver settings

- The time saver can be set to 3, 6, or 9 hours periods.

1 Open the remote control cover

2 Push **ENERGY SAVER** 

- Pushing the button repeatedly will cause the display will toggle from 3H, 6H, 9H and OFF. Select the appropriate time period.

3 Push **CLOCK**  twice

The setting has been changed.

- While changing the energy saving time period (3, 6 or 9hr), set the starting time as well.

- Tip**
- To change the period during which timer saver is enabled, push **ENERGY SAVER**  at starting time desired.

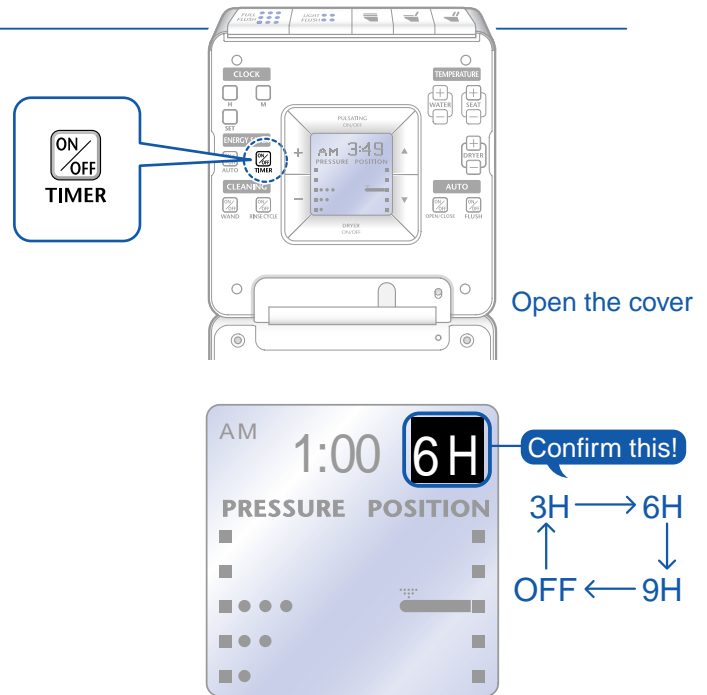

Disabling the time saver

1 Open the remote control cover

2 Push  till [**OFF**] is shown on the display

- The text [THE ENERGY SAVER IS OFF.] will be shown on the remote display.

The setting has been changed. The auto flush is disabled. The clock display resumes.

- The POWER and SEAT lights will turn on on the top unit display.

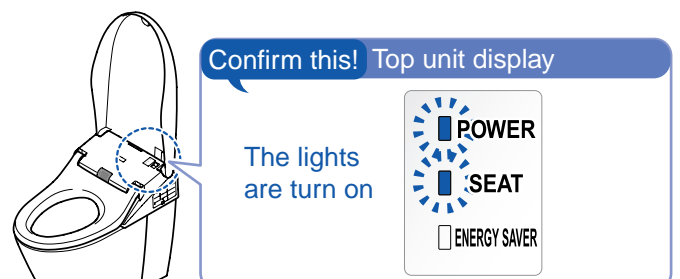
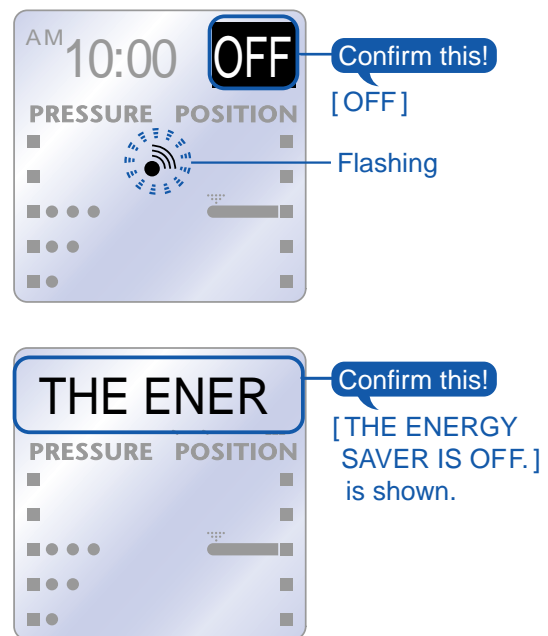

2 : Using the auto saver

Enabling the auto saver

1 Open the remote control cover

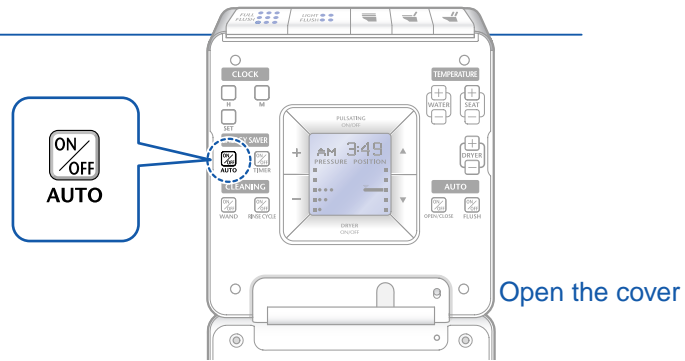

2 Push 

- OFF will be displayed on the remote control (Current setting is shown on the display)

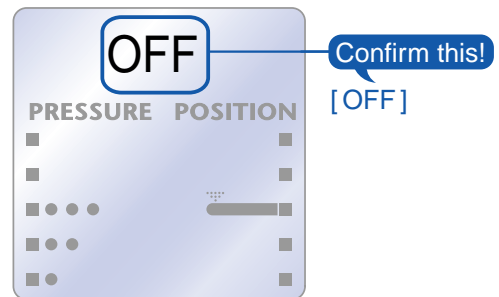

3 Push  until AUTO TIMER is shown on the display

- “AUTO TIMER” is shown on the remote control display.
- The text [THE AUTO ENERGY SAVER IS ON.] is shown on the remote control display.

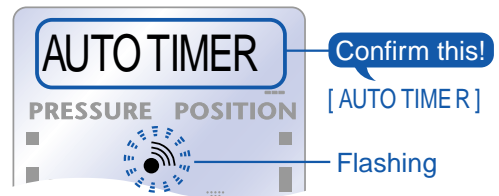

The setting has been changed. The auto saver is enabled. The clock display resumes.

Tip

- It will take 2 or 3 days for the auto saver to collect enough data to determine when it should lower the seat temperature. The auto saver gradually takes effect during that period.
- The NEOREST can still be used even if auto saver has not yet determined when to lower the seat temperature.
 - The auto saver will lowers the seat temperature to 79°F (26°C)when it doesn't expect to be used. The seat will begin re-heating immediately if someone begins to use it during this period.
- While the auto saver has lowered the seat temperature, the SEAT light (green) and the ENERGY SAVER light (orange) will be turned on.

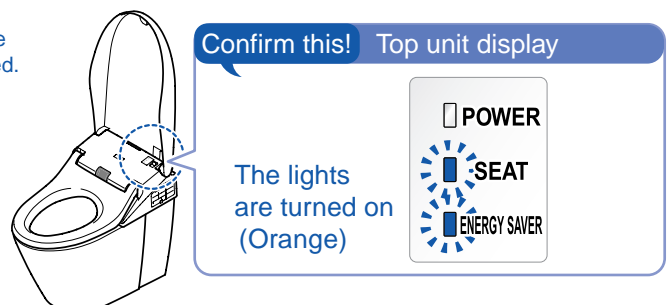

Disabling the auto saver

- 1 Open the remote control cover
- 2 Keep pushing  until OFF appears
 - The information [THE AUTO ENERGY SAVER IS OFF.] will be shown on the remote control display

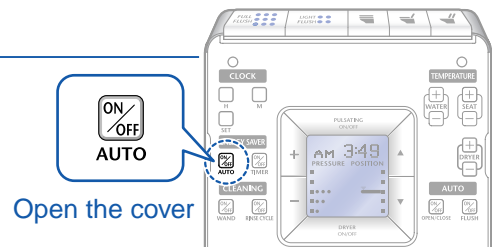

The setting has been changed. The auto saver has been disabled. The clock display resumes.

Confirm this! Top unit display

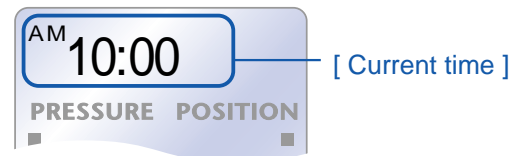
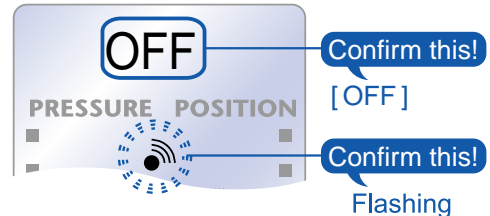
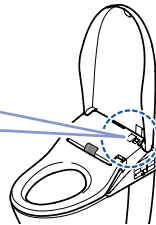
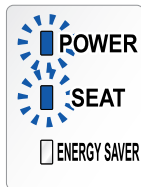

- On the top unit display [POWER] light [SEAT] light are turned on.

Light on



Using the timer saver and auto saver simultaneously

- It does not matter feature you activate first

- 1 Press the  of the remote control to set the timer to the time for starting the energy saving operation See page 31, 32 for timer saver
- 2 Push  to set the auto saver See page 33 for auto saver

Smart energy saving tips

- **Set the seat temperature lower**
Set the seat temperature lower to save energy, but not low enough to not cause discomfort.
- **Close the NEOREST lid**
When the lid is closed, heat is less likely to escape and energy is saved.
- **If the NEOREST will not be used for a long period of time, set POWER ON/OFF to OFF**

Push  to turn off the top unit and save energy.

Maintenance

Maintenance

1: Before Cleaning

Please read before attempting to clean the NEOREST

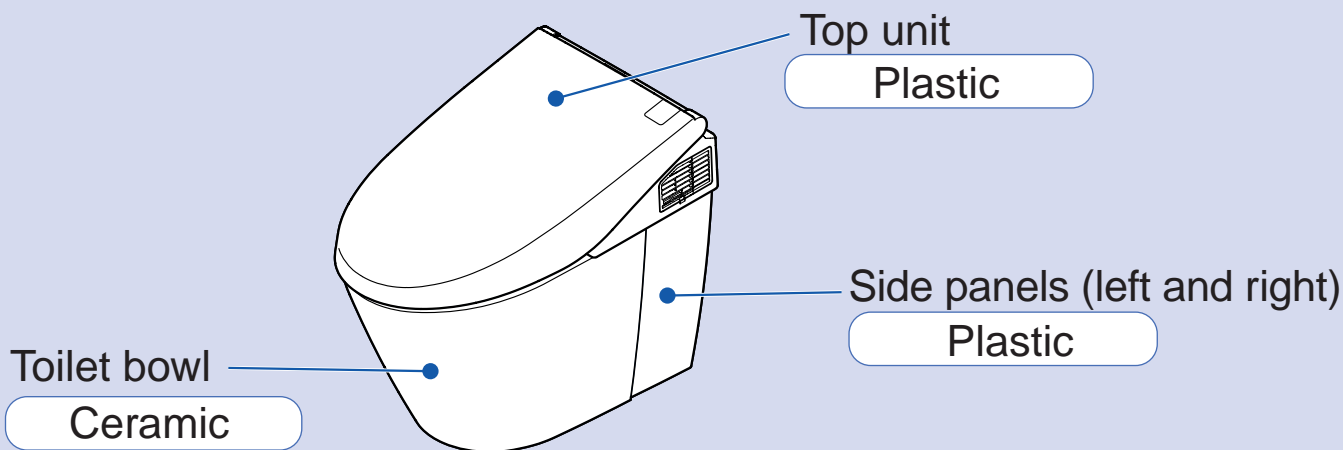

Caution

Improper cleaning can be harmful to the product. Please do not use the following tools or detergents.

Plastic and rubber parts	Thinner, benzene, cleanser, nylon scrubber, dry cloth, toilet paper
Ceramic parts	Strong acid or alkali, abrasive detergent, metal brush, abrasive nylon scrubber
Metal parts	Scrubber, nylon scrubber, cleanser, grounding power, rough detergent, thinner, benzene, chlorine detergent, strong alkaline chemical

Daily maintenance tools (basic)

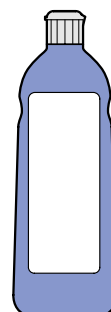

Use



Maintenance

Some parts can be removed for thorough cleaning

Caution

For safety, detach the power plug before cleaning the product.

Detach the power plug when cleaning thoroughly. Basic cleaning can be done while the NEOREST is plugged in. The wand cleaning or rinse cycle features that assist with basic cleaning require power. When the plug is reinserted into the outlet, there will be a 10 second to 1 minute period during which the soft light will flash and auto open/close feature will not be available. However, the seat and lid can still be actuated using remote control.

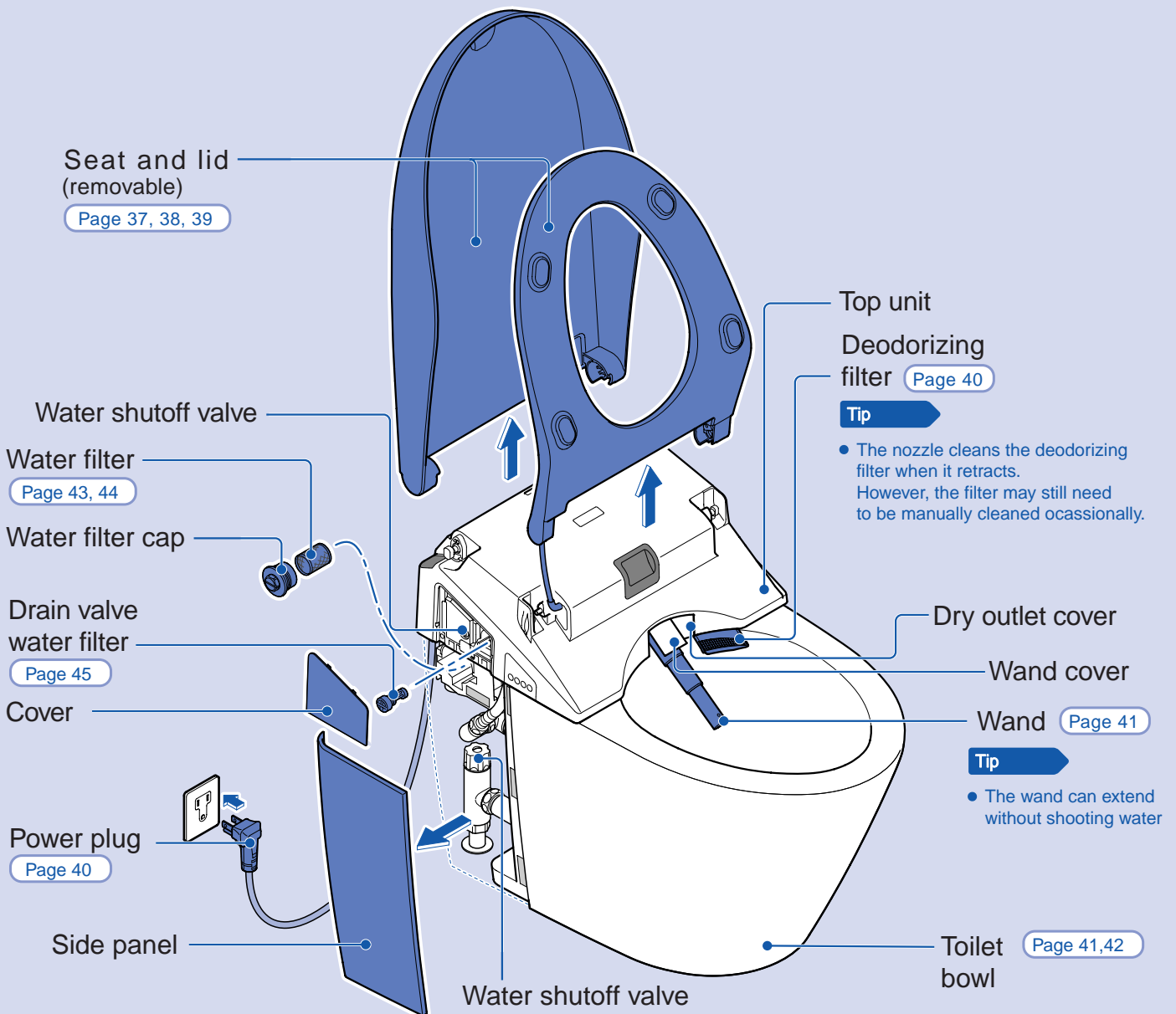

2: Regular Cleaning

Cleaning the top unit, seat and lid

Use a soft damp cloth wet with water to wipe

- The cloth should be wet and any excess water should be rung out before wiping

Tip

- Do not use a dry cloth or dry paper to clean the plastic parts. Using dry paper or dry cloth may degrade the antibacterial coating on some plastic parts.
- The NEOREST is an electrical product. Water should NOT be allowed to seep inside the product. Detergent should NOT be left in any gaps after cleaning.
- Keep the area near seat sensor A and B and the remote signal receiver clean. Dirt in these areas may cause the NEOREST to malfunction.

Page 17, 26, 55

- The curved front of the top unit allows for easy cleaning. The deodorizer filter should not be extended while the curved area is being wiped clean.
- When dryer outlet cover is opened manually, it will not close by itself. Pushing **CLEANING** **ON/OFF** **WAND** will close the dryer outlet cover and open the wand cover for the wand will extend. Pushing **CLEANING** **ON/OFF** **WAND** again will cause the wand to retract.
- Do not use excessive force to push or pull the nozzle cover or dryer cover. (The cover may be damaged or malfunction.)

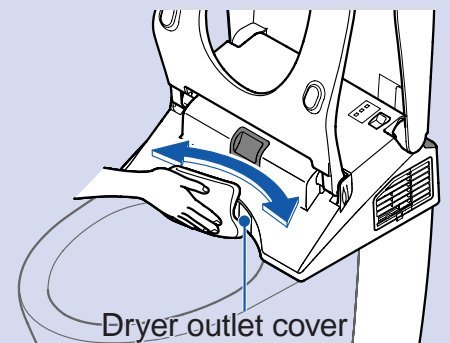
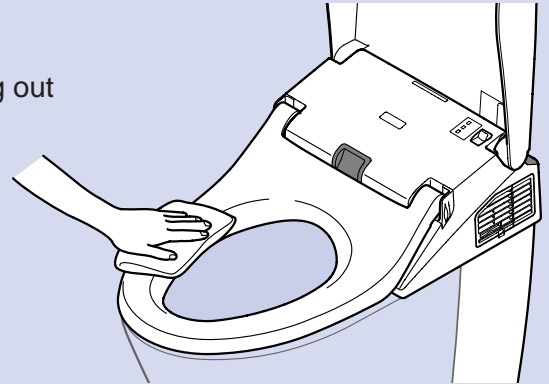

In case of excessive dirt

- Use a soft damp cloth wet with water and a thin neutral detergent to clean.
- Then use a soft damp cloth wet with water only to remove the detergent.

If detergent adheres to the product

- Use a soft damp cloth wet with water to wipe it off.

Cleaning the toilet bowl

- Use a toilet brush or sponge with water to clean the bowl.

Cleaning the floor

- If liquid gets on the floor, use a damp cloth to wipe it up.

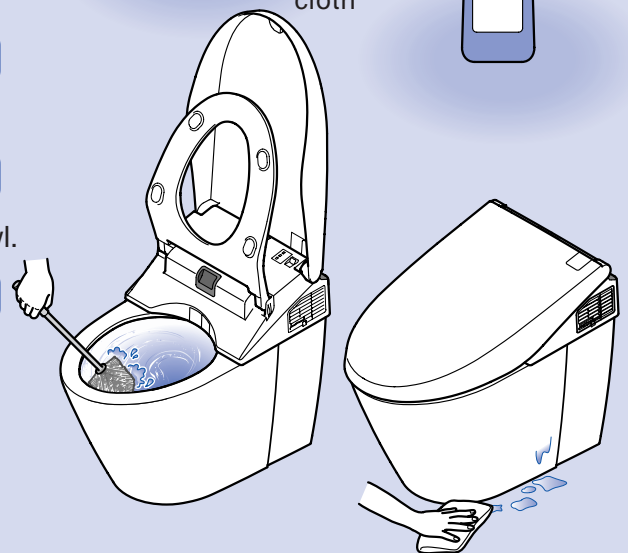
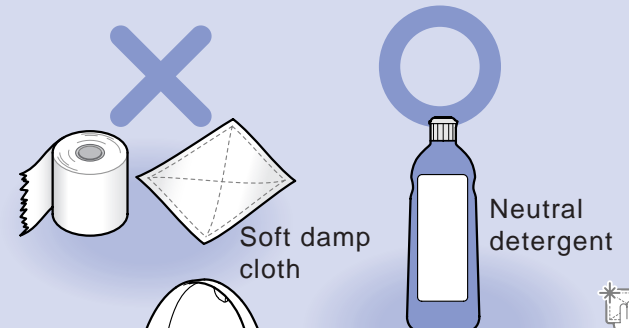

Caution

- If toilet detergent is used in the toilet bowl, keep the toilet and the lid opened while cleaning with the detergent. Rinse off the detergent as soon as possible (within 3 minutes) and be sure to rinse off the detergent thoroughly. (When detergent is evaporates, the fumes may seep into the top unit and cause damage to the product.)



3: Thorough Cleaning

Cleaning the top unit, seat and lid

- Removing the lid for a more thorough cleaning

Removing the lid

1 Remove the lid

Lift the lid as shown in the figure and pull it upward.

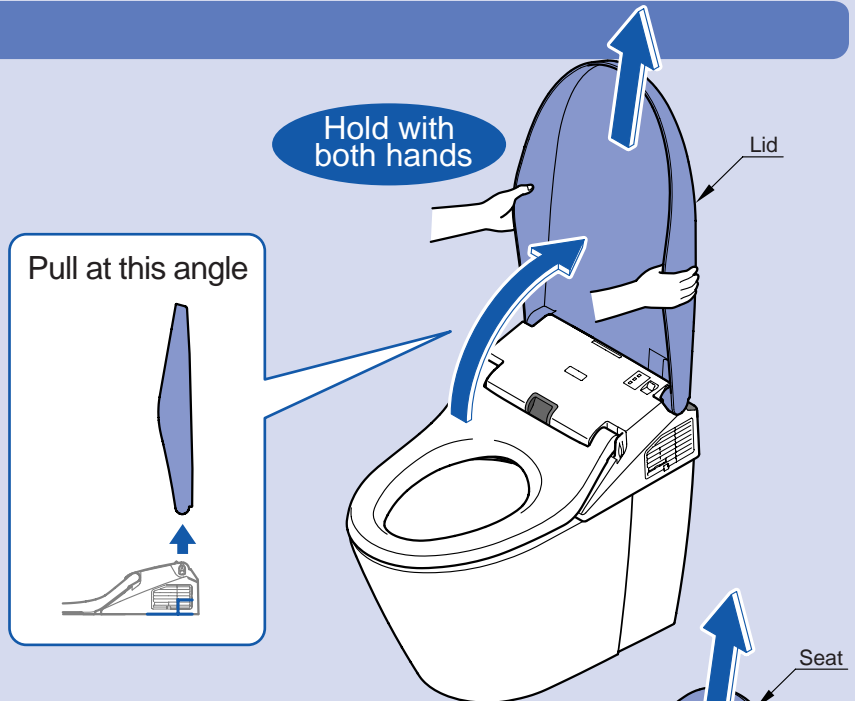

2 Remove the seat

Lift the seat as shown in the figure and pull it upward.

- Do not pull it at an oblique angle or apply excessive force. (Damage may result.)

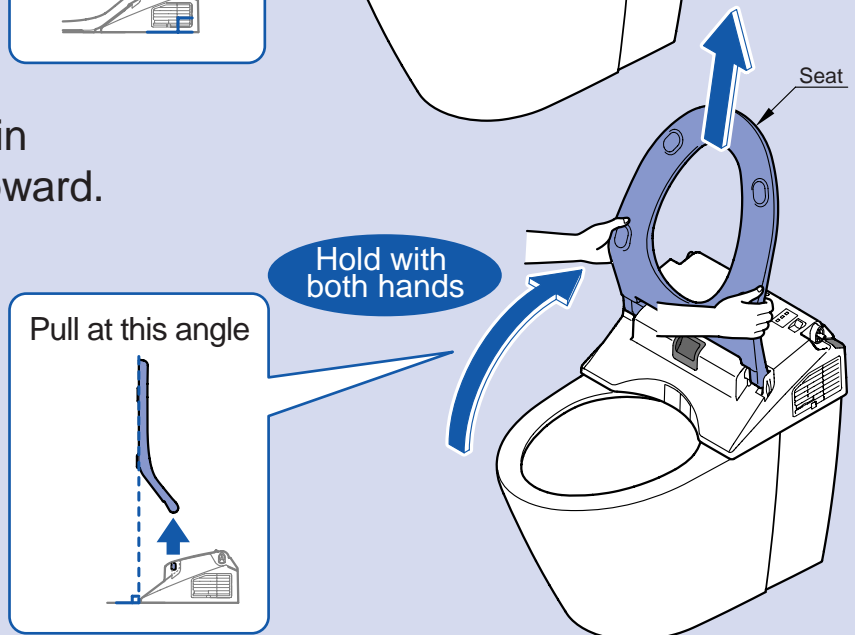

3 Place the detached seat on the toilet bowl

- The cord for the seat is about 3 in. (8cm). Do not pull on it. (The cord may break.)

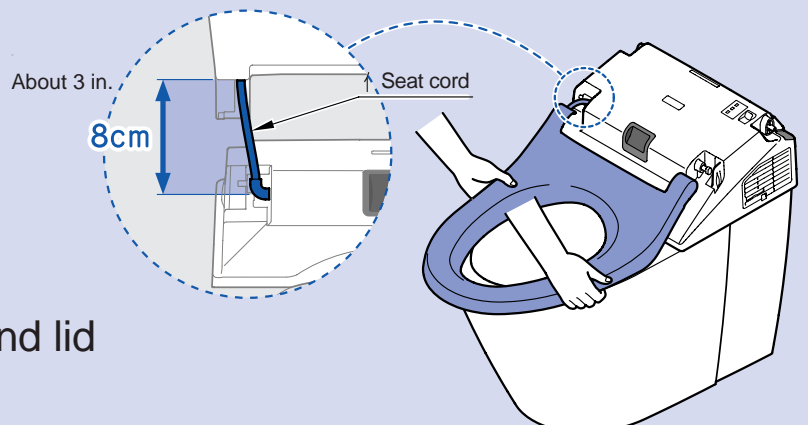

4 Clean the top unit, seat and lid

See page 37 for cleaning instructions

Installing the seat and lid

1

Confirm the seat pin and lid pin are in a vertical position.

- ※ If the pins are not vertical, use a wrench to adjust them. It is important that the pins be vertical.

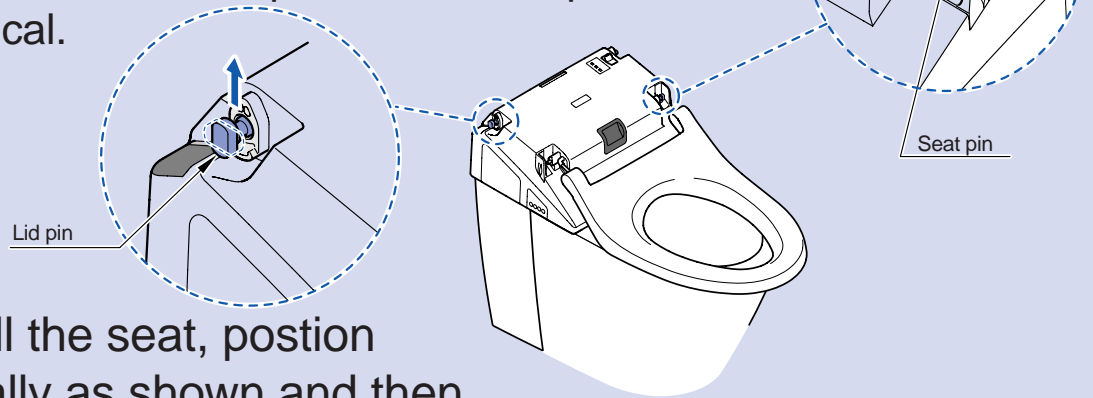

2

To install the seat, position it vertically as shown and then lower it onto the pins.

- If the seat and pins are vertical, the seat should easily slide into place. Do not use excessive force.
- The seat cord should not be twisted.

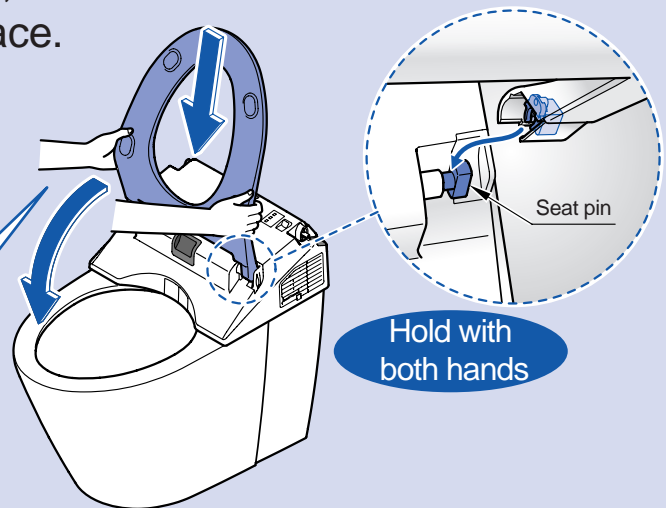
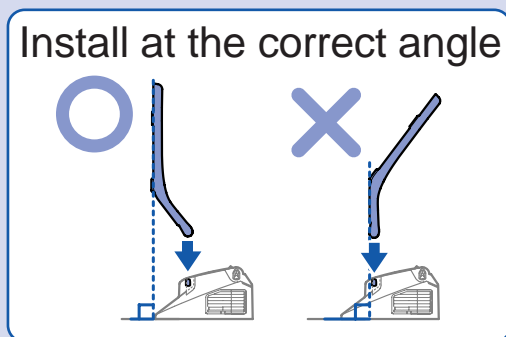

3

To install the lid, position it vertically as shown and then lower it onto the pins.

- If the lid and pins are vertical, the seat should easily slide into place. Do not use excessive force.

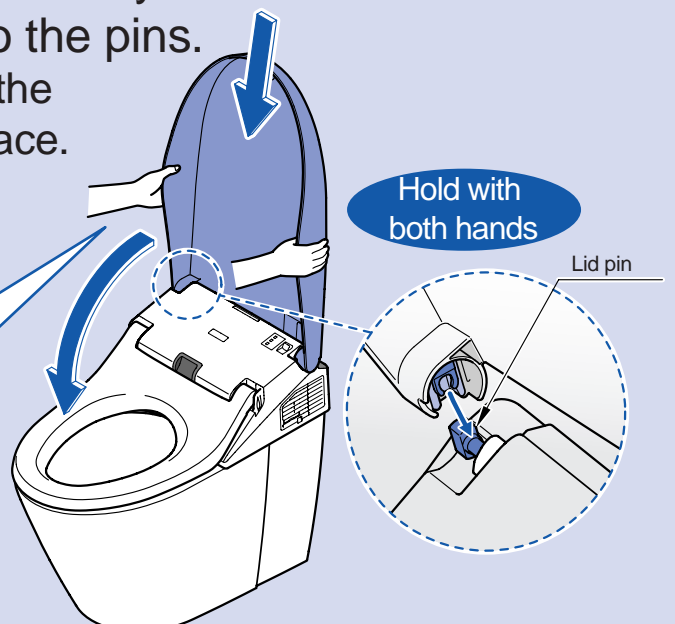
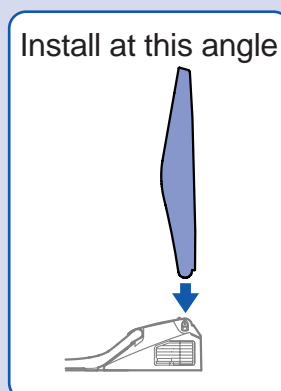

4: Routine cleaning

Checking and cleaning power plug

- Please clean the power plug every month.

- 1 Remove the power plug from the outlet
- 2 Clean it
 - Use a dry cloth to clean off any dirt on the plug.
- 3 Re-insert the plug
 - Be sure to insert it firmly and securely into the outlet.

Cleaning the deodorizer filter

- Clean the deodorizer filter if an odor becomes present

- 1 Hold the deodorizer filter by its knob and pull it out
 - Do not use excessive force. (damage may result.)
 - Do not completely remove the deodorizer filter.
- 2 Clean the filter
 - Use a toothbrush to clean off any dust on the filter.
- 3 Push the deodorizer filter back into position
 - Push it until there is a CLICK noise to ensure it is reinserted properly.

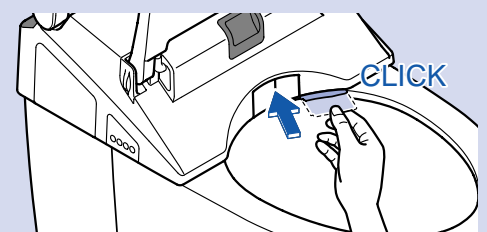
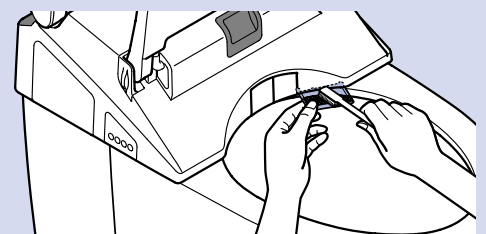
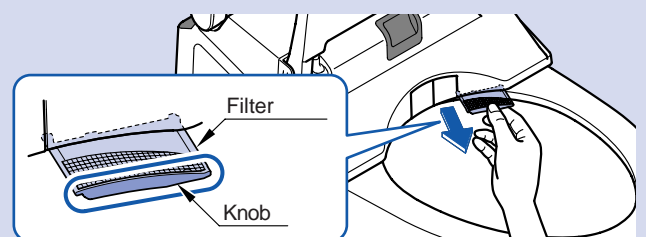

Cleaning the wand

- The nozzle can extend without shooting water, so that it can be cleaned easily.

- 1 To make the wand extend, open the remote control cover.

Push  WAND

- The dryer outlet cover will open and close, making an audible sound.

Wand extends

- Water dribbles out to clean the base of the nozzle.
- The nozzle will draw back automatically after about 5 minutes.

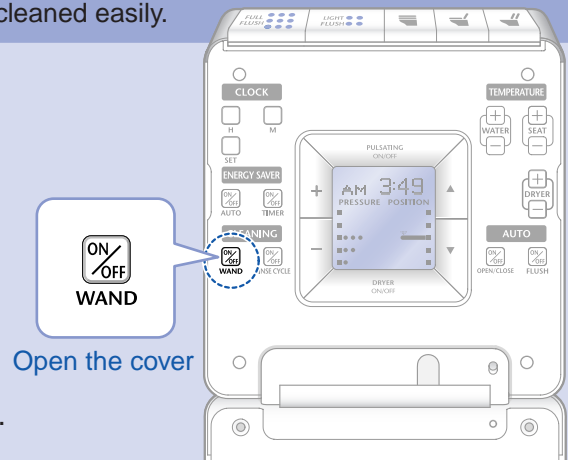

Open the cover

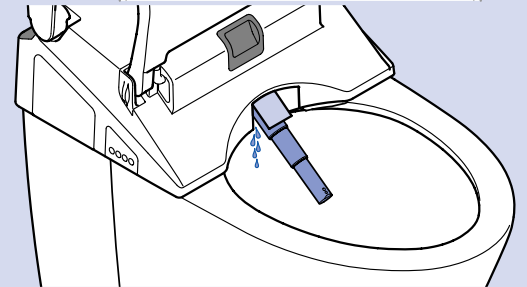

- 2 Clean the wand

- Use a soft cloth wet with water to clean the nozzle. Do not use excessive force to pull, push or press the nozzle. (A damage may result.)

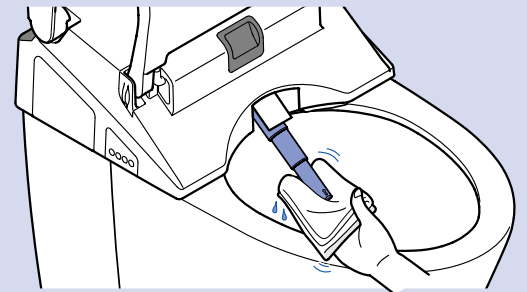

- 3 To retract the wand

Push  again

The wand retracts and auto cleanses.

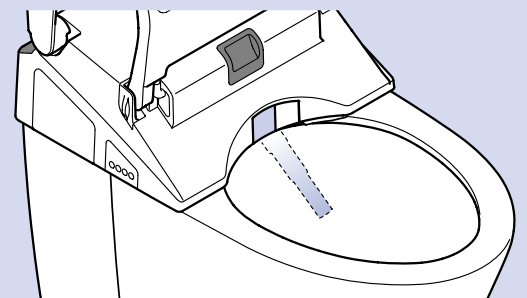

Cleaning the toilet bowl

- The rinse cycle allows for easy cleaning. Be careful to not to damage the top unit with detergent

- 1 Open the remote control cover

Push  RINSE CYCLE

- Begin cleaning the toilet bowl.

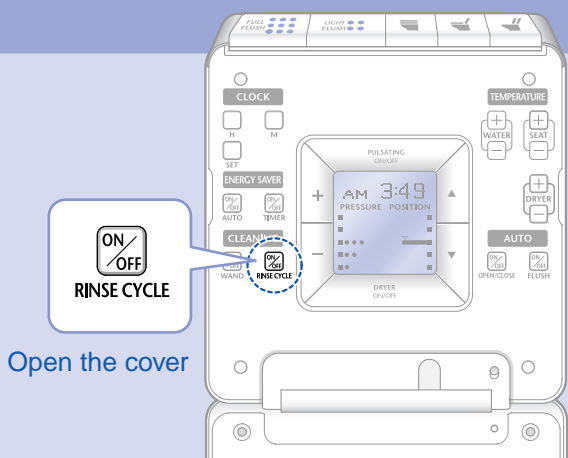

Open the cover



2

The rim wash runs continuously for 30 seconds.

- Now clean the sides of the toilet bowl.

Push  to move on to **3** before 30 seconds

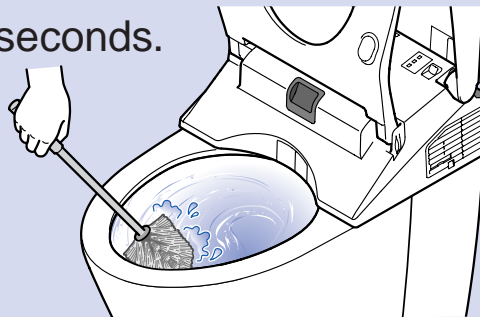

3

The siphon jet runs continuously for 30 seconds.

- Now clean the trap way portion of the toilet bowl.

Push  to move on to **4** before 30 seconds

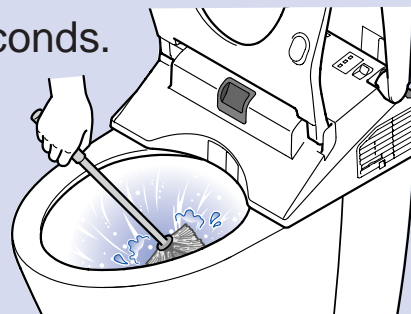

4

The toilet bowl is refilled with water

- The rinse cycle is complete.

Clean Toilet bowl!

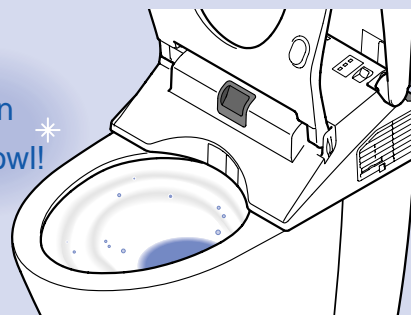

To stop cleaning in the middle of the rinse cycle

Push  . The NEOREST will flushed and refilled

Caution

If detergent is to be used, use it before cleaning with the rinse cycle

- When detergent is used to clean the toilet bowl, rinse it off soon as possible (within 3 minutes). Keep the seat and lid opened while detergent is in the bowl. Be sure to rinse off the detergent thoroughly. (Detergent fumes may enter into the top unit and cause damage to the product.)

Tip

- If the interior of the toilet bowl become visibly dirty, clean it immediately.

If the side panels are accidentally removed during cleaning

See page 15 and 44 for instructions on how put on the side panels

Cleaning the water filter



- When the flush becomes weak, clean the water supply filter and the drain valve water filter.

Use the attached special tool to access the water supply filter

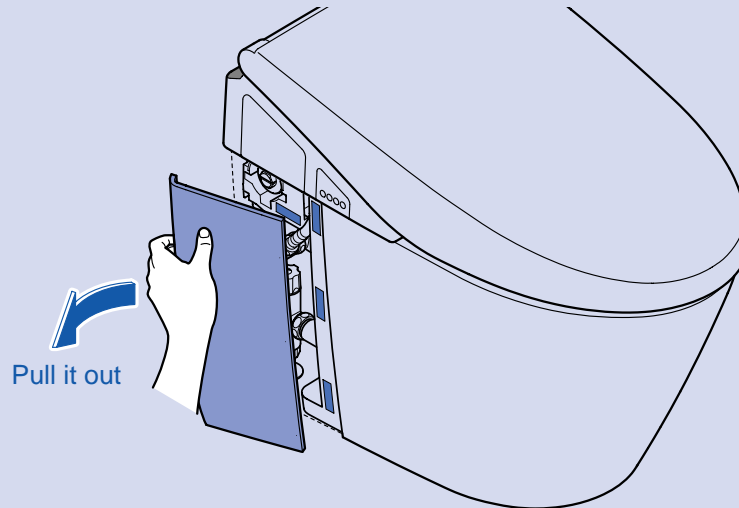
- 1 Hold the rear part of the side panel and pull it off.



- 2 Turn off the water supply using the water shutoff valve

- Push  to make the wand extend.
- Push  again to make it retract.
(this is to release the water pressure inside NEOREST.)

⚠ Caution



Do not

Do not attempt to remove the water supply filter if the water shutoff valve is open. Water will spray out.

water supply on the floor

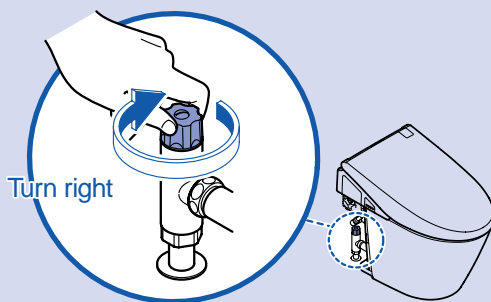

water supply on the wall

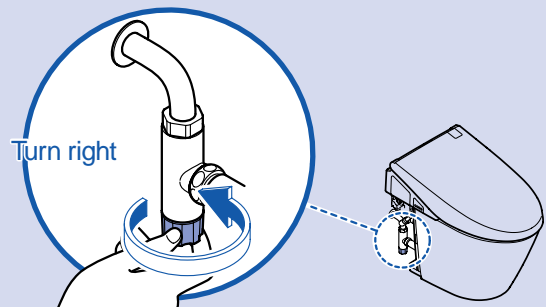

- 3 Remove water supply filter

- Use the special tool to remove the water filter cap.
- Then remove the water supply filter.

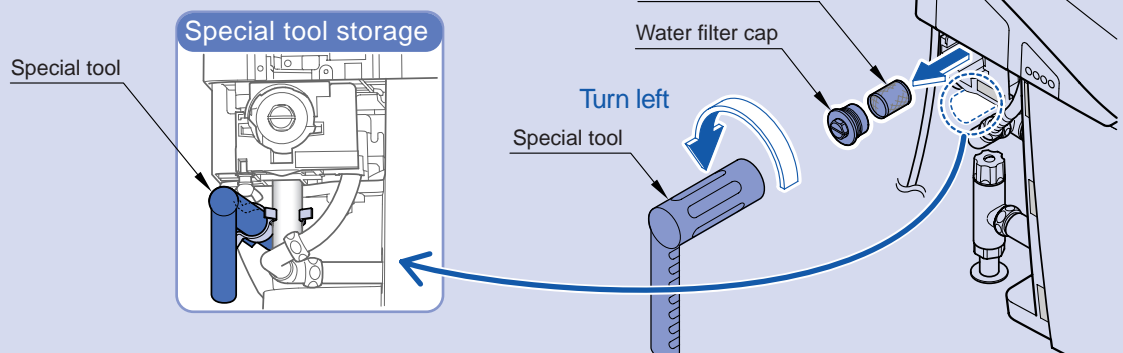

Maintenance

4

Clean the water supply filter

- Clean off any dirt that has adhered to the mesh.
- Use toothbrush to remove any residual dirt.

Tip

- When cleaning the water supply filter
- Use water only. No detergent.
- Do not use excessive force. The filter may become deformed.

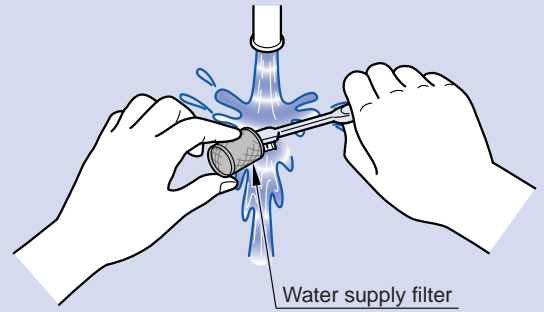

5

Replace the water supply filter

- Restore the parts in their position original, use the special tool to fasten the filter cap.

⚠ Caution



Fasten the filter cap firmly

Mandatory

- A loose water filter cap will cause water leakage.

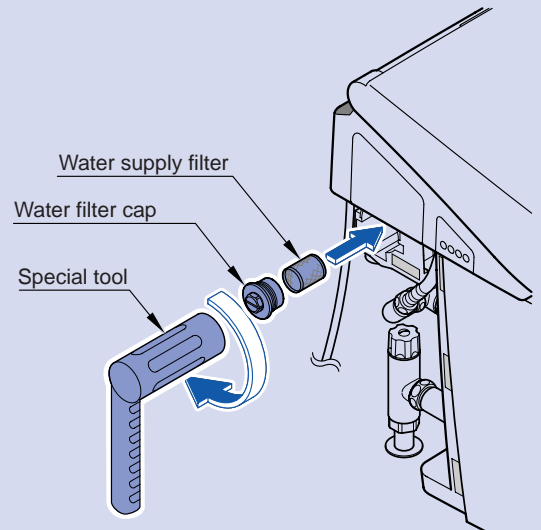

6

Open the water shutoff valve

- Confirm there is no leakage from the water shutoff valve and pipe.

water supply on the floor

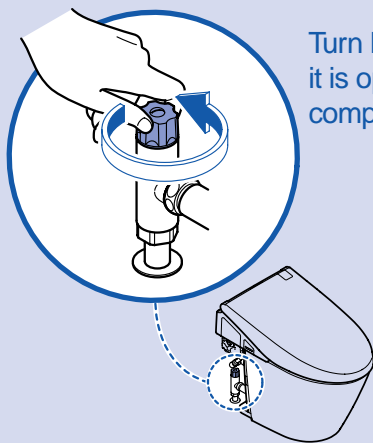

water supply on the wall

Turn right until it is opened completely

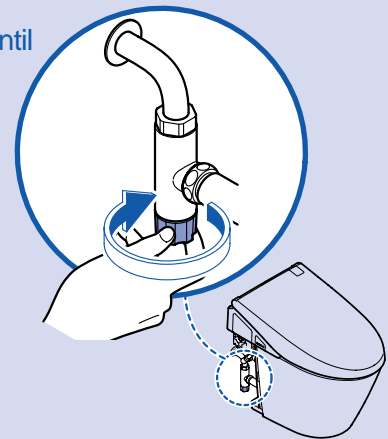

7

Keep the special tool in its designated place, align the side panel with the basic line and then re-install it

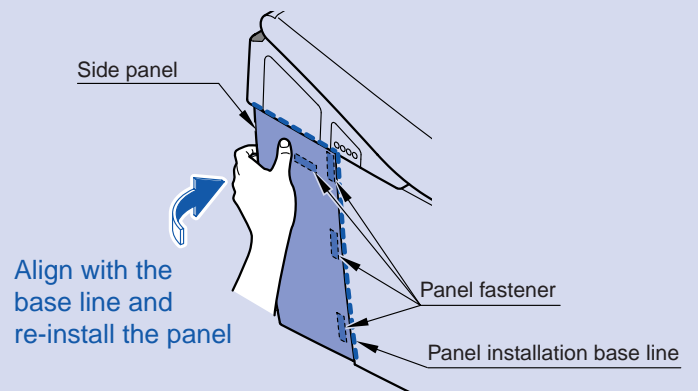

Cleaning the drain valve water filter

1 Turn off the water supply using the water shutoff valve

Page 43

2 Remove the cover on the side of the top unit

3 Remove drain valve water filter

- Loosen the drain valve water filter with ⊖ screw driver, and then pull it out.

⚠ Caution



Do not

Don't remove drain valve water filter if the water shutoff valve is open. Water will spray out.

4 Clean the drain valve water filter

- Use a toothbrush to remove any dirt.
- Use a cotton swab to remove the dirt in the drain valve water filter holes.

Tip

- When cleaning the drain valve water filter
 - Use water only. No detergent.
 - Do not use excessive force. The filter may become deformed.
 - Do not break the filter when removing it.

5 Re-install the drain valve water filter

- Insert the regulation valve, use a ⊖ screw driver to fasten it firmly.

⚠ Caution



Mandatory

Fasten the drain valve water filter firmly

- A loose installation will cause water leakage

6 Re-Install the cover

7 Open the water shutoff valve

Page 44

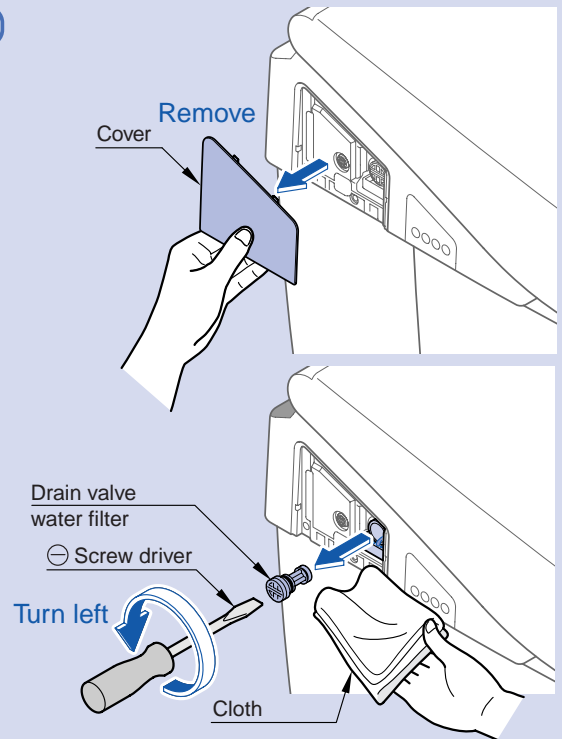

Remove

Cover

Drain valve water filter

⊖ Screw driver

Turn left

Cloth

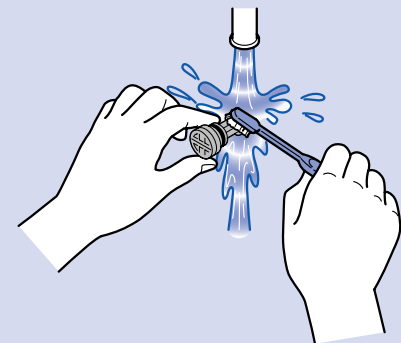

Drain valve water filter

Turn right

⊖ Screw driver

Close the cover

Cover



Maintenance

Power or water failure

Power or water failure

- The NEOREST will not flush properly if there is power or water failure. In such a situation, follow these instruction.

Power failure

How to flush the NEOREST if there is a power failure

- Remove the cover panel on the right of the NEOREST, use the manual flush knob

If the side panels are accidentally removed [see page 15, 44, 45](#)

- 1 Turn the knob to far side for more than 2 seconds.

The water in the bowl is flushed.

- 2 After flushing, turn the knob to near side

The bowl refills with water.

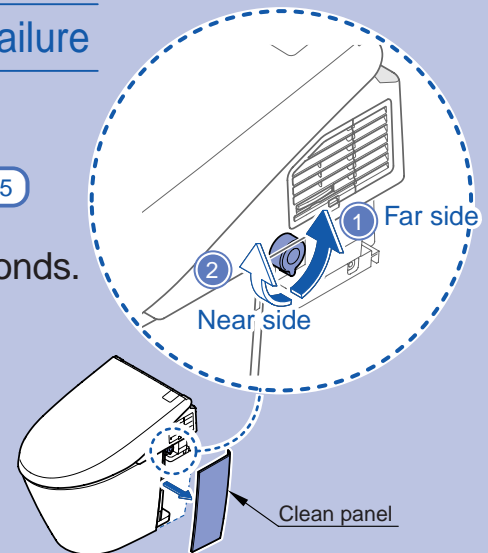

Water failure

- Tip** • If the water supply fails, please the set auto flush feature to OFF.

[See page 28, 29 for disabling auto flush](#)

- Pour about 2gal.(8L) of water from a big bucket into the center of the toilet bowl to induce flushing. Be careful to not splash water from the toilet bowl.

- Tip** • Cover the floor with newspaper help contain water splashing.

- If the water level is too low in the toilet bowl after the bucket is poured, add more water. The water prevents odors from coming out of the sewer pipes through the toilet bowl drain.

Preventing damage caused by freezing conditions or by disused over an extended period of time

Solution

1 : If freezing conditions are likely

Tip

- If freezing conditions are likely Do not use energy saver. Otherwise the freezing conditions may cause product damage.

See page 32 for timer saver

See page 34 for auto saver

To cope with freezing conditions, use a heater in the room or drain out the water in the toilet bowl. Freezing may cause product damage or leakage.

Caution

To cope with freezing conditions, set **AUTO** **ON/OFF** OPEN/CLOSE **ON/OFF** FLUSH to off and close the seat and lid.

Enabling antifreeze mode

- The NEOREST will flush regularly to drain out the water before it freezes.

- 1 Push **STOP** on the remote control for 10 second or more (Push it until the display starts flashing)

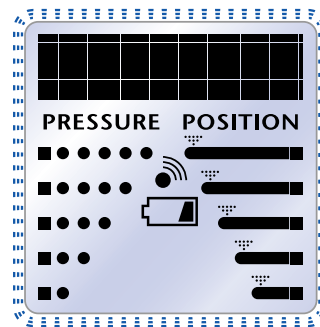
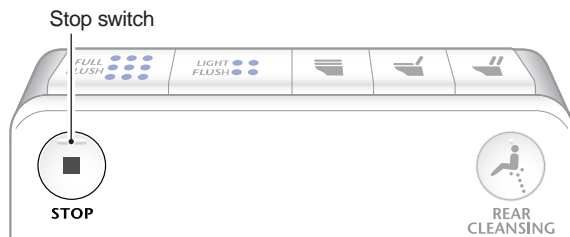

- 2 Open the remote control cover Push **ENERGY SAVER** **ON/OFF** TIMER

- When the top unit receives the signal from the remote control, it will "Beep".

Tip

- When the top unit receives the "OFF" signal from the remote control, it will "Beep".

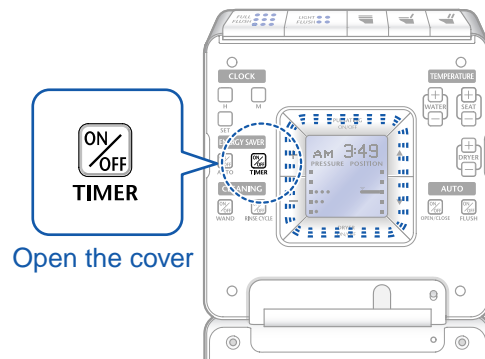

Maintenance

Solution

3 Close the remote control lid

Push  again

The setting has been changed.
The antifreeze mode is on.
The clock display has resumed.

- POWER light on the top unit flashes indicating antifreeze mode is ON.
- About 0.0026gal (50ml) of warm water will flow out of the wand nozzle every 5min.
- The NEOREST is flushed every 10 minutes.

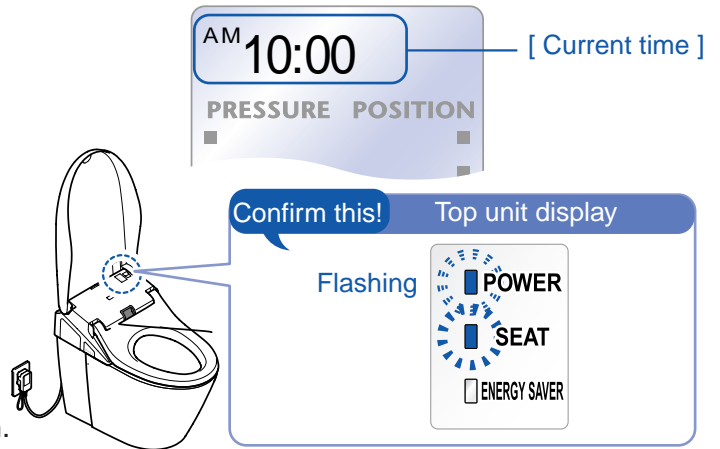

Preventing freezing

- Set the warm water temperature and seat temperature to High on the remote control.
- Close the toilet bowl lid.

Disabling antifreeze mode

- Turn OFF antifreezing mode, repeat the steps above
- See page 47, 48 antifreeze action
- The POWER and SEAT lights will stop flashing when the antifreezing mode is turned OFF

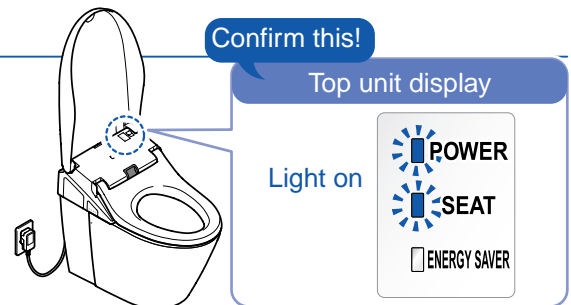

Solution

2 : If the NEOREST is not being used for an extended period of time

- Stagnant water may cause skin irritation or may damage the product. Drain out the water to prevent this.
- If the unit is moved to another location, you should drain out the toilet bowl to prevent freezing.



Drain out the water

1 Turn off the water supply using the water shutoff valve

2 Drain the water in the pipe

• Open the NEOREST lid

1 Remove the cover

- Push  to extend the wand, then push  again to retract it.

(This releases the pressure in the pipe.)

2 Loosen the water supply filter with a ⊖ screw driver, then pull it out.

⚠ Caution

 Do not attempt to remove the water supply filter if the water shutoff valve is open. Water will spray out.

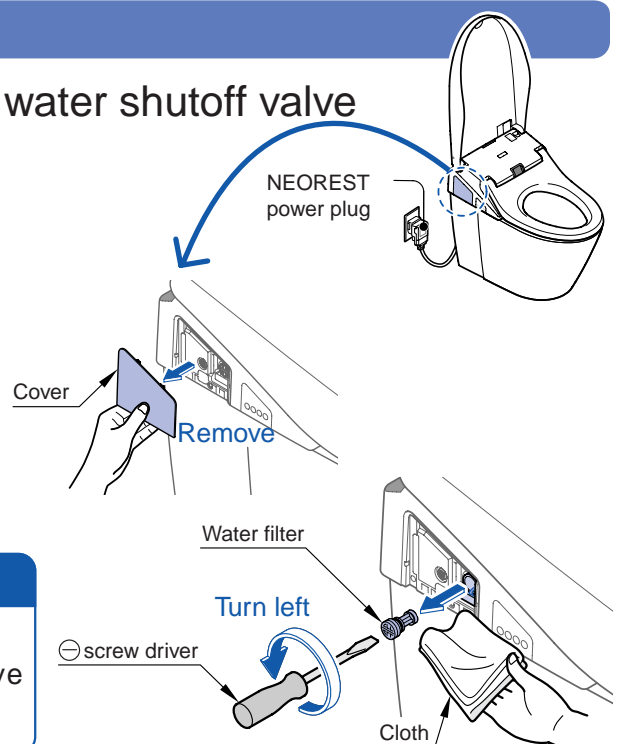

- When the water is drained, put the water supply filter into its place and use the ⊖ screw driver to fasten it firmly.

Caution

Mandatory

- Fasten the filter cap firmly
- A loose water filter cap will cause water leakage

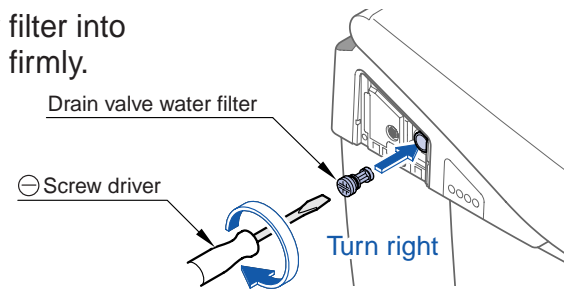

3 Drain the water from in the wand

- Push **ON/OFF WAND** on the remote control
- When water has been drained out, push **ON/OFF WAND** again (Then the nozzle retracts to its original position.)



4 Drain out the water in the top unit

- Keep pushing the drainage lever
 - About 0.11gal.(40ml) of water flows out from the top unit into the toilet bowl. It will take 10 seconds for the water to drain out completely.
- Release the drainage lever. The lever returns to its original position.

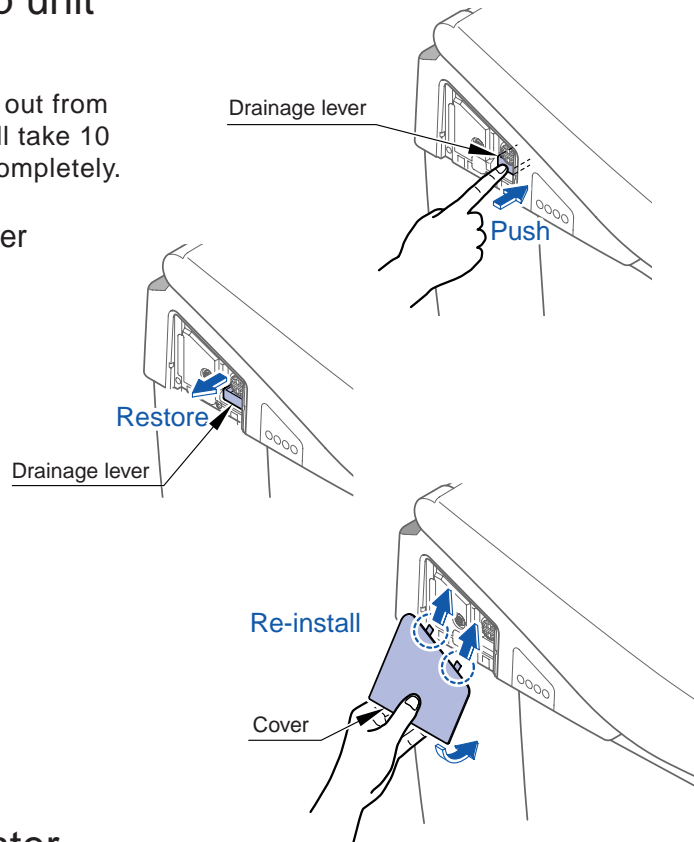

- Re-install the cover

5 Detach the power plug

6 Take care of any retained water

Tip • It is advisable to add an antifreeze agent to the retained water.

To restore water when water has been turned off

1 Open the water shutoff valve

- Confirm there is no leakage in the pipe or in the top unit.

2 Insert the power plug into the outlet

3 Operate wash function

- Cover the seat sensor with piece of paper, have a paper cup ready to catch the water

and push  on the remote control. Allow water shoot out of the nozzle for at least 2min.

Troubleshooting

When there is a trouble with the NEOREST, please read this section to find a solution.

⚠ Caution



Mandatory

If leakage occurs, close the water shutoff valve to cut off water flow.

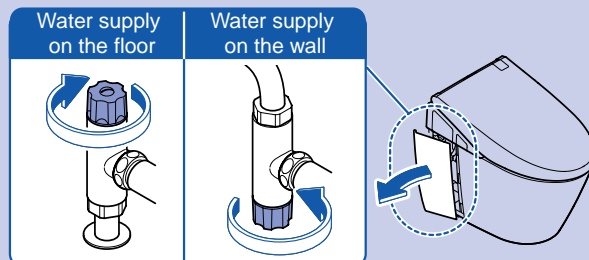

Check the following before having the product repaired.

Check the following first

Check the light on the top unit display

- Is the POWER light on?

[See page 15](#)

If the POWER light is on

[Go to the "Check this on the remote control" section below.](#)

- When the power plug is inserted in the outlet, the soft light will flash for somewhere between 10 seconds to a minute. During this period, the seat sensor A is initializing. The auto lid open/close feature will not function until the sensor is done initializing, but the lid and seat can still be operated using the remote control.

If the POWER light is not on

- Are other lights besides the POWER light?
 - If the ENERGY SAVER light is on, the energy saver is activated. [See Page 30](#)
 - If other lights are off and the POWER light is flashing, the product is in antifreeze mode. [See Page 47](#)
- Are all the lights off?
 - Check if the following steps cause the POWER light to come on

① Push the on/off button on the top unit control area.

② Check if the power has failed or the breaker is opened. If so, wait until power is available or close the breaker.

Confirm this!

Top unit display

Light is on

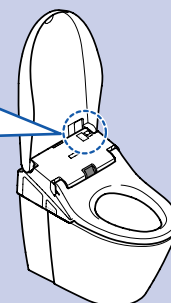
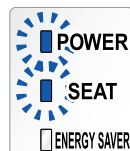



Check this on the remote control

- Is the LCD display on the remote control completely off?
 - Then check if the batteries are installed properly.
- Is  shown on the remote control display?
 - The batteries are dead, please replace them. [See Page 13](#)
- Check if the signal emitting area on the remote and the signal receiving area on the top unit are covered, dirty or wet.
 - Remove the obstacles or clean the signal emitting area. [See Page 12](#)



When all the above has been checked, go to the "Checking problems" section on the next page.

Checking Problems

Cleansing and drying				
Problem	Check	Result (cause)	Solution	
Rear cleansing, front cleansing and warm air drying will not activate with the remote control	Will the front and rear cleansing buttons on the top unit activate the their respective features?	【Yes】 The top unit can not receive the signal.	Check the steps in the “Check this on the remote control” section. Page 50	
	Caution If the seat sensor does not detect a person, the cleansing and drying features are unavailable. Please sit on the NEOREST to confirm this is not cause of the problem.	【No】	The seat sensor A does not work. Check if the seat sensor A is obstructed, dirty or wet. Make sure the seat sensor is unobstructed, clean and dry. Page 10,17	
	Does the wand extend when one of the cleansing buttons is pushed on the remote control?		【Water does not flow or spray is very weak.】 No water is being supplied to the NEOREST.	Has the water supply stopped? Push  and wait till water supply is resumed. Is the water shutoff valve closed? Try opening the main valve and the water shutoff valve. Page 11,15 Is the water supply filter clogged? Please clean the water supply filter. Page 43
			【It does not extend】 Safety devices are activated when the sensor continuously detects a person.	When a person has sat on the toilet seat for 2 hours, the cleansing and drying features are deactivated. For safety reasons, please leave the seat and use it again later. If seat sensor A is obstructed, dirty or wet, it may continuously detect a “person.” Make sure the seat sensor is unobstructed, clean and dry. Page 10, 17 Seat sensor A will keep detecting a “person” if it is covered by an obstacle. Please remove the obstacle.

Flushing			
Problem	Check	Result (cause)	Solution
No flush	Does the NEOREST flush if the flush buttons on the remote control or the top unit are pushed?	【No】 The water supply is cut off.	Has the tap water failed? Wait till the water supply resumes. Flush the toilet bowl with a bucket of water. Page 46 Is the water shutoff valve closed? Open it completely. Page 15
	Do you push the switch continually?	-	The bowl must be refilled before another flush can proceed. This takes about 6 seconds.
Auto flush is unavailable	Push  Does the remote control display change to 【ON/OFF】 ?	【Displays 【ON/OFF】】	If seat sensor A is obstructed, dirty or wet, it may continuously detect a “person.” Make sure the seat sensor is unobstructed, clean and dry. Page 10, 17
			Auto flush is unavailable for the next 60s after an auto flush is executed. You can use the remote control to flush during those 60 seconds. A person must stand in front of or sit on the Neorest at least 6 seconds for the auto flush to be activated. Page 27
			Confirm seat sensor A can detect a person normally. Page 17, 26
			Auto flush will not execute a person standing in front of the NEOREST steps away for less than 3 to 5 second. Page 27 Confirm seat sensor A is not continuously detecting a “person”. Page 17, 26

Flushing (continued)

Problem	Check	Result (cause)	Solution
Auto flush is unavailable	Push AUTO  . Does the remote control display change to [ON OFF] ?	<p>【Displays [ON OFF]】</p> <p>The auto flush feature has been set to off</p>	<p>Push AUTO  again to set auto flush to ON.</p> <p style="text-align: right;">Page 28, 29</p>

Seat and lid open/close

Problem	Check	Result (cause)	Solution
Seat and lid fail to open/close	Can you open/close the seat and lid with the remote control?	<p>【No】</p> <p>The seat and lid are not properly installed.</p>	<p>Install the seat and lid properly.</p> <p style="text-align: right;">Page 37</p>
		<p>【No】</p> <p>The signal from the remote control is not being received.</p>	<p>Check the steps in the “Check this on the remote control” section..</p> <p style="text-align: right;">Page 50</p>
Lid auto open fails	Push AUTO  . Does the remote control display change to [ON OFF] ?	<p>【Displays [ON OFF]】</p> <p>Auto open/close is set to ON.</p>	<p>Seat sensor B may not detect a person when it is obstructed, dirty or wet. Make sure the seat sensor is unobstructed, clean and dry.</p> <p style="text-align: right;">Page 26</p> <p>The toilet bowl lid will not open automatically for the next 2 seconds after it has been closed manually.</p> <p>When the room temperature is over 86°F (30°C), the sensor can not detect the person because the temperature difference is too small. If this is the case, use the remote control. Push  on the remote control.</p>
		<p>【Displays [ON OFF]】</p> <p>Auto open/close is set to OFF.</p>	<p>Push AUTO  again on the remote control to turn the auto open/close feature ON.</p> <p style="text-align: right;">Page 25</p>
	Is the soft light flashing?	<p>【Yes】</p>	<p>When the power plug is inserted in the outlet, the soft light will flash for somewhere between 10 seconds to a minute. During this period, the seat sensor A is initializing. The auto lid open/close feature will not function until the sensor is done initializing, but the lid and seat can still be operated using the remote control. Push  on the remote control.</p>
Seat and lid auto close failed	Push AUTO  . Does the remote control display change to [ON OFF] ?	<p>【Displays [ON OFF]】</p> <p>Auto open/close is set to ON.</p>	<p>If a person has been within 1ft. (30cm) of the NEOREST for more than 6 seconds and then moves away, the seat and lid will automatically close 90 seconds later. If a person continues to stay within 1ft. (30cm) of the NEOREST, the lid will not close automatically.</p> <p style="text-align: right;">Page 23</p>
		<p>【Displays [ON OFF]】</p> <p>Auto open/close is set to OFF.</p>	<p>If the seat sensor A is obstructed, dirty or wet, it may continuously detect a “person.” Make sure the seat sensor is unobstructed, clean and dry.</p> <p style="text-align: right;">Page 17, 26</p>
		<p>【Displays [ON OFF]】</p> <p>Auto open/close is set to OFF.</p>	<p>Push AUTO  again on the remote control to turn the auto open/close feature ON.</p> <p style="text-align: right;">Page 25</p>



Deodorizer, energy saver

Problem	Check	Result (cause)	Solution
Deodorizer does not work	Can the deodorizer be heard when the seat sensor detects someone sitting on the NEOREST?	<p>【No】</p>	<p>Check if seat sensor A is having trouble detecting whether or not a person is seated on the NEOREST.</p> <p style="text-align: right;">Page 17</p>
		<p>Is seat sensor A covered with dirt or water? Remove dirt from the sensor</p> <p style="text-align: right;">Page 10, 17</p>	

Deodorizer, energy saver (continued)

Problem	Check	Result (cause)	Solution
Deodorizer does not work	Can the deodorizer be heard when the seat sensor detects someone sitting on the NEOREST?	[No]	Seat sensor A may not detect a person because of the way they are seated, their clothing color or clothing material. Sit further back on the seat or lift your clothing to expose skin to the sensor.
		The deodorizer feature is set to OFF	Turn the deodorizer feature ON. Page 20
		The deodorizer filter is clogged	Clean the deodorizing filter. Page 40
Timer saver or auto saver does not work	Have the remote control batteries recently been replaced?	The setting is reset when the batteries are replaced or taken out.	Please set timer saver or auto saver again. Page 31 - 34
Auto saver does not work	Push  . Is AUTO ENERGY SAVER IS ON shown in the remote control display?	The auto saver is set to ON.	Even if the auto energy saver is on it still needs to learn usage pattern. Page 30

Seat, water, dryer temperatures

Problem	Check	Result (cause)	Solution
Seat does not warm up (cold)	What does the remote control display indicate?	The seat temperature set to OFF or to a low value.	Push  on the remote control to adjust. Page 18
	Is the ENERGY SAVER light on the top unit turned on?	[Yes] When the timer saver is on seat heater is off to conserve energy.	When a person sits on the seat, it takes about 15min to heat the seat back up to the desired temperature. See Page 31 for timer saver
		[Yes] When an auto saver is on seat temperature is lowered to conserve energy.	When a person sits on the seat, the seat will be heated back up to the desired temperature in a short time. See Page 32 for auto saver
	Has a person sat on the NEOREST seat for over 1hr?	[Yes] When the sensor detects a person, a safety feature is activated and the seat heater is turned OFF.	Leave the seat and it will be heated back up to the desired temperature in a short time.
	Is the seat sensor dirty?	[Yes]	If the seat sensor A is obstructed, dirty or wet, it may continuously detect a "person." Make sure the seat sensor is unobstructed, clean and dry. Page 17
Water for front and rear cleansing is cold	What does the remote control display indicate?	The water temperature set to OFF or to a low value.	Push  on the remote control to adjust. Page 18
	Is the water only cold when the cleansing starts?	-	When the water supply temperature is very cold, the cleansing water temperature will be cold when cleansing begins.
The air from the dryer is cold	What does the remote control display indicate?	The dryer temperature set to a low value.	Push  on the remote control to adjust. Page 19





The cleansing pressure is too low

Problem	Check	Result (cause)	Solution
Cleansing water is weak	What does the remote control display indicate?	The pressure set to a low value.	Push  on the remote control to adjust. Page 16
	Is the water supply filter blocked?	-	Clean the water supply filter. Page 43
	Is the water shutoff valve closed or partially closed?	-	Completely open the water shutoff valve to get strong spray. Page 11, 15



Unexpected action - cleansing and dryer features

Problem	Check	Result (cause)	Solution
Water cleansing and/or warm air stops during operation	Does the feature work properly during the next use?	The cleansings features will stop automatically in 5 minutes, warm air drying 10 minutes.	To use it again, push the appropriate button.
	Is the seat sensor having difficulty detecting a person on the seat?	–	When a person lifts thier body or bends down while using the toilet bowl, the sensor may not detect them. Sit properly on the NEOREST.
Water randomly runs out of the wand nozzle	Is the seat sensor dirty, wet or obstructed?	When a person sits down, water will flow out of the wand for several seconds to clear out any cold water.	If the seat sensor A is dirty or wet, it may continuously detect a “person” and cause water to runs out of the wand. Make sure the seat sensor is clean and dry.
	Is the POWER light flashing?	[Yes] Antifreeze function is set to ON.	If the antifreeze mode is set to ON, water will flow out of the wand every 5 minutes. If the antifreeze mode is unnecessary, please turn it OFF. Page 47, 48
	Is it part of normal function?	Water runs out of the nozzle for about 30 seconds after someone gets up from the NEOREST, then it retracts. After that warm air cover will open and close.	Water runs out of the wand for about 30 seconds after someone gets up from the NEOREST, then it retracts. After that warm air cover will open and close.

Unexpected action - Seat and lid open/close

Problem	Check	Result (cause)	Solution
Lid opens unexpectedly	Push   . Does the remote control display change to [ON OFF] ?	[Displays [ON OFF]] Auto open/close is set to ON.	If the remote control batteries are replaced, the auto open/close feature returns to it's default setting of ON. Set the auto open/close feature to the user's preference. Page 25, 26
	–	When sensor B is exposed to sun, it may function improperly.	Keep the NEOREST away from sunlight.
	Is the bathroom furnished with a heater?	[Yes] If the heater is within the detection range of sensor B, it may cause the sensor function improperly.	Keep the bathroom heater out of the detection range of sensor B.
	Is the bathroom door open?	When the bathroom door is open, the sensor may detect a person passing by.	Keep the bathroom door closed.
Lid closes unexpectedly	Push   . Does the remote control display change to [ON OFF] ?	[Displays [ON OFF]] Auto open/close is set to ON. If it is difficult for seat sensor B to detect a person, then the lid may close even if a person has approached the NEOREST.	Seat sensor B may not detect a person when it is obstructed, dirty or wet. Make sure the seat sensor is unobstructed, clean and dry. Page 10, 17, 26
			The seat sensor A may not detect a person because of the way they are seated, their clothing color or alothing material. Sit futher back on the seat or lift you clothing to expose skin to the sensor.

Unexpected action - Auto Flushing

Problem	Check	Result (cause)	Solution
Auto flushing is occurring at odd times	Push   . Does the remote control display change to [ON OFF] ?	[Displays [ON OFF]] If it is difficult for seat sensor A to detect a person, the auto flush may activate while the NEOREST is in use.	When a person lifts thier body or bends down while using the toilet bowl, the sensor may not detect them. Sit properly on the NEOREST. The seat sensor A may not detect a person because of the way they are seated, their clothing color or alothing material. Sit futher back on the seat or lift you clothing to expose skin to the sensor. Page 17
		[Displays [ON OFF]] The remote control batteries have been replaced recently.	Auto flush returns to its default setting of ON when the batteries are replaced or taken out. Set the auto flush to OFF if it is the user's preference Page 28,29
Auto flushing occurs before its supposed to	Is POWER light on?	[Flashing] Antifreeze function is set to ON	If the antifreeze mode is set to ON, the NEOREST will automatically flush every 10 minutes. If the antifreeze mode is unnecessary, please turn it OFF. Page 47, 48

Other problems

Problem	Check	Result (cause)	Solution
Weak flush	Is the flush weak?	Is the water shutoff valve closed?	Open the water shutoff valve completely. Page 15
		Is the water supply filter blocked?	Clean the water supply filter Page 43, 44
		When using water in other places, does the water pressure drop?	Stop using water in other places (such as sinks or showers), then try flushing the NEOREST again.
The flush is not clearing the bowl.	-	The water supply to the NEOREST is inadequate.	Open the water shutoff valve completely. Page 15
			Water supply filter is blocked. Clean the water supply filter. Page 43, 44
The pipe connector has a leak	Is the connection loose?	-	Fasten the nut with a monkey wrench. If the problem still exists, close the water shutoff valve and repair it.
There is a noise when someone takes a seat on the NEOREST	Is it part of normal function?	[Yes]	When a person sits down, water will flow out of the nozzle for several seconds to clear out any cold water. Page 16
Soft light will not come on	Is the soft light set to OFF?	[Yes]	Enable the soft light to ON. Page 22, 23
The dryer cover will not be close	-	If the cover has been opened manually, it will not close by itself.	Detach and re-insert the power plug.

Specifications

Item			Contents	
Power supply			AC120V 60Hz	
Power usage			1284W	
Average Power Consumption per hour *1			21Wh	
Cord length			3.2 ft. (1.0m)	
TOILET BOWL	Flush volume		Full 1.6 gal (6L) Light 1.05gal (4L)	
	Water supply system		Direct connection to city water tap	
	Flush type		"Cyclone" (Siphon type)	
	Bowl style		Elongated	
Antifreeze	Flushing system	Flushing vol.	10.6 gal/h (40L/h)	
NEOREST	Cleansing	Spraying volume	Rear	About 0.07~0.11gal/min(0.27~0.43L/min) @29 PSI (0.2MPa)
			Soft	About 0.07~0.11gal/min(0.27~0.43L/min) @29 PSI (0.2MPa)
			Front	About 0.08~0.11gal/min(0.29~0.43L/min) @29 PSI (0.2MPa)
		Water temperature		Range approximately 86°~104°F (30°~40°C)
		Heater Power consumption		1200W (instant)
		Safety		Temp fuse, Overheat breaker (auto recovery bimetal) · non-load proof float switch
	Warm air	Temperature *2		Range about 104°~138°F (40°~59°C)
		Volume		10.6 ft ³ /min (0.30m ³ /min)
		Capacity		350W
	Heater	Safety		Temp fuse
Surface temperature		Range approx. 82~97°F (28~36°C) approx. auto saver 79°F (26°C)		
Heater Capacity		50W		
			Temp fuse	
Water supply pressure			Min 10PSI (0.07MPa) flowing @ 5.3gal/min (20L/min) Max 108PSI (0.75MPa) static	
Water supply temperature			32°~95°F (0~35°C)	
Ambient temperature			32°~104°F (0~40°C)	
Size			W 1.3ft. (389mm) L 2.1ft. (655mm) H 1.8ft. (542mm)	
Weight			82.7lb (37.5kg) -- Top unit 16.3lb (7.5kg), Bowl 66.1lb (30kg)	

*1 Measuring conditions: The figures shown above are the result of calculation in term of the annual average energy saving mode, 4 persons family (2M, 2F), 12 uses per day, @ room temperature 59°F (15°C) water temperature 59°F (15°C). As for timer saver, the average time of use set by timer in a family is calculated in terms of usage rate.

*2 Temperature at our measuring point near the warm air outlet

Replacing the deodorizer cartridge

If there is still an odor after you have cleaned the deodorizer filter, replace the deodorizer cartridge

Replace

1: Remove the deodorizer cartridge

1 Remove the cover on the right of the top unit

- ⊖ Be careful to not leave any scratch when using a flat screwdriver.

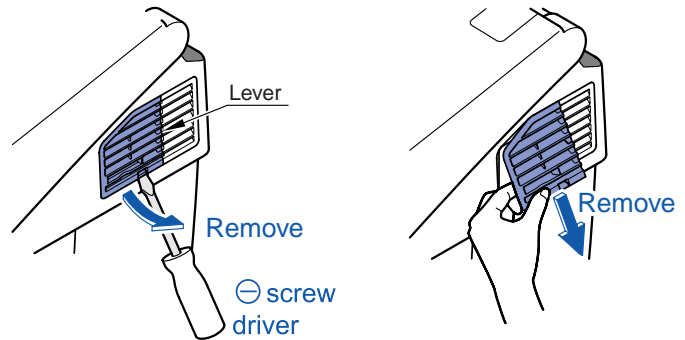

2 Hold the deodorizer cartridge by its flap and pull it out

- If black powder from the deodorizer cartridge, gets on your hand, wash your hand immediately.
- It may cause skin or eye irritation.

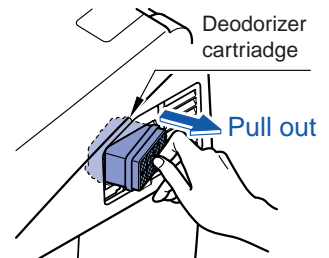

2: Install the deodorizer cartridge

1 Install the new deodorizer cartridge

Install it in the reverse order of previous instructions

- Insert the cartridge firmly in its original place.
- Please don't remove the antibacterial filter.

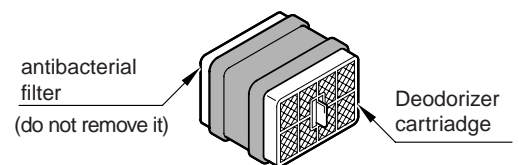

2 Install the cover

- 1 Insert the the cover flap into its slot on the top unit
 - 2 Push the cover till you hear a CLICK sound
- Push in the 2 places shown to install the cover.
 - Confirm that the cover is flush with out from the top unit.

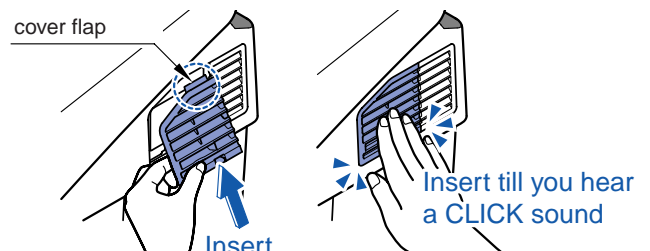

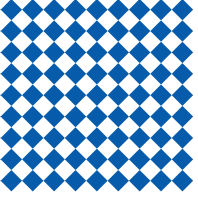

Limited Warranty

Three Year Limited Warranty.

1. TOTO® warrants its Neorest® brand product ("Product") to be free from defects in materials and workmanship during normal use when properly installed and serviced, for a period of three (3) years from date of purchase. This limited warranty is extended only to the ORIGINAL PURCHASER of the Product and is not transferable to any third party, including but not limited to any subsequent purchaser or owner of the Product. This warranty applies only to TOTO Product purchased and installed in North, Central and South America.
2. TOTO's obligations under this warranty are limited to repair, replacement or other appropriate adjustment, at TOTO's option, of the Product or parts found to be defective in normal use, provided that such Product was properly installed, used and serviced in accordance with instructions. TOTO reserves the right to make such inspections as may be necessary in order to determine the cause of the defect. TOTO will not charge for labor or parts in connection with warranty repairs or replacements. TOTO is not responsible for the cost of removal, return and/or reinstallation of the Product.
3. This warranty does not apply to the following items:
 - a) Damage or loss sustained in a natural calamity such as fire, earthquake, flood, thunder, electrical storm, etc.
 - b) Damage or loss resulting from any accident, unreasonable use, misuse, abuse, negligence, or improper care, cleaning, or maintenance of the Product.
 - c) Damage or loss resulting from sediments or foreign matter contained in a water system.
 - d) Damage or loss resulting from improper installation or from installation of the Product in a harsh and/or hazardous environment, or improper removal, repair or modification of the Product. This includes locations where the water pressure is above local codes or standards. (NOTE: Product model codes allow a maximum of 80 PSI. Check local codes or standards for requirements).
 - e) Damage or loss resulting from electrical surges or lightning strikes or other acts which are not the fault of TOTO or which the Product is not specified to tolerate.
 - f) Damage or loss resulting from normal and customary wear and tear, such as gloss reduction, scratching or fading over time due to use, cleaning practices or water or atmospheric conditions, including but not limited to, the use of bleach, alkali, acid cleaners, dry (powder) cleaners or any other abrasive cleaners or the use of metal or nylon scrubbers.
4. If the Danger Label which has been placed over the seams on the back of the Product's top unit is broken or otherwise not intact, this limited warranty is void.
5. In order for this limited warranty to be valid, proof of purchase is required. TOTO encourages warranty registration upon purchase to create a record of Product ownership at <http://www.totousa.com>. Product registration is completely voluntary and failure to register will not diminish your limited warranty rights.
6. If the Product is used commercially or is installed outside of North, Central or South America, TOTO warrants the Product to be free from defects in materials and workmanship during normal use for one (1) year from the date of installation of the Product, and all other terms of this warranty shall be applicable except the duration of the warranty
7. THIS WARRANTY GIVES YOU SPECIFIC LEGAL RIGHTS. YOU MAY HAVE OTHER RIGHTS WHICH VARY FROM STATE TO STATE, PROVINCE TO PROVINCE OR COUNTRY TO COUNTRY.
8. To obtain warranty repair service under this warranty, you must take the Product or deliver it prepaid to a TOTO service facility together with proof of purchase (original sales receipt) and a letter stating the problem, or contact a TOTO distributor or products service contractor, or write directly to TOTO U.S.A., INC., 1155 Southern Road, Morrow, GA 30260 (888) 295 8134 or (678) 466-1300, if outside the U.S.A. If, because of the size of the Product or nature of the defect, the Product cannot be returned to TOTO, receipt by TOTO of written notice of the defect together with proof of purchase (original sales receipt) shall constitute delivery. In such case, TOTO may choose to repair the Product at the purchaser's location or pay to transport the Product to a service facility.

WARNING! TOTO shall not be responsible or liable for any failure of, or damage to, this Product caused by either chloramines in the treatment of public water supply or cleaners containing chlorine (calcium hypochlorite). NOTE: The use of a high concentrate chlorine or chlorine related products can seriously damage the fittings. This damage can cause leakage and serious property damage.

THIS WRITTEN WARRANTY IS THE ONLY WARRANTY MADE BY TOTO. REPAIR, REPLACEMENT OR OTHER APPROPRIATE ADJUSTMENT AS PROVIDED UNDER THIS WARRANTY SHALL BE THE EXCLUSIVE REMEDY AVAILABLE TO THE ORIGINAL PURCHASER. TOTO SHALL NOT BE RESPONSIBLE FOR LOSS OF THE PRODUCT OR FOR OTHER INCIDENTAL, SPECIAL OR CONSEQUENTIAL DAMAGES OR EXPENSES INCURRED BY THE ORIGINAL PURCHASER, OR FOR LABOR OR OTHER COSTS DUE TO INSTALLATION OR REMOVAL, OR COSTS OF REPAIRS BY OTHERS, OR FOR ANY OTHER EXPENSE NOT SPECIFICALLY STATED ABOVE. IN NO EVENT WILL TOTO'S RESPONSIBILITY EXCEED THE PURCHASE PRICE OF THE PRODUCT. EXCEPT TO THE EXTENT PROHIBITED BY APPLICABLE LAW, ANY IMPLIED WARRANTIES, INCLUDING THAT OF MERCHANTABILITY OR FITNESS FOR USE OR FOR A PARTICULAR PURPOSE, ARE EXPRESSLY DISCLAIMED. SOME STATES DO NOT ALLOW LIMITATIONS ON HOW LONG AN IMPLIED WARRANTY LASTS, OR THE EXCLUSION OR LIMITATION OF INCIDENTAL OR CONSEQUENTIAL DAMAGES, SO THE ABOVE LIMITATION AND EXCLUSION MAY NOT APPLY TO YOU.

Notes

Notes

TOTO

1155 Southern Road
Morrow, GA 30260
(770) 282 8686

For your safety, be sure to inspect your NEOREST 550 occasionally.

- Is the power plug abnormally hot?
- Is the power plug covered with dust?
- Is the outlet loose?
- Is your NEOREST 550 operating differently than usual?

* In case anything is abnormal, contact TOTO USA to prevent a fire or an electrical shock.