

INSTALLATION INSTRUCTIONS

Swiss Madison[®]
well made forever

Touchless Flush Technology

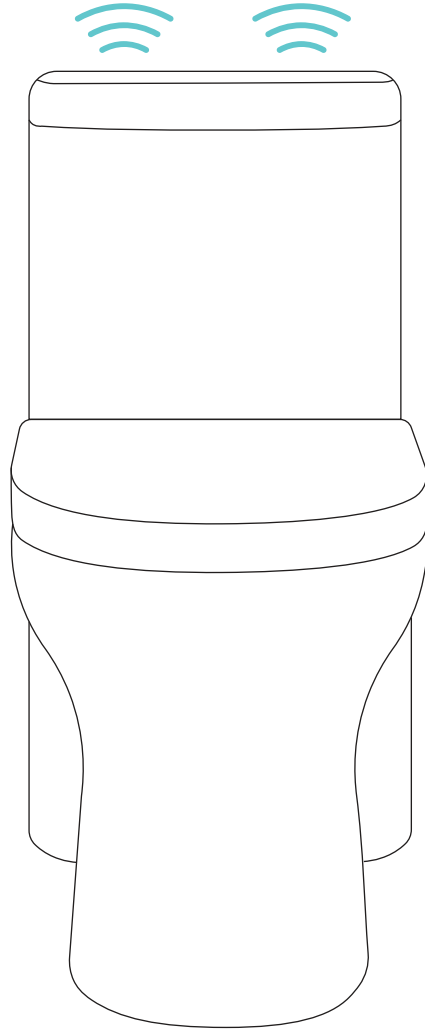

Share your pictures for a feature!
using **#SwissMadison**





Prior to Installation:

- Inspect toilet to ensure no damages have occurred while in shipping.
- Observe all plumbing and building codes in accordance with your state and local requirements.
- Remove old toilet.
- Make sure mounting surface is CLEAN and LEVEL.
- All dimensions are nominal! Be sure to measure your toilet prior to installation.

General Recommendations: Read installation and maintenance instructions thoroughly before installing the toilet. Be sure to use proper tools and always wear proper personal safety accessories for your protection.

If you have any questions or concerns please contact us:

1-434-623-4766

info@swissmadison.com

Thank you for your purchase!

Thank you for purchasing a Swiss Madison Touchless Flush Toilet.

We appreciate your business and know you will enjoy your toilet for many years to come.

If you have any questions or require assistance we would be happy to help,
please contact us at 1-434-6234766 or info@swissmadison.com.

To learn more about our products, please visit:

www.swissmadison.com

Sincerely,

The Swiss Madison Team

PARTS LIST:

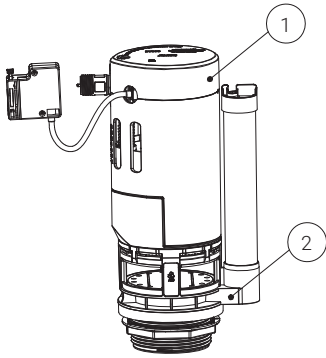

1. Flush Valve
2. Base



3. Hose Set

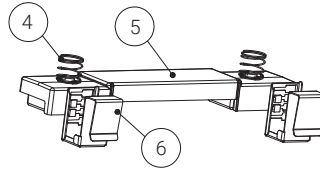

4. Compressed spring (2)
5. Sensor module
6. Mounting bracket

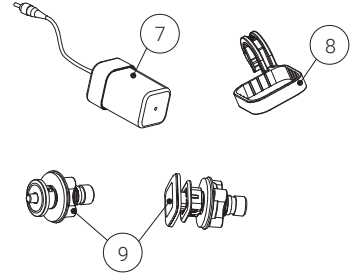

7. Battery box
8. Battery box holder
9. Dual Push-button

USAGE INSTRUCTIONS:

Touchless Flush: Wave-sensing within 30 mm directly above the flush button (full flush or half flush).

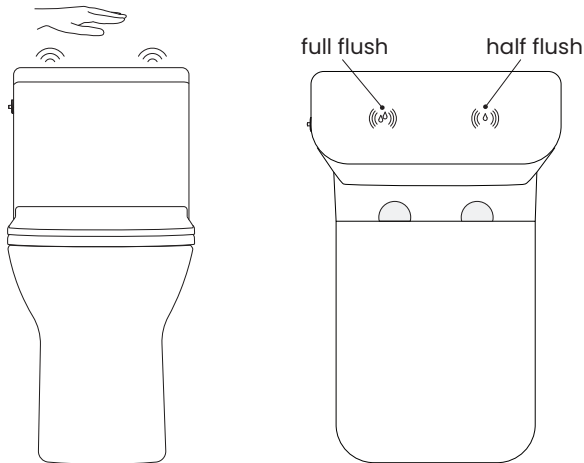

Mechanical Push Button Flush: To use if the battery is low or electronically faulty.

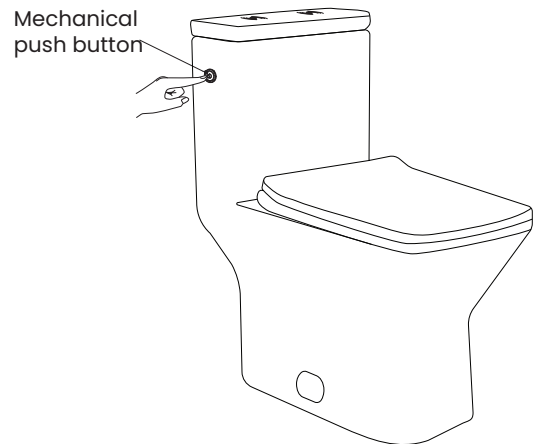

NOTE: If there is suddenly foreign matter on the lid of the water tank, the product comes with an adaptive function, and it will wait for 30 seconds to resume normal use.

NOTE: Specialized tools may be necessary to install, plumbing not included.

The step-by-step guidelines in the installation instructions are a general reference.
Should there be any discrepancies, Swiss Madison cannot be held liable.
It is recommended to install all Swiss Madison products by hiring a licensed professional

- i**
1. Please read the installation instructions carefully and follow the steps to install them step by step to avoid damage to the product or damage caused by bad operation.
 2. Please do not use parts not supplied by the company, such as glass glue, for the installation of our accessories.
 3. Please remove the old parts and clean the water tank before installing this accessory. There may be a lot of debris for newly renovated pipes. Please clean up before installing the water tank parts.

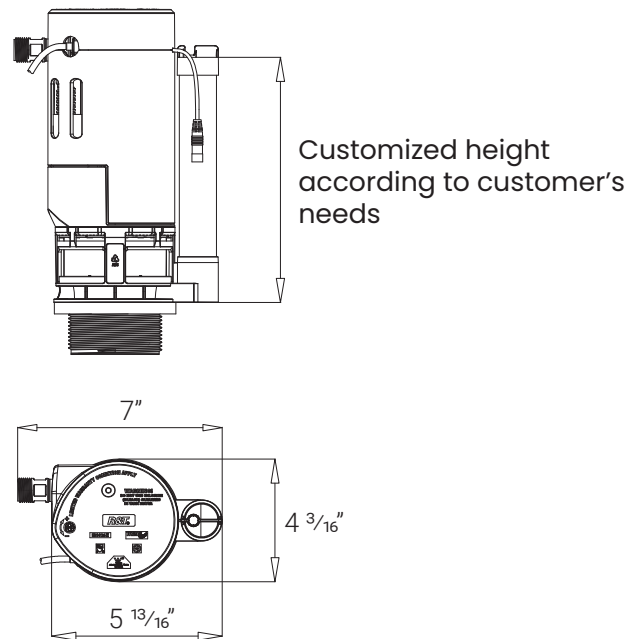
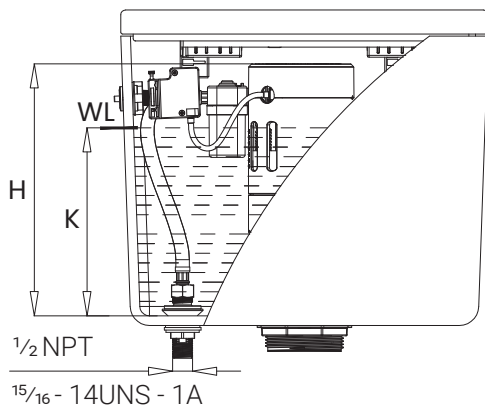

H: adjustable height: 10 5/16" - 12 3/16"

K: adjustable height: 6 1/2" - 9 13/16"

NOTE: Adjustments include the height of the 8mm rubber gasket.

NOTE: Drawings may not exactly define contour of china.

Battery Box and Sensor Module Installation

1. Install Battery Box Holder

- Install the battery box holder on the water inlet joint.

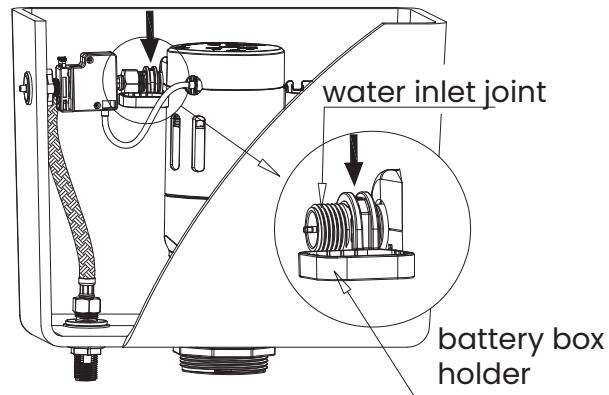

2. Install Battery

- Insert the battery (4 x 1.5V (AA) size alkaline batteries) into the battery box. When the lid is buckled, squeeze the side of the rubber plug with your fingers to discharge the air inside the box to ensure the sealing effect.

NOTE: Batteries not included.

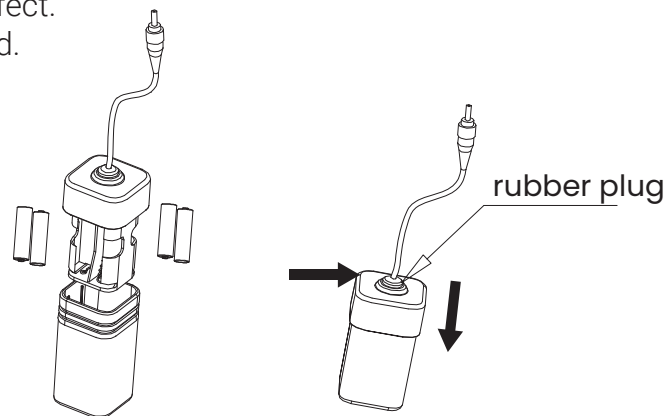

3. Install Battery Box

- Install the battery box into the holder.

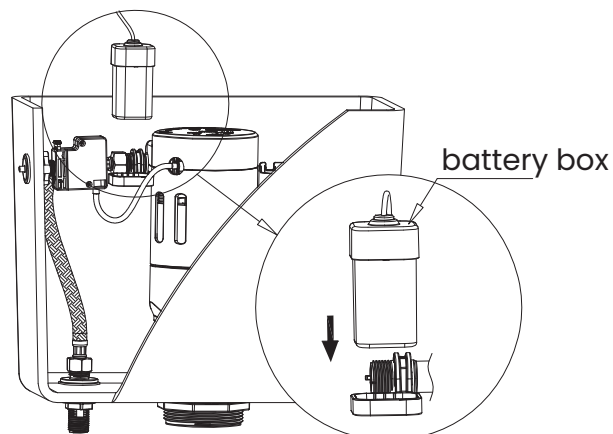

4. Install Springs

- Install the two springs on the two buckles of the sensor module.
- The mounting bracket attaches to both sides of the module.

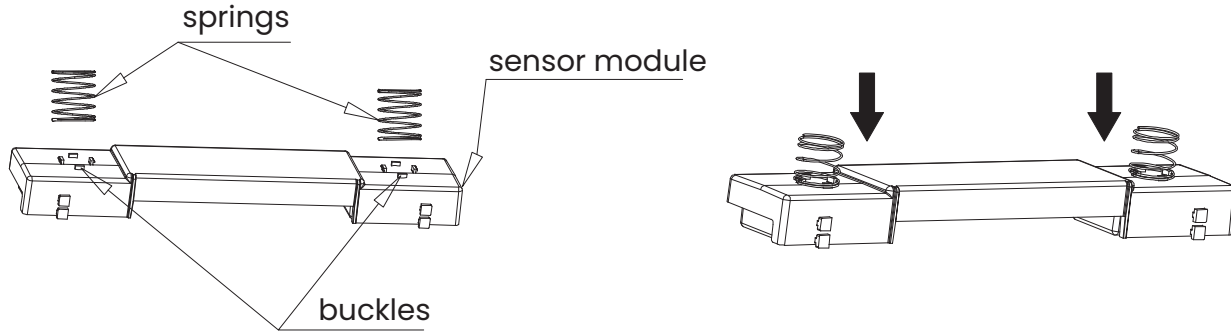

5. Install Mounting Brackets

- Install the two mounting brackets on the two side buckles of the sensor module.
- NOTE:** The mounting bracket has four sims. Please select the sim position as needed. When selecting the sim position, ensure that the lid is attached to the modular spring and the distance from the top of the sensor module is less than 15mm.

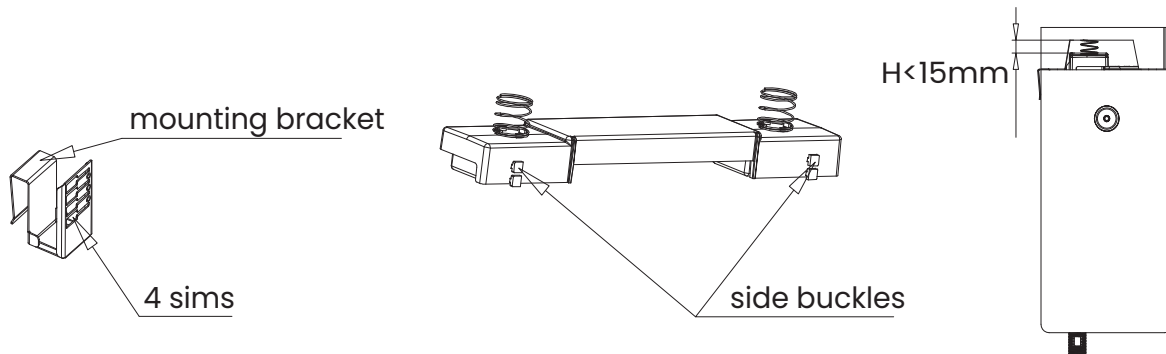

6. Hang Sensor Modules

- Hang the sensor module sets on the rear tank wall.

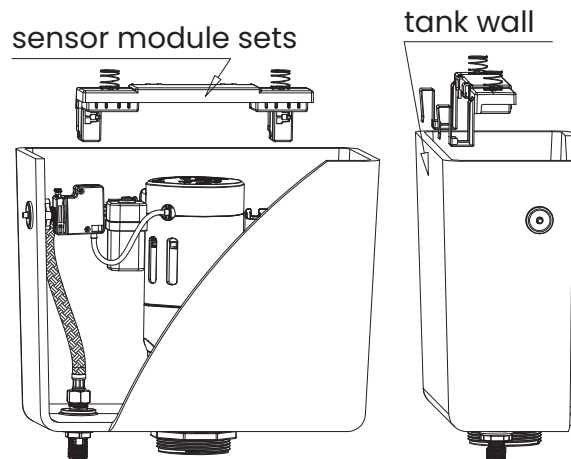

7. Connect to Battery Box

- Plug the DC connector on the battery box, valve body and sensor module (spin while inserting).
- Connect the sensor module to the valve body, then connect the sensor module to the battery box.
NOTE: When the DC connector is connected, red to red, black to black.

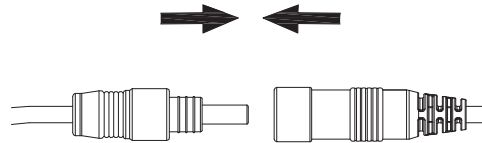

8. Connect Water Supply

- Screw on the water supply pipe and turn on the water supply valve.

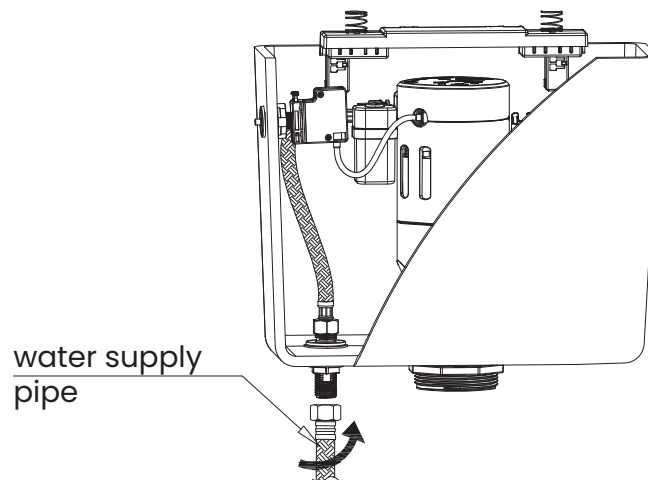

9. Place Tank Lid Sticker

- Place sticker on the outer surface of the tank lid, directly above the module sensing area.

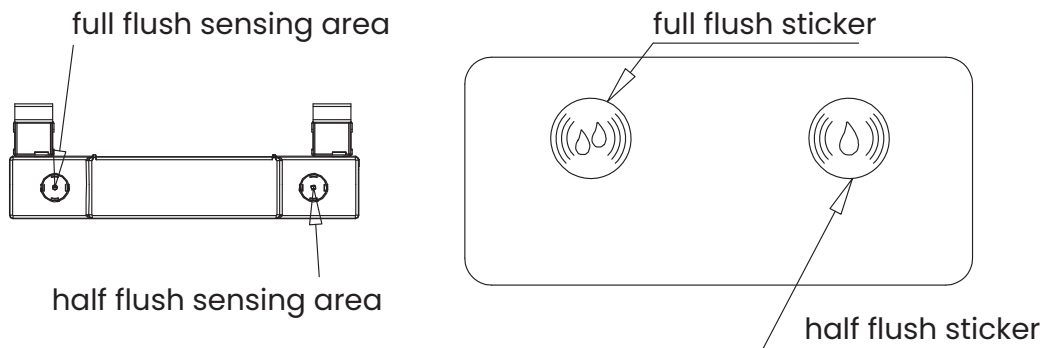

Major Water Level Adjustment

1. Scale the Water Level

- Press the buckle with one hand and pull or press the water inlet fixed cover at the same time.
- Release the buckle when the water inlet cover is adjusted to the appropriate scale.

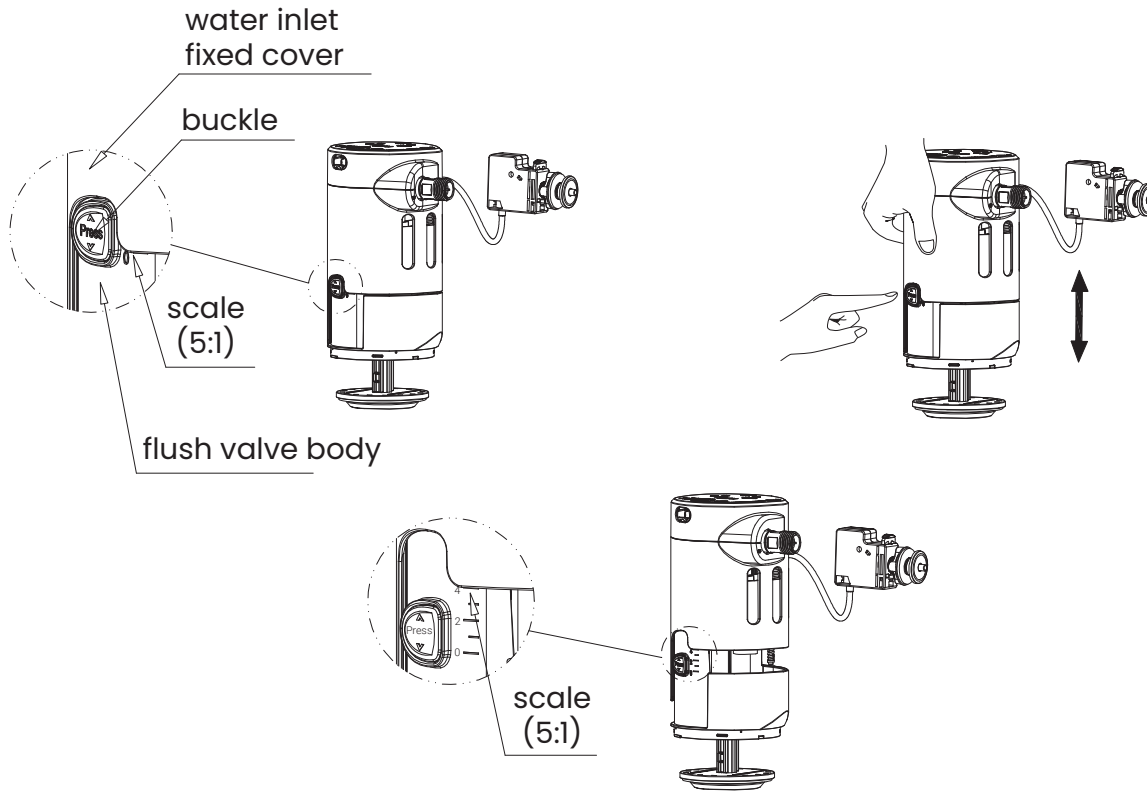

Minor Water Level Adjustment

1. Lower Water Level

- Turn the rod counter clockwise (in the direction of the "-") with a flat or cross slot screwdriver to lower the shut-off cup to the desired position.

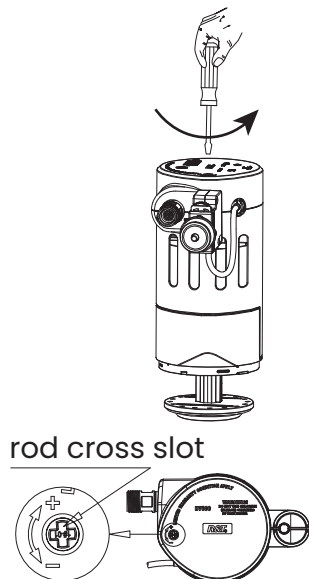

2. Raise Water Level

- Turn the rod clockwise (in the direction of the "+") with a flat or cross slot screwdriver to raise the shut-off cup to the desired position.

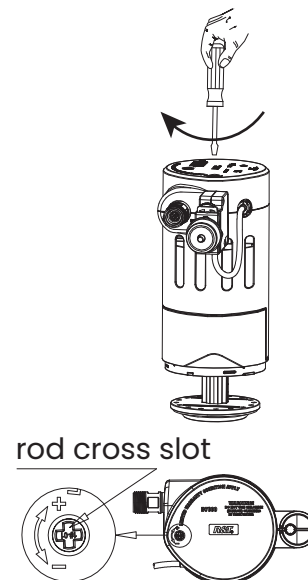

Daily Maintenance & Usage Caution

1. Daily Usage Caution

- Do not place items or do irrelevant actions in the sensing area to avoid false induction.
- Please do not use corrosive solvents or any related chemical ingredients in the water tank. Solvents containing chlorine or hypochlorite will seriously damage the tank fittings, resulting in water leakage.
- Do not get close to high-power electronic devices, they may affect the use of the product.
- Do not let the DC plug touch the water when disassembling or cleaning the product. If you accidentally touch the water, please dry it to avoid the electronic components burning out.
- It is recommend to check the filter regularly for blockage. If it is clogged, please clean the filter to avoid affecting normal use.
- If the battery is low, please replace the battery to avoid affecting normal use.

2. Cleaning Filter

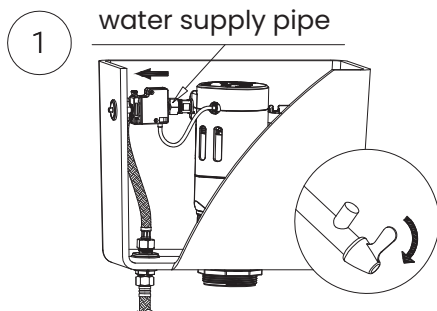

Shut off the water supply valve, then remove the water supply pipe.

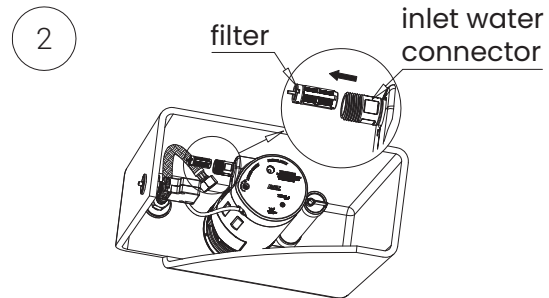

Remove the filter screen from the inlet water connector.

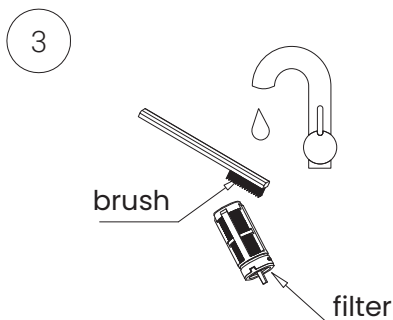

Clean the filter screen with water.

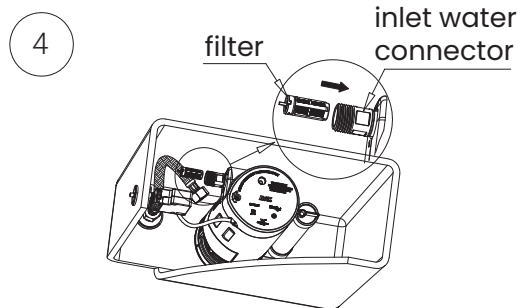

Re-install clean filter back into water connector.

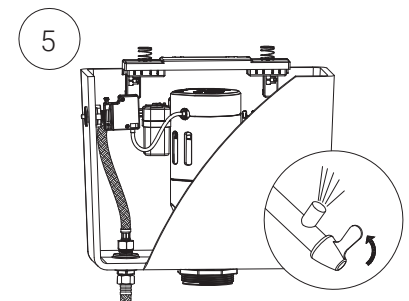

Insert the water supply pipe back to the water connector and turn on the water supply valve.

3. Low voltage battery determination and replacement

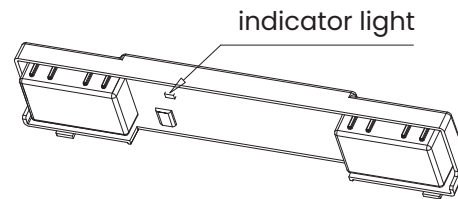

- During the use of this product, if the flush does not work after wave sensing, and the indicator light on the sensor module (at the bottom of the module) flashes 12 times continuously, indicating that the battery is low voltage and needs to be replaced.

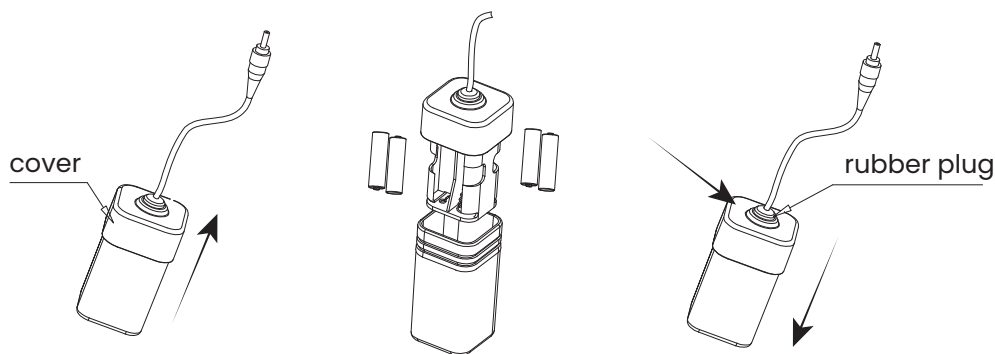

- Pull out the cover, remove the used battery and put the new battery into the battery box. When the cover is buckled, squeeze the side of the rubber plug with your fingers to discharge the air inside the box to ensure the sealing effect.

NOTE: Battery must be 1.5 V (AA) alkaline battery. Do not mix different brands of battery or old and new batteries. Battery life will be significantly reduced when using non-alkaline batteries.

Product Features:

- Integrated Design: Integrated design combines fill valve and flush valve, easy installation, with a concise and aesthetic appearance.
- Touchless Flush: No-touch induction flush, flush by waving your hand, can prevent bacterial infection, easy to use.
- Back-Up Mechanical Push Button: Mechanical push buttons can be used when the battery is dead or faulty and unusable.
- Energy Saving: Low power consumption: 4 x 1.5 V "AA" size alkaline batteries can be used for 8-10 months if using 3000 cycles per month (based on laboratory data, results differ in actual environment).
- Water Saving: Patented, delayed filling design to lower water consumption.
- Wide Water Pressure Application Range: Can work normally under the dynamic pressure of 0.07Mpa to the static pressure of 0.8Mpa with stable water consumption.
- Convenient Water Level Adjustment: Adjustable valve body and shut-off cup height to adjust water level, applicable for a wide range of different tanks.
- Anti-Siphon Function: Keeps water from returning to the water supply system and prevents contamination.
- Fast Drainage and Strong Flushing Effect: With a 3-inch base, the draining speed is about 4 L/S in a 0.7 L/cm standard water tank.
- Stable and Reliable: Advanced production technology seals the control circuit. The plug-in adopts waterproof connectors to ensure long-term stable, reliable operation.
- Easy Maintenance: Easy-to-clean, built-in, detachable filter blocks dirty water from entering the inlet valve.

Specification Parameters

- Working temperature: 35.6°F -113°F
- Working pressure: Dynamic pressure of 0.07Mpa - Static pressure of 0.8Mpa
- Power: DC 6V (4 AA alkaline batteries)
- Water inlet: Bottom-in and back-in
- Water inlet thread: External thread G 1/2" or 15 / 16-14 UNS - 1A
- Applicable tank height: The height between flush valve installation base to the inside top of tank is more than 300mm
- Sensing distance: Less than 30mm
- Adjustable sensor module level: Total 255 levels (1 - FF level)

NOTE: Batteries not included.

Troubleshooting

1. Water is not shutting off after first use.
Cause: The solenoid valve inside the valve body is automatically opened due to heavy movement during shipping or installation.
Resolution: Flush once, or disconnect the battery box and wait for 30 seconds, then reconnect the battery box.
2. Water line is too high or too low.
Cause: Inlet valve is not adjusted to a suitable position.
Resolution: Adjust the water level to the appropriate water level.
3. Inlet valve does not shut off.
Cause: The valve body float is blocked and does not float in place. The valve body has a leak. the valve body water level is higher than the overflow pipe.
Resolution: Check if the float is stuck and can move up and down freely. Make sure there are no leaks from the body valve. Adjust valve body water level and installation height.
4. Inlet valve does not turn on.
Cause: Water supply valve is off or the inlet valve float is blocked and does not float in place. The filter screen is dirty or the tube was not installed properly.
Resolution: Turn on the water supply valve, check if the float is stuck and can move up and down freely. Clean the filter screen. Re-install the tube correctly.
5. Little or no flush.
Cause: The piston or lift rod is stuck or the battery is low. The filter screen is dirty or the flush volume is not adjusted properly. The tube may not have been installed properly.
Resolution: Check if the piston and lift rod move freely. Try to change the battery. You may need to clean the filter screen. Re-install the tube correctly.
6. Valve body leakage.
Cause: Debris in water is affecting the valve. The refill tube may not have been installed properly. The valve and base may not fit properly. The wire may be twisted.
Resolution: Remove, clean and reassemble the valve body. Try to adjust the refill tube and make sure the tube is above the water surface, then reassemble. Try to adjust the position of the wire so it does not twist.



1-434-MADISON

(623-4766)

19 Stults Road

Dayton, NJ 08810

www.swissmadison.com

ONE YEAR LIMITED WARRANTY

Swiss Madison® products are made with quality materials and excellent craftsmanship to provide our customers with beautiful, durable, long-lasting products. Should there be any defects in materials or craftsmanship under regular use that are discovered within the first year of installation, Swiss Madison® will provide replacement parts at no charge, or at its discretion, replace any product or part of the product that is deemed defective, under normal installation, use, service or maintenance. This warranty applies only to the original purchaser. Proof of purchase will be required in the instance of a claim.

Swiss Madison® recommends all installations of Swiss Madison® products to be conducted by a licensed, professional plumber or contractor. Swiss Madison® will not be held responsible for any damage or product failure due to improper installation, misuse, or failure to utilize a licensed professional for installation. Swiss Madison® is not responsible for any installation or removal costs.

This One Year Limited Warranty Will Be Voided If:

- The installation recommendations were not followed by the installer
- The product has been moved from its initial place of installation
- The product has in any way been modified from its packaged state
- The product has been subjected to improper maintenance, abuse, misuse, excessive use of chemicals, accidents, or other damages, etc.

Swiss Madison® makes no implication that its products comply with any local building or plumbing codes. It is the consumer's responsibility and obligation to determine local code compliance prior to and during installation. This warranty extends only to the original purchaser and first consumer.

Swiss Madison® is not responsible for any special, incidental or consequential damages associated with the installation, replacement, return or use of the original purchaser's product. This includes, but is not limited to: freight costs, labor, travel time, lost profit, home damages and other contingent liabilities and costs (including, without limitation, costs associated with 'professionals' or 'experts', investigations, audits, analyses, attorneys and any other professional/hired services).

The Swiss Madison® warranty is a comprehensive and explicit limit of liability. All items not disclosed within the warranty are not addressable within the responsibility of Swiss Madison®. Certain states have variances regarding implied warranties; in those situations, we remain fully compliant.

**If you have any questions or concerns, please contact us directly at
1-434-MADISON (623-4766)**

WARNING: Contents of your order may contain sharp and possibly other harmful pieces and may cause hazard to children and adults. Swiss Madison® is not responsible in any way for personal damages.