

# OPERATING INSTRUCTIONS

PLEASE READ THIS MANUAL CAREFULLY BEFORE USING

**SPT<sup>®</sup>**

**RF-180SS (Stainless Steel)  
RF-180W (White)**

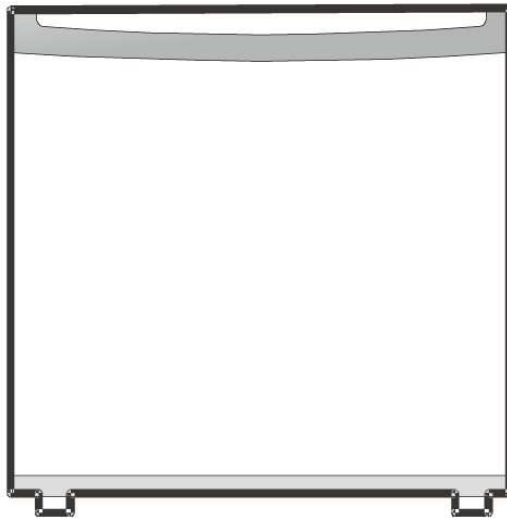

## PARTS IDENTIFICATION

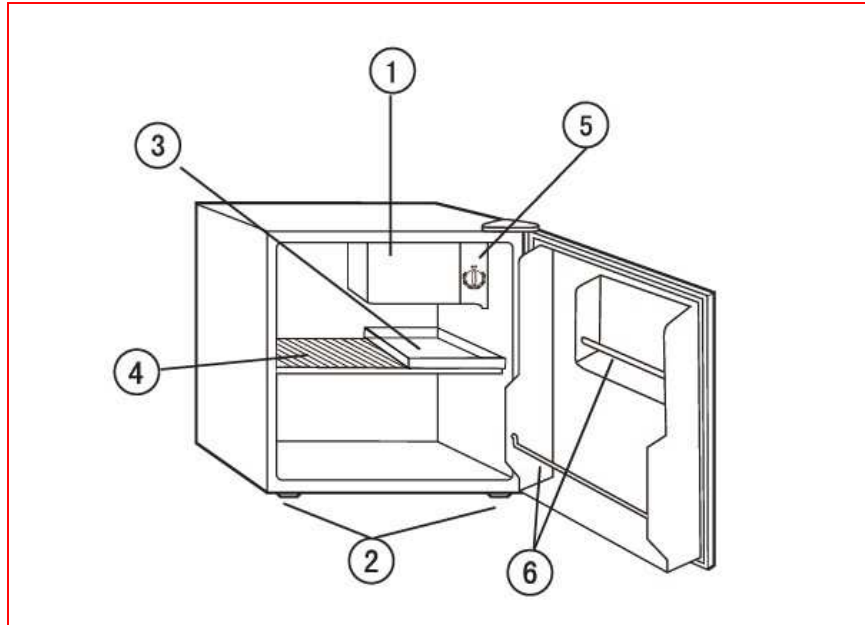

1. Freezer Compartment
2. Adjustable Leveling Legs
3. Drip Tray
4. Full-width Shelf
5. Temperature Control
6. 1 Full and 1 Half-width Door Storage

Note: This figure is only a sketch of the refrigerator. The actual product may differ slightly.

# PREPARING TO INSTALL

READ THESE INSTRUCTIONS COMPLETELY AND CAREFULLY

## Ventilation

There is need of good ventilation around the refrigerator for dissipation of heat, high efficiency of refrigeration and low power consumption. For this purpose, following clearance is needed for proper air circulation:

**Back:** 4" (100mm) from the wall

**Sides:** 8" (200mm)

**Top:** 12" (300mm)

- A clear space should be left to open the door to 160°

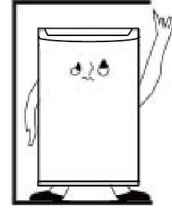

---

## Protection from Moisture

Avoid placing unit where heavy moisture is present, this is to minimize possibility of metal parts rusting. Never spray water onto the unit. Never spray water directly onto the unit – which may damage the insulation.



---

## Protection from Heat

Keep unit away from any heat source and direct sunlight.



---

## Location

Unit should be placed on a flat and solid ground, which can support the refrigerator when fully loaded. Adjust the leveling legs so the unit is firmly positioned on the floor. Do not place unit near anything that may echo.

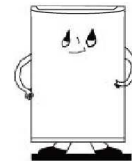

---

## Keep Away from Danger

Do not place refrigerator near any combustibles such as gas, petrol, alcohol, lacquer, banana oil and etc. The above mentioned should not be stored in the refrigerator.



---

## Moving

Secure all loose items (such as shelves and ice tray). Unit should never be set horizontally, upside down or declined more than 45°.



## SAFETY INSTRUCTIONS

### WARNING!

Use this appliance only for its intended purpose as described.

#### Power Supply

This unit is applied with power supply of single phase alternating current of 115V~, 60Hz. If fluctuation of voltage is so large that the voltage exceeds the above scope, it is suggested to apply A.C. Automatic voltage regulator to the refrigerator. This appliance is equipped with a 3-prong (grounding) plug which mates with a standard 3-prong wall outlet. **DO NOT, UNDER ANY CIRCUMSTANCES, CUT OR REMOVE THE THIRD (GROUND) PRONG FROM THE POWER CORD.** If you have only a 2-prong wall outlet, it is your responsibility to have it replaced with a properly grounded 3-prong wall outlet.

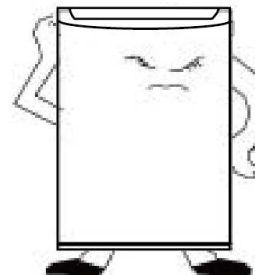

---

#### Power Cord

Be sure the cord is not folded into coil during operation. Keep cord away from the compressor (located at the back of the unit), due to its high surface temperature when operating. We strongly suggest against the use of an extension cord. However, if one must be used, the extension cord must be UL-listed, with grounding type plug and electrical rating matching that of the unit. Contact the manufacturer immediately should the cord be frayed or damaged.

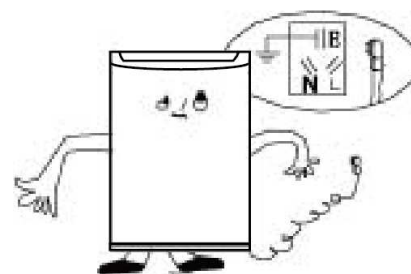

---

#### Safety Precautions

When using electrical appliances, basic safety precautions should be followed, including the following:

- Refrigerator should be installed and positioned according to the Installation instructions.
- Do not allow young children to climb or play with the refrigerator.
- Never store gasoline or other flammables in this appliance.
- Clearance between the doors and cabinets are quite small, keep fingers out of these areas. Be extra cautious when children are in the area.
- Turn the temperature control knob to the OFF (0) position and unplug before cleaning or maintenance.
- Turn the temperature control knob to the OFF (0) position and unplug before replacing light bulb.
- To prevent risk of child entrapment, remove doors before disposing the refrigerator.
- Under federal law, refrigerants must be removed prior to product disposal. Check with the company handling the disposal for further instructions.

## DOOR REVERSAL

If you wish to change the door opening direction, follow the instructions below:

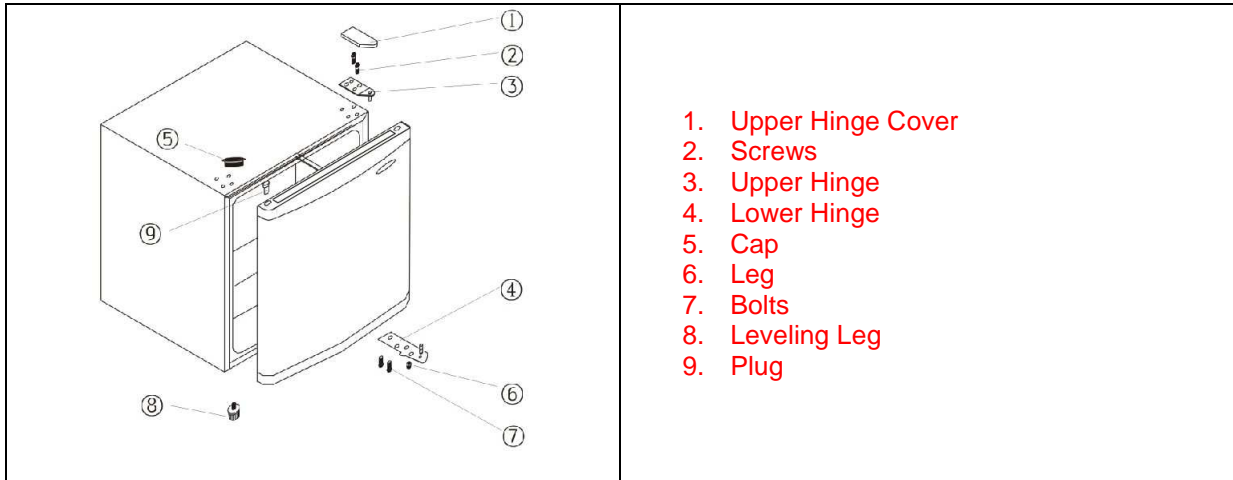

1. Remove the Upper Hinge Cover (1).
2. Using a flat screw-driver, pry out the Cap (5).
3. Remove the two screws (2) on the Upper Hinge (3).
4. Carefully lift the door and place on a padded surface to prevent scratching.
5. Remove the Plug (9) and transfer it to the uncovered hole on the right side. Be sure to insert firmly.
6. Remove the two bolts (7) from the Lower Hinge (4).
7. Remove the Leveling Leg (8) and transfer to the right side.
8. Set the door back in place, ensure the pin enters the bushing at the lower frame section.
9. Secure the Upper Hinge (3) on the left side, ensure the pin enters the bushing on the upper frame section.
10. Loosely secure the Lower Hinge (4) on the left – do not tighten until door is in the closed position and leveled.
11. Cover the right screws holes with the Cap (5)
12. Replace the Upper Hinge Cover (1).

## TEMPERATURE CONTROL

### Setting the Temperature Control Knob

- The settings of the temperature control are "0,1,2,3,4,5,6,".
- 0 is OFF and 6 is the coldest setting.
- The first time you turn on the unit, set the temperature control to "6" position. After 20 minutes, adjust the temperature control setting to "4" – which is the recommended setting for home or office use.
- The temperature range is approximately 32 ~ 50°F

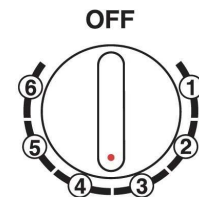

### NOTE

- Turning the temperature control to "0" stops the cooling cycle, but does not shut off the unit.
- If the unit is unplugged, power lost or turned off, please wait 10 minutes before restarting the unit. The unit will not start if you attempt to restart before this time delay.
- It is strongly suggested to place this refrigerator in the coolest area of the room, which can help conserve energy consumption. If the ambient temperature is too high, the refrigerator may not be able to target the set temperature.

## CARE AND MAINTENANCE

### Defrosting

Moisture contained in food and air may form a layer of frost inside the unit after a period of use. Defrost when frost becomes ¼" thick.

**Never use a sharp or metallic instrument to scrape off frost – this will damage the inner casing or the cooling coils.**

Defrosting in the freezer chamber is operated manually:

- Before defrosting, remove food and ice tray from the refrigerator.
- Turn the temperature control knob to OFF (0) position.
- Leave the door open until ice and frost dissolves thoroughly.
- Empty the drip tray and wipe the interior dry with a soft cloth.
- To speed up the defrosting process, you may put a bowl of warm water (about 120°F) into the chamber.
- Be sure to set the temperature control knob back to desired setting after defrosting.

DO NOT pour hot water directly into compartment or heat with hair dryer while defrosting, which may deform the inner case.

---

### Maintenance

The refrigerator should be cleaned and maintained once a month.

- When performing maintenance, make absolutely sure that the power plug is disconnected.

Cleaning the Inside and Outside Cabinets

- Wipe the cabinets with a clean cloth.
- If dirty, dampen cloth with mild detergent and wipe clean with damp cloth.
- Dry with a clean, soft cloth.
- Polish the exterior with a small amount of glass wax
- Do not use scouring pads powdered cleaners, bleach, alcohol, kerosene, chemical cloth and etc.
- Do not spray water directly onto the refrigerator.
- Be sure to frequently clean the sealing rubber bars on the door.
- If the plastic parts remain contaminated to oil for a long period of time, they will easily age and possibly crack.
- The drain pan gets dirty easily and may produce bad odor. Clean the pan frequently.

Prevent Odors

- Place an open box of baking soda inside the refrigerator.

## TROUBLESHOOTING

1. Refrigerator does not operate
  - Check if there is a power failure
  - Check if power plug is securely plugged into outlet
  - Check if fuse is blown or circuit breaker tripped
  - Check if control is set to OFF (0) position
2. Refrigerator is cooling excessively
  - Temperature control dial is set too high
  - If contents containing high amount of moisture is placed directly under the cool air outlets, they will freeze easily. This does not indicate a malfunction.
3. Refrigerator is not cooling sufficiently
  - Contents may be packed too tightly together, which blocks the airflow.
  - Something hot may have been recently placed in the unit.
  - Door was not closed properly.
  - Door gaskets may be damaged.
  - Refrigerator may not be well ventilated.
  - Possible insufficient clearance between the refrigerator and the walls.
  - Temperature control knob not set properly.
4. Defrosting water overflows onto the floor
  - Check if drain pipe and drain hose are not clogged.
  - Check if the drain pan is housed properly.
5. The refrigerator's front cabinet heats up
  - In order to safeguard against condensation, there is an anti-condensation pipe that heats up the front cabinet. A warm front cabinet does not indicate a malfunction.
6. Condensation forms on the outside of the cabinets
  - Condensation may form on the outside when humidity is high. This is the same result as condensation formed when chilled water is poured into a glass. It does not indicate a failure. Simply wipe dry with a soft cloth.
7. Condensation forms on the inside
  - Too frequent or too long door openings. In humid conditions, air carries moisture into refrigerator when door is opened.
8. When you hear a water flowing sound
  - This is sound of refrigerant flowing. It is not a malfunction.
9. The cabinet's side panel heats up
  - The side panels will heat up when door is opened frequently, when starting the unit and when unit operates in high ambient temperature. This results from dissipation of heat and not a malfunction.
10. Vibration or rattling sound
  - Refrigerator is not set on an even surface
  - Front leveling legs need adjusting



## **Your Guarantee**

**If this product is found to be faulty as a result of faulty materials or workmanship within one year from date of purchase, it will be repaired free of charge.**

This guarantee is subject to the following terms:

- Sunpentown must be notified of the fault.
- Proof of purchase must be presented to Sunpentown's nominated representative.
- The warranty will be void if the product is modified, misused or repaired by an unauthorized person.
- The warranty after repair will not be extended beyond the original one-year period.
- All replacement parts will be new or reconditioned.
- Parts, which are replaced, become the property of Sunpentown.
- The warranty applies for the use of the product in the USA only.

What is NOT COVERED:

- Warranty does not include freight charges.
- Incidental or consequential damage caused by possible defects with this product.
- Damage to product caused by improper power supply voltage, accident, fire, floods or acts of nature.
- Failure of product resulting from unauthorized modifications to the product.
- Improper installation or failure to perform the necessary maintenance.

This GUARANTEE is in addition to your Statutory Rights

**SUNPENTOWN INTERNATIONAL INC.**  
**14625 Clark Avenue, City of Industry, CA 91745**  
**Tel: 626.336.2299 · Fax: 626.336.7116**  
**service@sunpentown.com**  
**[www.sunpentown.com](http://www.sunpentown.com)**