

STERLING®

A KOHLER COMPANY

SPRINGDALE®

UNDERCOUNTER KITCHEN SINK 11449

Features

- Includes SilentShield® sound-absorption technology
- Satin finish
- 18-gauge stainless steel
- Undermount rimless design
- Undercounter double (large/medium) compartment kitchen sink
- 16-1/4" (41.3 cm) x 20-1/2" (52.1 cm) x 8" (20.3 cm)

Codes/Standards Applicable

Specified model meets or exceeds the following:

- ASME A112.19.3/CSA B45.4

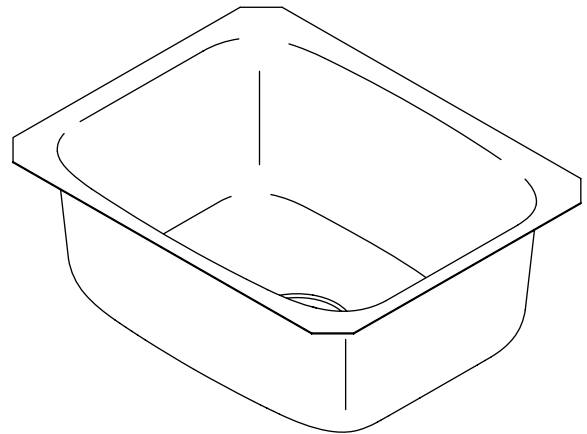

Colors/Finishes

- NA: None applicable

Specified Model

Model	Description	Colors/Finishes
11449	Undercounter kitchen sink	<input type="checkbox"/> NA

SPRINGDALE®

Technical Information

Fixture*:	Basin area
Sink	14-1/4" (36.2 cm) x 18-1/2" (47 cm)
Drain hole	3-3/4" (9.5 cm) D.
* Approximate measurements for comparison only.	

Included components:	
Hardware kit	91915
Cut-out template	1061196-7

Installation Notes

Install this product according to the installation guide.

Use the supplied cut-out template to select either a hidden or exposed rim.

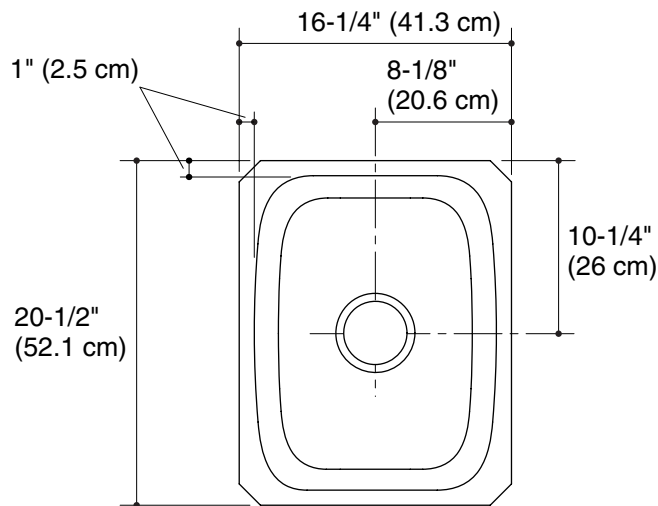

Mounting bracket assembly provides a secure installation.

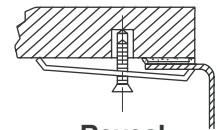

Reveal

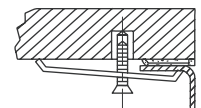

No Reveal

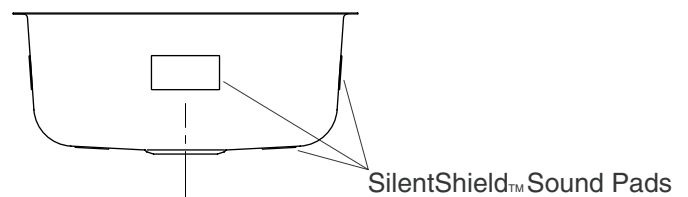
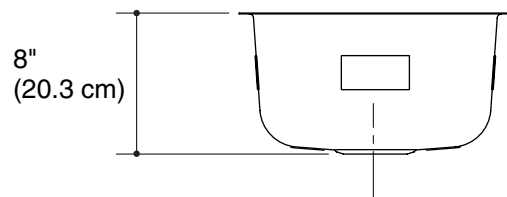

Product Diagram