

**STANLEY**<sup>®</sup>

Security Solutions



# SLIDING & FOLDING DOOR HARDWARE

COMMERCIAL HARDWARE

**STANLEY**<sup>®</sup>

**TABLE OF CONTENTS**

Company history .....2  
 Nomenclature explained.....3  
 BiFold hardware .....3-13  
 BF20 .....4, 5  
 BF30 .....6-9  
 BF50 .....10, 11  
 BF125N .....12, 13  
 ByPass hardware .....14-19  
 BP60 & BPD60 .....14-17  
 BP150N & BPD250N .....18, 19  
 Pocket door hardware .....20-23  
 PD75 .....20  
 PD150N .....21  
 PDF150N & PDF250N .....22, 23

**COMPANY HISTORY**



**The Stanly Works  
 New Britain, CT in 1843**

As a young man in 1843, Frederick T. Stanley founded The Stanley Works – a small company located in New Britain, Connecticut that manufactured hinges, bolts and other door hardware in a one-story wooden building.

Mr. Stanley’s vision was to create a hardware company with unsurpassed customer service, product innovation and integrity – and to offer products that would become the first choice among professionals around the world.

With the early success of this mission and an increasing demand for his high-quality goods, Mr. Stanley began exporting his products in the 1870s.

Today, Stanley is a global organization supplying hardware and tools for the architectural, consumer, industrial and residential markets worldwide. Utilizing state-of-the-art research, manufacturing and quality-control capabilities, Stanley continues to deliver the innovative, high quality products that have made the Stanley name synonymous with the highest craftsmanship and dependability for more than 160 years.

To our valued customers, we appreciate your loyalty over the years and proudly present our Architectural Hardware offering.

Commercial Customer Service: 1-800-337-4393  
[www.stanleyhardware.com](http://www.stanleyhardware.com)

# SLIDING AND FOLDING DOOR HARDWARE

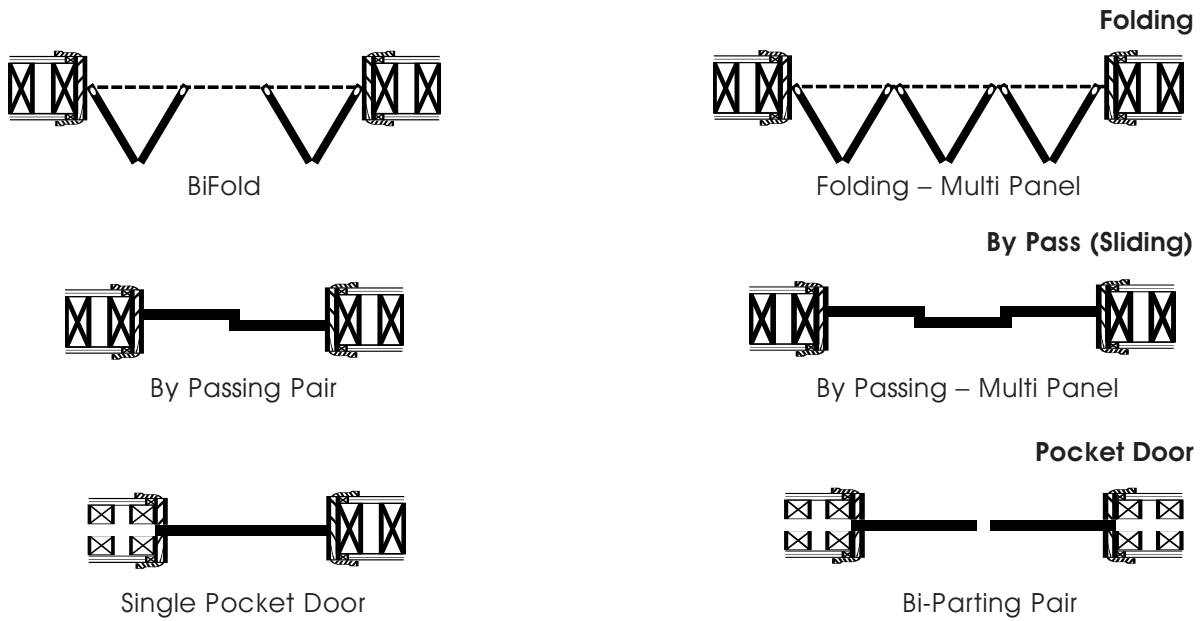

Nomenclature: Application + Weight + Component = Class Number

Application	Weights		Components	
<b>BF = BiFold</b>	20 lbs	9 Kg	Track = <b>01-09</b>	
	30 lbs	14 Kg	Pivot Brackets = <b>10-19</b>	
	50 lbs	23 Kg	Snuggers = <b>20-29</b>	
	125 lbs	57 Kg	Pivots = <b>30-39</b>	
<b>BP = ByPass</b>	60 lbs	27 Kg	Hangers = <b>40-49</b>	
	150 lbs	68 Kg	Pulls = <b>60-69</b>	
	250 lbs	113 Kg	Bottom Guides = <b>70-79</b>	
<b>PD = Pocket Door</b>	75 lbs	34 Kg	Jamb Brackets = <b>80-89</b>	
	150 lbs	68 Kg	Bottom Guide Track = <b>90-99</b>	
<b>PDF = Pocket Door Frame</b>	150 lbs	68 Kg		
	250 lbs	113 Kg		

Example: BF (Bi-Fold) – 125 (125 lbs.) – 41 (Hanger)

## Metric Conversions

1 in. = 25.4 mm    1 mm = .039 in.

Inches	Millimeters	Inches	Millimeters
1/16.....	2	1-3/4.....	44
1/8.....	3	2.....	51
3/16.....	5	2-3/4.....	70
1/4.....	6	3-1/2.....	89
5/16.....	8	12.....	305
3/8.....	10	18.....	457
7/16.....	11	24.....	610
1/2.....	13	30.....	762
9/16.....	15	36.....	914
5/8.....	16	48.....	1219
11/16.....	18	60.....	1524
3/4.....	19	72.....	1829
13/16.....	21	84.....	2134
7/8.....	22	96.....	2438
15/16.....	24	120.....	3048
1.....	25	144.....	3658
1-3/8.....	35	192.....	4877

## Average Door Weight Chart

Door Thickness	Inches		mm		Inches		mm		Inches		mm	
	13/8"	35	13/4"	44	2"	51						
	lbs/ft <sup>2</sup>	kg/m <sup>2</sup>	lbs/ft <sup>2</sup>	kg/m <sup>2</sup>	lbs/ft <sup>2</sup>	kg/m <sup>2</sup>						
<b>Hollow Core</b>	2	9.8	2 1/2	12.2	—	—						
<b>Solid Core</b>	3 1/2	17	4 1/2	22	5 1/4	25.6						
<b>Pine (White)</b>	3	14.6	3 1/2	17	4	19.5						
<b>Oak</b>	5	24.4	7	34.2	8	39						
<b>Ash</b>	4	19.5	5	24.4	6	29.3						
<b>Fir</b>	3	14.6	3 1/2	17	4	19.5						
<b>Birch</b>	4 1/4	20.8	5 1/2	26.9	6 1/4	30.5						
<b>Mahogany</b>	3 1/2	17	4 1/2	22	5 1/4	25.6						

# BiFold Hardware

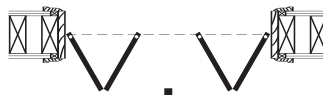

## BF20

### 20 lb. Panel Bifold

For installation of 2 or 4, 7/8" to 1 3/8" thick panels weighing up to 20 lbs. each.

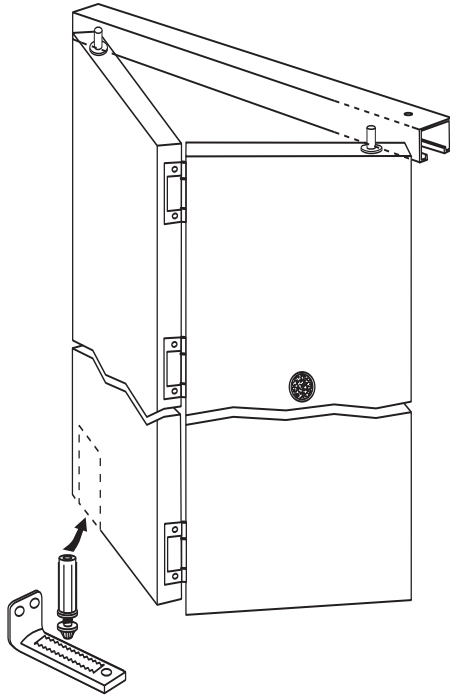

#### Features

- Snug-fit top pivot and roller guide for easy installation
- Durable pre-painted track
- All metal components galvanized against corrosion
- Easily adjustable after installation

#### ANSI Reference

- BF20 conforms to ANSI A156.14 type D8623

#### Cross Reference

- STANLEY 2800 series
- Crowder CF-100
- Sterling 1530/8000
- Lawrence C649S/L850S

## Sizing Information

### Finished Opening/Panel Dimensions

#### To determine panel width:

Panel width = known finished opening width divided by number of panels, less 1/4"

#### To determine opening width:

Opening width = known finished panel width plus 1/4", multiplied by number of panels

**Door height** = 1 1/2" to 2" less than finished opening height

## Installation Detail

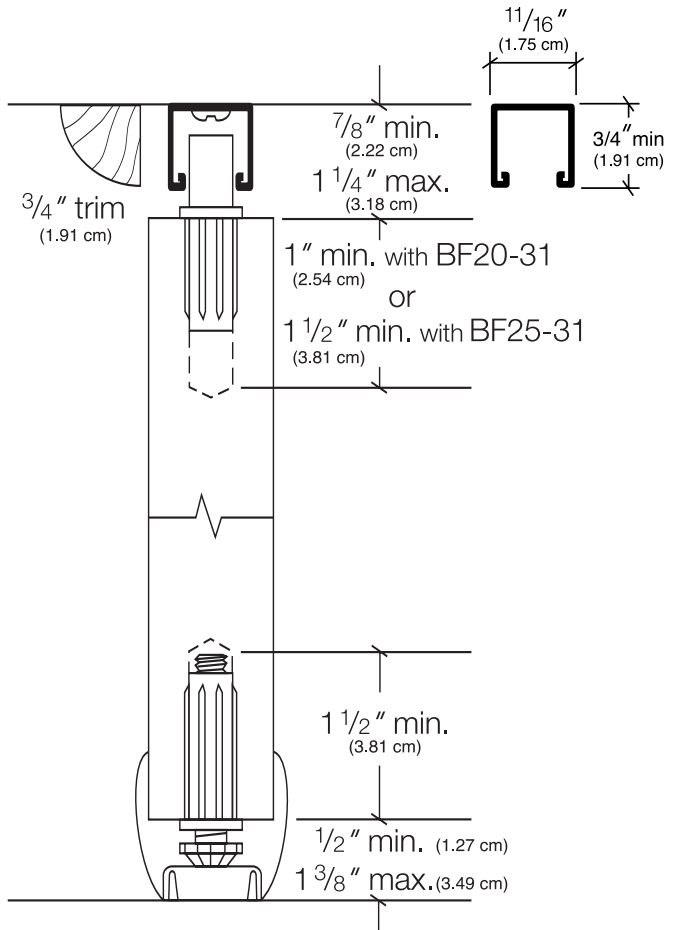

## Track with Pivot Bracket

Track Number	Number of Panels	Length	Finish	Case Qty.	Case Weight	EDP Number
BF20-01-24	2	23 3/4"	WHITE	25 EA.	13 LBS	52 4252 001
BF20-01-30	2	29 3/4"	WHITE	25 EA.	16 LBS	52 4292 001
BF20-01-32	2	31 3/4"	WHITE	25 EA.	17 LBS	52 4316 001
BF20-01-36	2	35 3/4"	WHITE	25 EA.	18 LBS	52 4336 001
BF20-01-48	4	47 3/4"	WHITE	25 EA.	26 LBS	52 4344 001
BF20-01-60	4	59 3/4"	WHITE	25 EA.	31 LBS	52 4368 001
BF20-01-72	4	71 3/4"	WHITE	25 EA.	36 LBS	52 4400 001

**Hardware Components**

**BF20**

Steel Track	EDP No.
<b>BF20-01-XX - White</b>	**

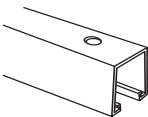
Pivot Bracket	Case Qty.	EDP No.
<b>BF20-10</b>	200 ea.	52 4236 001

Snugger	Case Qty.	EDP No.
<b>BF20-23-4Door</b> 3/4"-7/8" edge to hole	200 ea.	52 4297 001

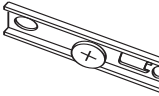
Pivots	Case Qty.	EDP No.
<b>BF20-31-Top Pivot Guide</b>	400 ea.	52 4208 001
<b>BF30-33-Bottom Pivot</b>	200 ea.	52 4212 001

Top Guide Pivot	Case Qty.	EDP No.
<b>BF25-31</b> For 25 lb. panels	200 ea.	52 4452 001

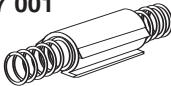
Jamb Bracket	Case Qty.	EDP No.
<b>BF30-81- 3/4" screws</b> Easy horizontal adjustment	200 ea.	52 4200 001
<b>BF50-81- 3/4" screws</b> With pivot block for mounting above floor	200 ea.	52 2252 001
<b>BF50-83</b> Floor bracket for slab floor installations	200 ea.	52 2264 001

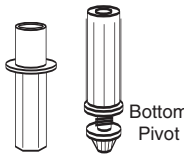
Aligners	Case Qty.	EDP No.
<b>BF50-72</b> For use in four door installations	100 pr.	52 2224 001

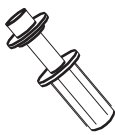
Knobs	Case Qty.	EDP No.
<b>BF50-61- Plastic</b>	100 pr.	52 1244 001
<b>BF50-62- Wood</b>	100 pr.	52 1280 001
<b>BF50-65- Brass</b>	400 pr.	52 1236 001

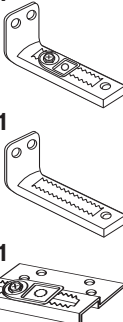

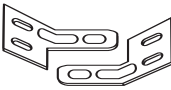
Hinges	Length	Case Qty.	EDP No.
<b>220-3</b> Non-mortise, In-line holes, w/screws, brasstone	3"	300 pr.	52 1012 001
<b>220-3LS</b> Non-mortise, In-line holes, no screws	3"	300 pr.	52 1016 001
<b>221-3</b> Non-mortise, offset holes, no screws, brasstone	3"	300 pr.	52 1032 001
<b>224-Satin Brass Finish</b> Flatback Hinge, no screws	300 pr.	52 1052 001	2 1/2" x 1 5/8"
<b>234-Bright Zinc Finish</b> Flatback Hinge, no screws	300 pr.	52 1076 001	2 1/2" x 1 5/8"
<b>224RC-Satin Brass Finish</b> Flatback Hinge, no screws with raised countersinks for Medium Density Fiberboard (MDF) panels	300 pr.	52 1053 001	2 1/2" x 1 5/8"

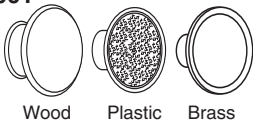

Screws	Case Qty	EDP No.
<b>220-121SC</b> Brass Tone Finish Drill Point Screws for 220 hinge #2 Phillips drive #6 x 7/8" flat head	600 sets	52 1024
<b>221-SC</b> Brass Tone Finish Screws for 220-3/221-3 hinge #2 Phillips drive #6 x 7/8" flat head	600 sets	52 1040
<b>214-121SC</b> Brass Tone Finish Self drilling screws for 224/234 hinge #2 Phillips drive #8 x 5/8" pan head	300 sets	52 1004
<b>214-SC</b> Brass Tone Finish Screws for 224/234 hinge #2 Phillips drive #8 x 5/8" pan head	300 sets	52 1000

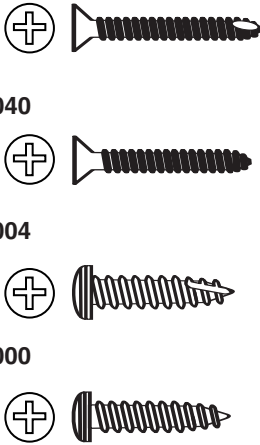

**BF20 Bagsets**

CLASS NO.	PART DESCRIPTION	EDP No.
BF30-81	Bracket Jamb Blue Zinc	52 4492 001
BF20-21	(2DR) Snugger	2867-2
BF20-31	Top Guide/Pivot	1
BF30-33	Bottom Pivot	1
BF50-61	Plastic Knob	1
	#8 x 1 1/2" Flat Head Screw	5
	#8 x 1 3/4" Truss Head Knob Screw	1
	#8 x 3/4" Flat Head Screw	5

# BiFold Hardware

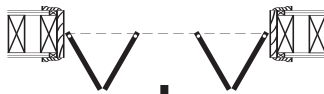

## BF30

### 30 lb. Panel Bifold

For installation of 2 or 4, 7/8" to 1 3/8" thick panels weighing up to 30 lbs. each.

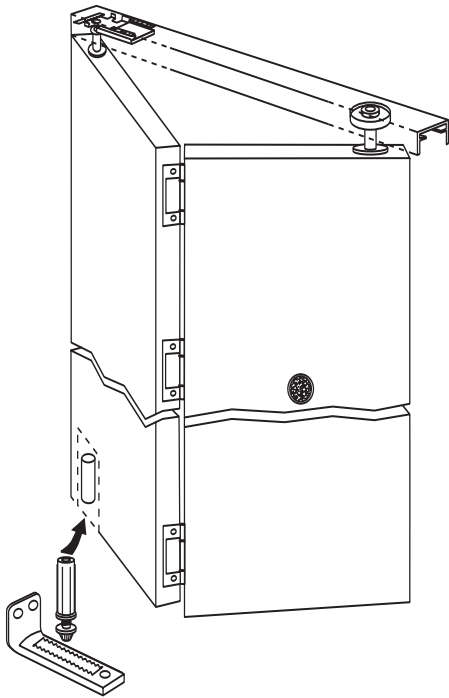

#### Features

- Spring loaded top pivot and roller guide for easy installation
- Permanently lubricated roller guide
- Durable pre-painted track
- All metal components galvanized against corrosion

#### ANSI Reference

- BF30 conforms to ANSI A156.14 type D8622, D8662

#### Cross Reference

- STANLEY 2400/2900 series • Cox 43/48
- Hager CD-2670 • Lawrence C 620/640
- Johnson 1838 • Sterling 1540/9000

## Sizing Information

### Finished Opening/Panel Dimensions

#### To determine panel width:

Panel width = known finished opening width divided by number of panels, less 1/4"

#### To determine opening width:

Opening width = known finished panel width plus 1/4", multiplied by number of panels

Door height = 1 5/8" less than finished opening height

## Installation Detail

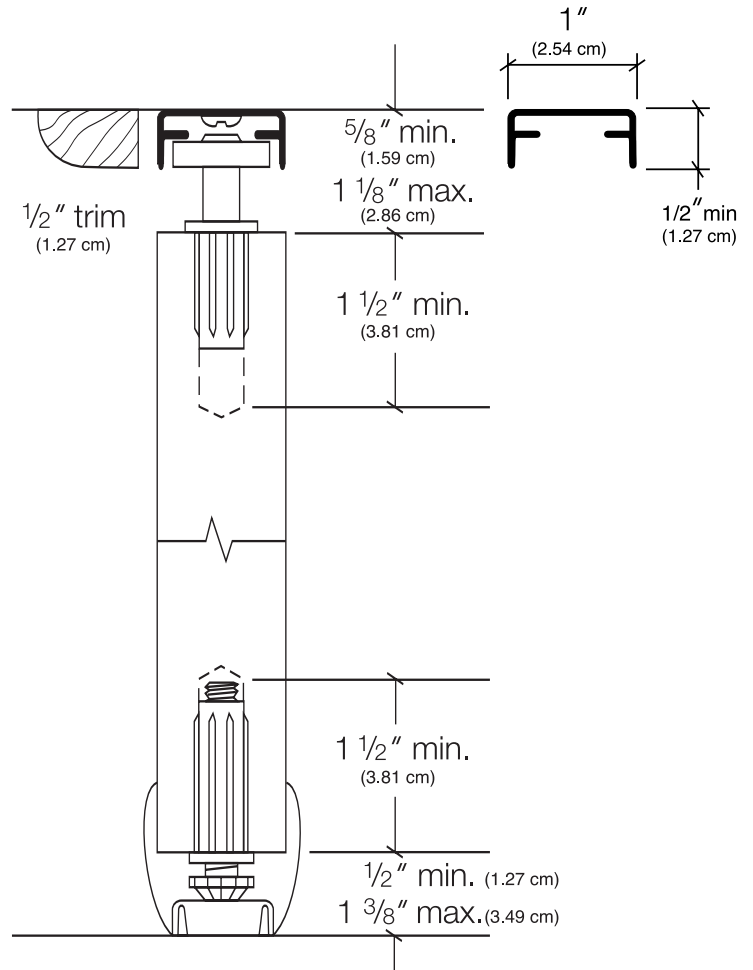

## Complete Packaged Sets

### RETAIL PACKAGING

Minimum 1" thick panels

Description	Set No.	Case Qty.	Case Weight	EDP Number
2 Door 24" opening	BF30-00-24	6 sets	9 lbs	40 2022
2 Door 30" opening	BF30-00-30	6 sets	10 lbs	40 2025
2 Door 36" opening	BF30-00-36	6 sets	12 lbs	40 2032
4 Door 48" opening	BF30-00-48	6 sets	19 lbs	40 2044
4 Door 60" opening	BF30-00-60	6 sets	21 lbs	40 2054
4 Door 72" opening	BF30-00-72	6 sets	24 lbs	40 2064



**Track with Pivot Bracket**

Track No.	Number of Panels	Length	Finish	Case Qty.	Case Weight	EDP Number
BF30-01-24	2	23 3/4"	WHITE	25 EA.	14 LBS	52 2004 001
BF30-01-28	2	27 3/4"	WHITE	25 EA.	16 LBS	52 2024 001
BF30-01-30	2	29 3/4"	WHITE	25 EA.	17 LBS	52 2032 001
BF30-01-32	2	31 3/4"	WHITE	25 EA.	18 LBS	52 2052 001
BF30-01-36	2	35 3/4"	WHITE	25 EA.	19 LBS	52 2060 001
BF30-01-36	4	35 3/4"	WHITE	25 EA.	22 LBS	52 2064 001
BF30-01-48	4	47 3/4"	WHITE	25 EA.	28 LBS	52 2068 001
BF30-01-60	4	59 3/4"	WHITE	25 EA.	34 LBS	52 2092 001
BF30-01-72	4	71 3/4"	WHITE	25 EA.	40 LBS	52 2120 001
BF30-01-84	4	83 3/4"	WHITE	25 EA.	48 LBS	52 2144 001
BF30-01-96	4	95 3/4"	WHITE	25 EA.	54 LBS	52 2148 001

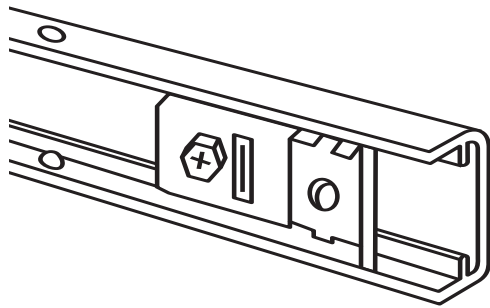

**DIMPLED STEEL TRACK**

Track No.	Number of Panels	Length	Finish	Case Qty.	Case Weight	EDP Number
BF30-02-24	2	23 3/4"	WHITE	25 EA.	14 LBS	52 2284 001
BF30-02-30	2	29 3/4"	WHITE	25 EA.	17 LBS	52 2300 001
BF30-02-36	2	35 3/4"	WHITE	25 EA.	19 LBS	52 2316 001
BF30-02-48	4	47 3/4"	WHITE	25 EA.	28 LBS	52 2320 001
BF30-02-60	4	59 3/4"	WHITE	25 EA.	34 LBS	52 2332 001
BF30-02-72	4	71 3/4"	WHITE	25 EA.	40 LBS	52 2344 001

**Packaged Set Components**

Steel Track	EDP No.
<b>BF30-01-XX</b>	**

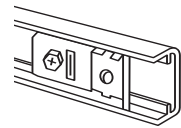

Snugger	Case Qty.	EDP No.
<b>BF30-22- 2Door</b>	<b>200 ea.</b>	<b>52 2240 001</b>
<b>BF30-24- 4Door</b>	<b>100 ea.</b>	<b>52 2244 001</b>



Top Guide Pivot/Guide Wheel – 7/16" Dia. Body	Case Qty.	EDP No.
<b>BF50-34-Top Pivot</b>	<b>200 ea.</b>	<b>52 2272 001</b>
<b>BF30-35-Guide Wheel</b>	<b>200 ea.</b>	<b>52 2280 001</b>
<b>BF30-36-Bottom Pivot</b>	<b>200 ea.</b>	<b>52 3248 001</b>

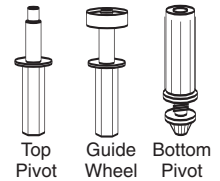

Jamb Bracket	Case Qty.	EDP No.
<b>BF30-81</b>	<b>200 pr.</b>	<b>52 4200 001</b>

Easy horizontal adjustment

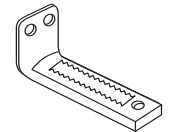

Aligners	Case Qty.	EDP No.
<b>BF50-72</b>	<b>100 pr.</b>	<b>52 2224 001</b>

For use in four door installations

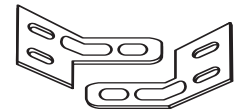

Knobs	Case Qty.	EDP No.
<b>BF50-62-Wood</b>	<b>100 pr.</b>	<b>52 1280 001</b>



Hinges	Length	Case Qty.	EDP No.
<b>221-3-Offset Holes</b>	<b>3"</b>	<b>300 pr.</b>	<b>52 1032 001</b>

Brass tone zinc finish

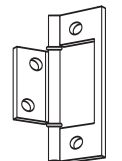

See next page for accessories

# BiFold Hardware



## BF30

### Hardware

### Accessories & Options

Pivot Bracket	Case Qty.	EDP No.
BF30-10	200 ea.	52 2236 001

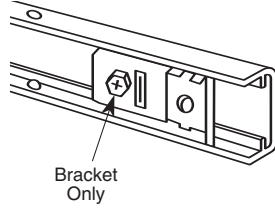

Top Guide Pivot/Guide Wheel – 3/8" Dia. Body		
BF30-31-Top Pivot	200 ea.	52 2612 001
BF30-32-Guide Wheel	200 ea.	52 2620 001
BF30-33-Bottom Pivot	200 ea.	52 4212 001

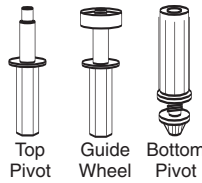

### Slide Guides

BF30-25	200 ea.	52 2372 001
---------	---------	-------------

Cushions door when opening, tensions doors in closed position

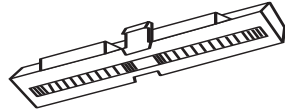

### Jamb Bracket

BF50-81	200 ea.	52 2252 001
---------	---------	-------------

3/4" flat head screws  
Easy horizontal adjustment

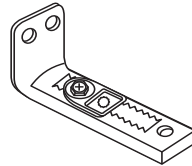

BF50-83	200 ea.	52 2264 001
---------	---------	-------------

Floor Bracket for slab floor installations

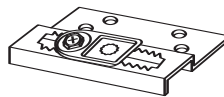

BF50-84	200 ea.	52 3236 001
---------	---------	-------------

3/4" flat head screws  
Heavy Duty Jamb Bracket for mounting above floor

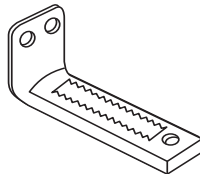

### Knob

BF50-65 - Brass	400 pr.	52 1244 001
BF50-61 - Plastic	100 pr.	52 1280 001

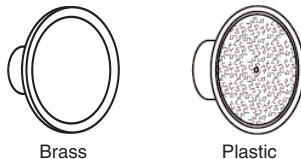

Hinges	Length	Case Qty.	EDP No.
220-3LS	3"	300 pr.	52 1016 001

Non-mortise, In-line holes, no screws

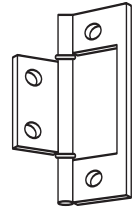

224- 2 1/2" x 1 5/8"	300 pr.	52 1052 001
----------------------	---------	-------------

Satin Brass Finish  
Flatback Hinge, no screws

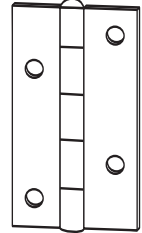

234- 2 1/2" x 1 5/8"	300 pr.	52 1076 001
----------------------	---------	-------------

Bright Zinc Finish Flatback  
Hinge, no screws

224RC- 2 1/2" x 1 5/8"	300 pr.	52 1053 001
------------------------	---------	-------------

Satin Brass Finish Flatback  
Hinge with raised countersinks for  
Medium Density Fiberboard (MDF)  
panels no screws

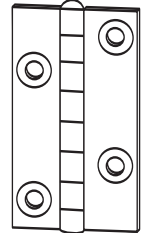

Screws	Case	EDP No.
220-121SC	600 sets	52 1024 001

Brass Tone Finish  
Drill Point Screws for 220 hinge  
#2 Phillips drive  
#6 x 7/8" flat head



221-SC	600 sets	52 1040 001
--------	----------	-------------

Brass Tone Finish  
Screws for 220-3/221-3 hinge  
#2 Phillips drive  
#6 x 7/8" flat head



214-121SC	300 sets	52 1004 001
-----------	----------	-------------

Brass Tone Finish  
Self drilling screws for 224/234  
hinge #2 Phillips drive  
#8 x 5/8" pan head



214-SC	300 sets	52 1000 001
--------	----------	-------------

Brass Tone Finish  
Screws for 224/234 hinge  
#2 Phillips drive  
#8 x 5/8" pan head





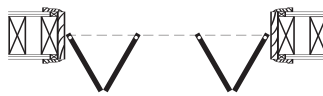

**When Ordering, Please Specify EDP Number  
BF30 Bifolding Hardware Bagsets**

EPD No. Bagset Catalog No.	52 2007 001 2453	52 2011 001 2454	52 2012 001 2455	52 2015 001 2386
<b>CLASS NO. PART DESCRIPTION</b>				
BF30-83 Pivot Locator	1	1	1	
BF30-81 Bracket Jamb Blue Zinc	1	1	1	1
BF30-22 2-Door Snugger	1	1	1	
BF30-24 4-Door Snugger	1	1	1	
BF30-31 Top Pivot	2	1		
BF50-34 Top Pivot				2
BF30-33 Bottom Pivot	1	1	1	
BF30-36 Bottom Pivot				1
BF30-25 Slide Guide				1
BF30-32 Guide Wheel	1	1	1	
BF50-61 Plastic Knob Tan		1		
BF50-62 Wood Knob	1			
Plastic Knob White				1
BF50-72 Aligner	1	1	1	1
#8 x 5/8" Pan Head Screw	2	2	2	2
#8 x 1-1/2" Flat Head Screw	5	5	5	2
#8 x 3/4" Flat Head Screw	5	5	5	
#8 x 1-3/4" Truss Head Knob Screw	1	1		
#8 x 1-1/4" Pan Head Screw				3
#8 x 1-3/4" Truss Head Mach. Screw			1	

EPD No. Bagset Catalog No.	52 2017 001 2400	52 2492 001 2381-M	52 2528 001 2385	52 3128 001 2568	52 2016 001 2405
<b>CLASS NO. PART DESCRIPTION</b>					
BF30-83 Pivot Locator	1				1
BF30-81 Bracket Jamb Blue Zinc	1				1
BF50-81 Adjustable Jamb Bracket		1	1	2	
BF30-22 2-Door Snugger	1				1
BF30-24 4-Door Snugger	1			1	1
BF50-34 Top Pivot	1	2	2	2	1
BF30-36 Bottom Pivot	1	1	1	2	1
BF30-25 Slide Guide		1	1		
BF30-35 Guide Wheel	1			2	1
BF50-61 Plastic Knob Tan	1				
F50-62 Wood Knob				2	1
BF50-65 Brass Knob			1		
BF50-72 Aligner	1		1	2	1
#8 x 5/8" Pan Head Screw	2		2	4	2
#8 x 1-1/2" Flat Head Screw	5	5	5	10	5
#8 x 3/4" Flat Head Screw	5	5	5	10	5
#8 x 1-3/4" Truss Head Knob Screw	1			2	1
#8 x 1-1/4" Pan Head Screw			3		
#8 x 1-3/4" Truss Head Mach. Screw			1		
#8 x 1-9/16" Truss Head Knob Screw			1		

# BiFold Hardware

## BF50

### 50 lb. Panel Bifold

For installation of 2 or 4, 1" to 1 3/4" thick panels weighing up to 50 lbs. each, or multi-panels weighing up to 30 lbs. each.

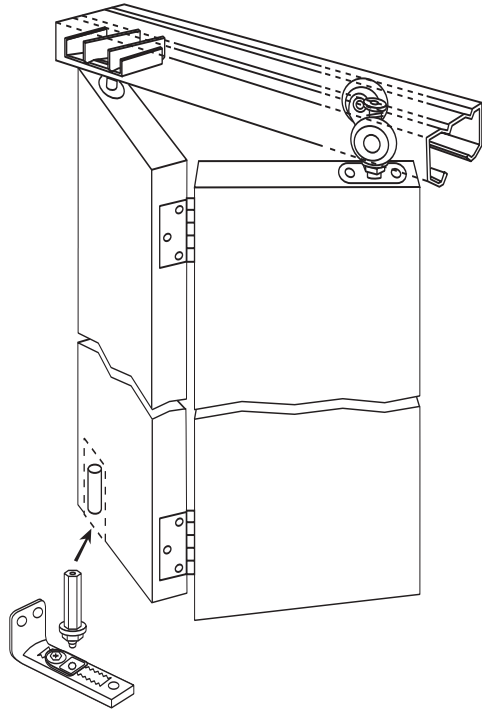

#### Features

- Extruded aluminum track
- Permanently lubricated 2-wheel roller carriage
- Spring loaded top pivot for easy installation
- All metal components galvanized against corrosion
- Quick, easy adjustments after installation
- Smooth, quiet operation

#### ANSI Reference

- BF50 conforms to ANSI A156.14 type D8621, D8642, D8652, D8662

#### Cross Reference

- STANLEY 2600 series • Crowder CF-115
- Grant 1600 • Hager 9570
- Johnson 111 FD • Lawrence HD 620/640
- Sterling 1570



## Sizing Information

#### To determine panel width:

Panel width = known finished opening width divided by number of panels, less 1/4"

#### To determine opening width:

Opening width = known finished panel width plus 1/4", multiplied by number of panels

**Door height** = 2 3/8" less than finished opening height

**Note:** For multi-panel sizing information please contact factory.

## Installation Detail

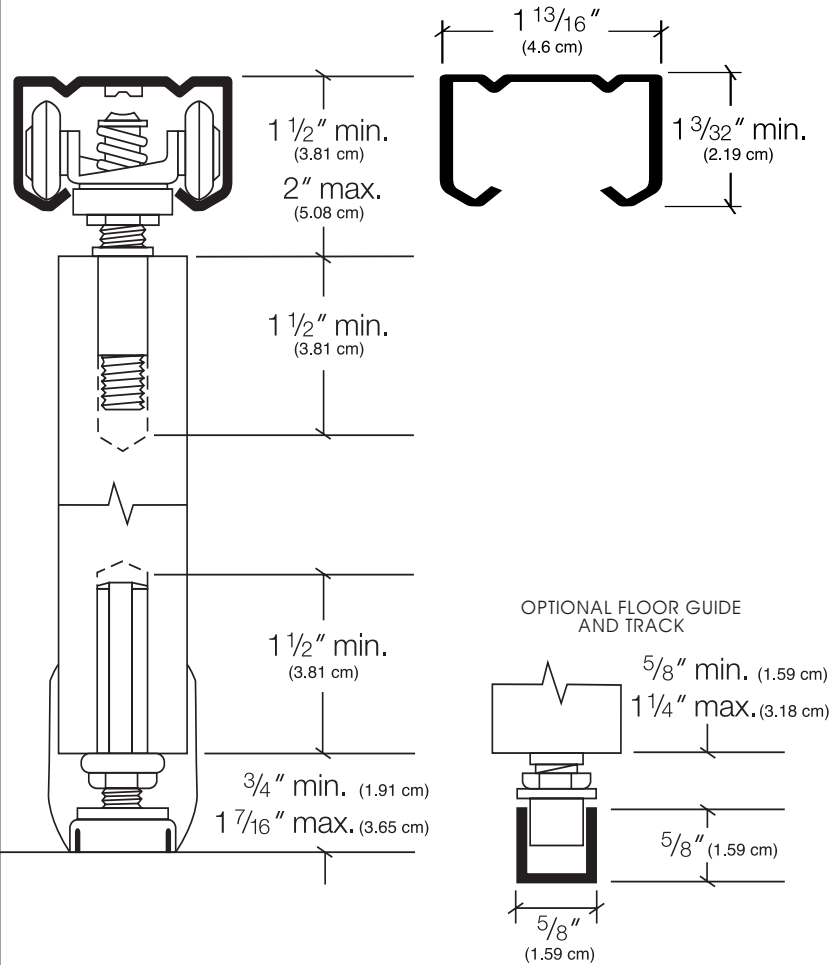

## BF50 – Complete Packaged Sets

Description	Set No.	Case Qty.	Case Weight	EDP Number
2 Door 36" opening	BFC50-00-36	10 sets	16 lbs	40 2293 001
4 Door 48" opening	BFC50-00-48	10 sets	25 lbs	40 2294 001
4 Door 60" opening	BFC50-00-60	10 sets	28 lbs	40 2295 001
4 Door 72" opening	BFC50-00-72	10 sets	30 lbs	40 2296 001
4 Door 96" opening	BFC50-00-96	10 sets	38 lbs	40 2298 001

NOTE: Hinges not included in the set

Track

Track No.	Length	Finish	Case QTY.	Case WEIGHT	EDP Number
BF50-01-48	47 7/8"	ALUMINUM	10	13 LBS	40 2321 001
BF50-01-60	59 7/8"	ALUMINUM	10	16 LBS	40 2322 001
BF50-01-72	71 7/8"	ALUMINUM	10	19 LBS	40 2323 001
BF50-01-96	96"	ALUMINUM	10	24 LBS	40 2324 001
BF50-01-120	120"	ALUMINUM	10	32 LBS	40 2326 001
BF50-01-144	144"	ALUMINUM	10	36 LBS	40 2327 001
BF50-01-192	192"	ALUMINUM	10	52 LBS	40 2328 001

Packaged Set Components

Aluminum Track EDP No.

**BF50-01-XX** \*\* 

Pivot Bracket Case Qty. EDP No.

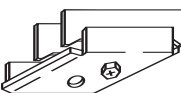
**BF50-11** 200 ea. 40 2304 001  
Adjustable with wrench or screwdriver 

Snugger

**BF50-22** 100 ea. 40 2306 001 

Hanger

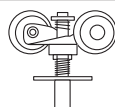
**BF50-41** 10 ea. 40 2303 001   
Two-wheel hanger with guide wheel

**BF50-34** 200 ea. 52 2272 001  
Top Pivot 

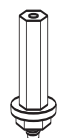
**BF50-33** 200 ea. 52 2276 001  
Bottom Pivot   
Top Pivot Bottom Pivot

Jamb Bracket with Pivot Block

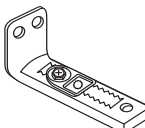
**BF50-81** - 3/4" screws 200 ea. 52 2252 001   
Easy horizontal adjustment

Aligners

**BF50-72** 100 pr. 52 2224 001   
For use in four door installations

Adjusting Wrench

**BP250-99** 400 ea. 52 2232 001 

Knobs

**BF50-62** - Wood 100 ea. 52 1280 001   
Wood

Accessories & Options

Hinges Case Qty. EDP No.

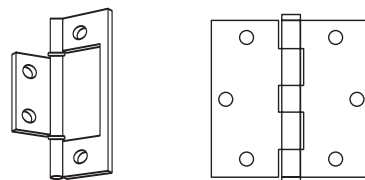

Jamb Brackets

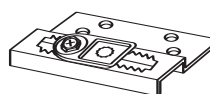
**BF50-83** 200 ea. 52 2264 001  
Floor Bracket for slab floor installations 

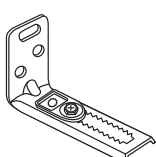
**BF50-84** 200 ea. 52 3236 001  
3/4" flat head screws Heavy Duty Jamb Bracket for mounting above floor 

Floor Guide

**BF125-71** 10 ea. 40 2309 001   
Adjustable high performance, lubricated, thermoplastic guide, 7/16" diameter shank  
For use with BF125-91 Track

Floor Guide Track

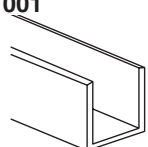
**BF125-91** 10 ea. 40 2310 001   
5/8" x 5/8" x 8' Aluminum

Knobs

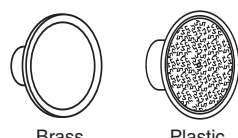
**BF50-61** Plastic 100 ea. 52 1244 001  
**BF50-65** Brass 400 ea. 52 1236 001   
Brass Plastic

Hardware Set

**BF50-HDW** 10 sets 40 2308 001  
Set includes 1 BF50-11 pivot bracket, 1 BF50-81 jamb bracket, 1 BF50-34 top pivot, 1 BF50-33 bottom pivot, 1 BF50-25 snugger accordion, 1 BF250-99 wrench, screws and instructions

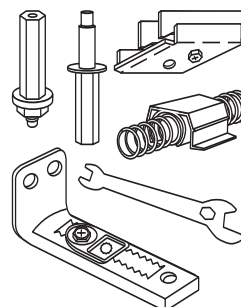

# BiFold Hardware



## BF125N

### 125 lb. Panel Bifold

For installation of 2 panels weighing up to 125 lbs. each or multi-panels weighing up to 75 lbs. each, 1 1/8" to 1 3/4" thick. For thicker panels, consult factory.

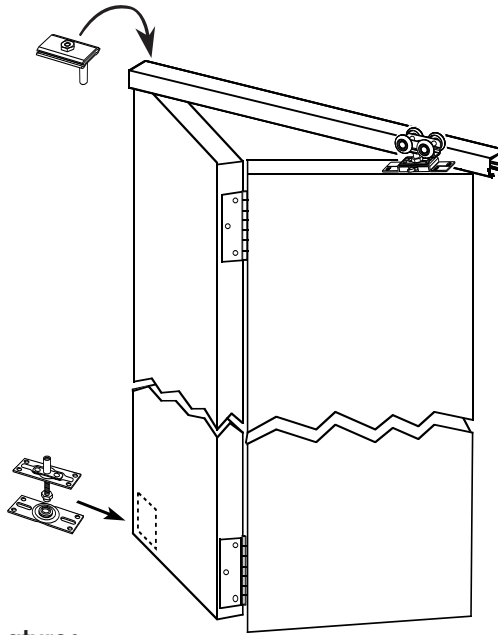

#### Features

- Large ball bearing wheels provide smooth action
- Easy-to-install snap-in feature makes hangers a "snap" to install
- Durable V-groove aluminum track provides smooth, quiet operation
- All metal components zinc plated to guard against corrosion
- Heavy duty pivot set designed for durability and aesthetics

#### ANSI Reference

- BF125N conforms to ANSI A156.14 type D8621, D8641, D8651, D8661

#### Cross Reference

- STANLEY 2700 series • Cox 42-200 • Grant 1260
- Hager 9870 • Johnson 200 FD/RD
- Lawrence 570 Track w/ED 620/640
- Sterling 1870

## Sizing Information

#### To determine panel width:

Panel width = known finished opening width divided by number of panels, less 1/4"

#### To determine opening width:

Opening width = known finished panel width plus 1/4", multiplied by number of panels

**Door height** = 2 3/4" less than finished opening height

**Note:** For multi-panel sizing information please contact factory.

## Installation Detail

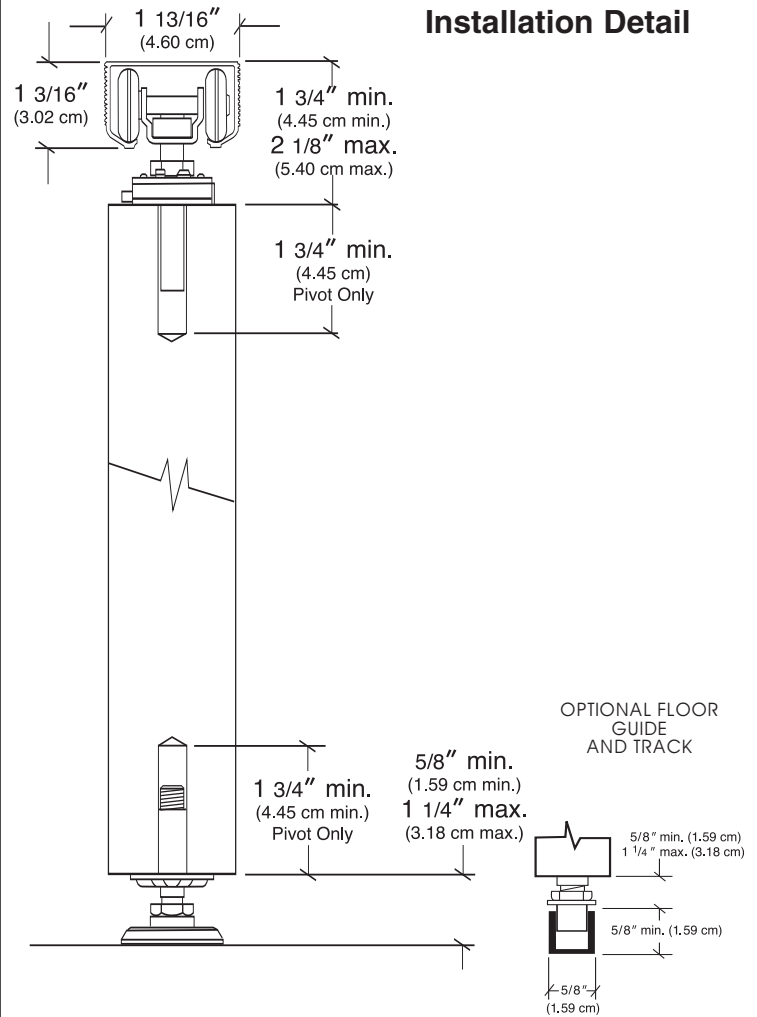

## Complete Packaged Sets

Description	Set No.	Case Qty.	Case Weight	EDP Number
2 Door 30" opening	BF125N-00-30	6 sets	26 lbs	40 5225
2 Door 36" opening	BF125N-00-36	6 sets	26 lbs	40 5232
2 Door 48" opening	BF125N-02-48	6 sets	31 lbs	40 5242
4 Door 48" opening	BF125N-04-48	6 sets	46 lbs	40 5244
4 Door 60" opening	BF125N-00-60	6 sets	50 lbs	40 5254
4 Door 72" opening	BF125N-00-72	6 sets	54 lbs	40 5264
4 Door 96" opening	BF125N-00-96	6 sets	60 lbs	40 5284

Track

Track No.	Length	Finish	Case QTY.	Case Weight	EDP Number
BF125N-01-48	48"	ALUMINUM	10	13 LBS	40 5102 001
BF125N-01-60	60"	ALUMINUM	10	16 LBS	40 5103 001
BF125N-01-72	72"	ALUMINUM	10	29 LBS	40 5104 001
BF125N-01-96	96"	ALUMINUM	10	39 LBS	40 5105 001
BF125N-01-120	120"	ALUMINUM	10	47 LBS	40 5106 001
BF125N-01-144	144"	ALUMINUM	10	57 LBS	40 5107 001
BF125N-01-192	192"	ALUMINUM	10	78 LBS	40 5108 001

Packaged Set Components

Aluminum Track EDP No.

**BF250N-01-XX** \*\*  
V-grooved



Snigger Case Qty. EDP No.

**BF125N-21** 100 ea. 52 4254 001

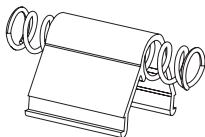

Top & Bottom Pivots Set

**BF125N-31** 10 sets 40 5302 001  
Fits into 1 3/4" deep, 3/8" diameter hole in door

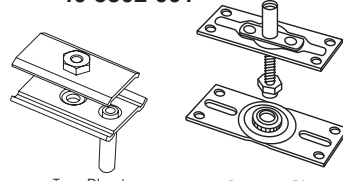

Top Pivot Bottom Pivot

Hangers Case Qty. EDP No.

**BF125N-41** 10 ea. 40 5301 001  
Four large ball bearing wheels, easy installation feature

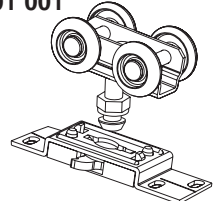

Hinges Case Qty. EDP No.

**741** 50 pks. 08 2100  
US4 Satin Brass Finish  
3 1/2" x 3 1/2", with screws  
.088 Gauge

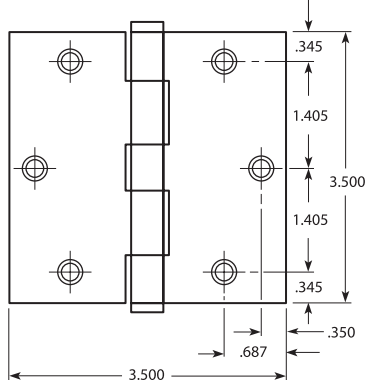

Adjustment Wrench

**BP250-99** 400 ea. 52 2232 001

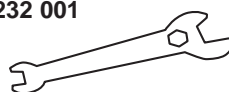

Floor Guide Case Qty. EDP No.

**BF125-71** 10 ea. 40 2309 001  
Adjustable, high performance, lubricated, thermoplastic guide  
7/16" diameter shank  
For use with BF125-91 track

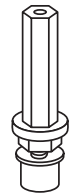

Floor Guide Track

**BF125-91** 10 ea. 40 2310 001  
Aluminum floor guide track  
5/8" x 5/8" x 8'

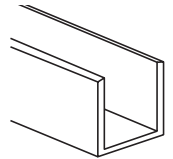

Hinges

**F179/F191**  
**CB179/CB191**  
**FBB179/FBB191**  
**1900R / 1960R**  
**CB1900R / CB1960R**

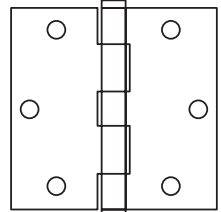

F179 Shown

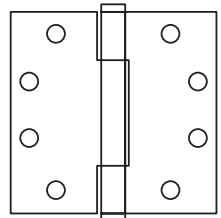

CB1900R Shown

# ByPass Hardware

## BP60 & BPD60

### 60lb. Panel ByPass

For installation of 2 By panels  $3/4"$  to  $1\ 3/8"$  thick, weighing up to 60 lbs. each

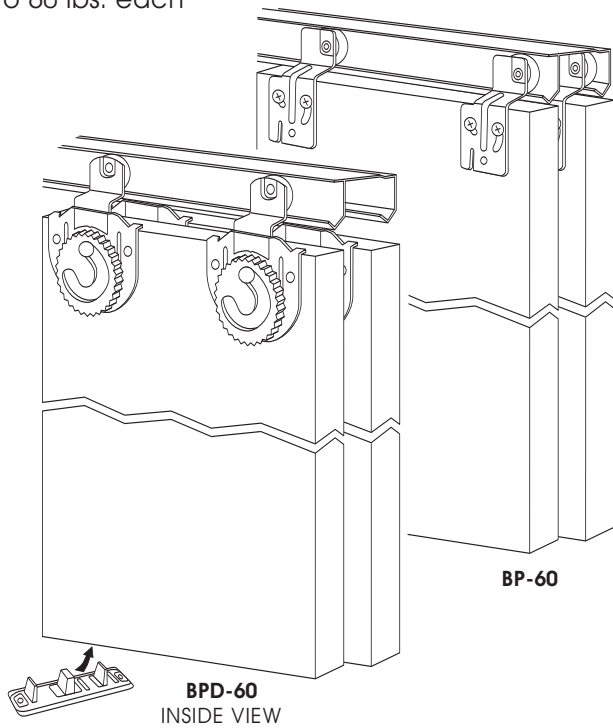

### Track Detail

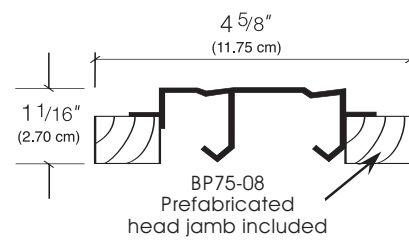
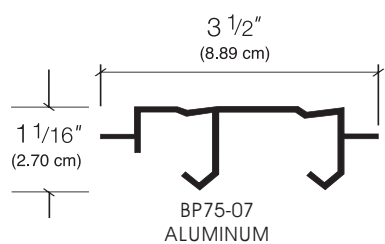
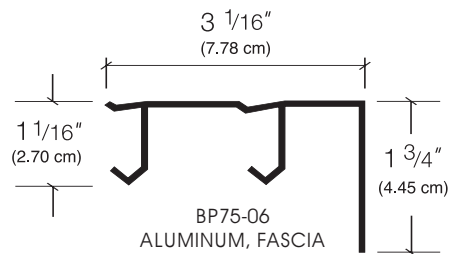
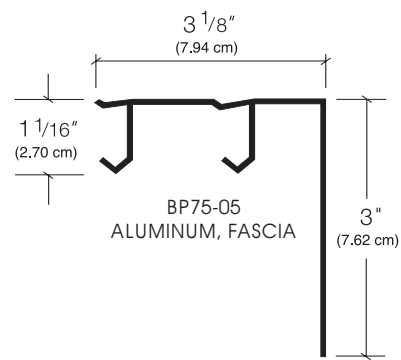
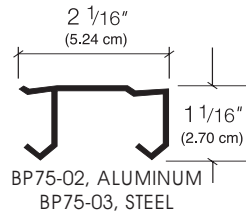
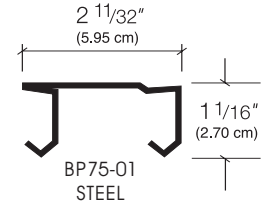

#### Features

- Hangers easy to adjust
- Self-aligning wheel system
- Permanently lubricated thermoplastic wheel
- Supports panels weighing up to 60 lbs
- Vertical adjustments can be made after installation
- Hanger system allows for easy panel removal
- V-groove galvanized steel or aluminum track provides smooth, quiet operation

#### ANSI Reference

- BPC60, BPC60A, BP60, BPD60, BPD60A conform to ANSI A156.14 type D8742; BPC60AF, BPD60AF conform to type D8752

#### Sizing Information

##### To determine panel width:

Panel width = known finished opening width plus 1" per overlap, divided by number of panels

##### To determine opening width:

Opening width = known finished panel width multiplied by number of panels, less 1" per overlap

Door height = 1 3/4" less than finished opening height

#### Installation Detail

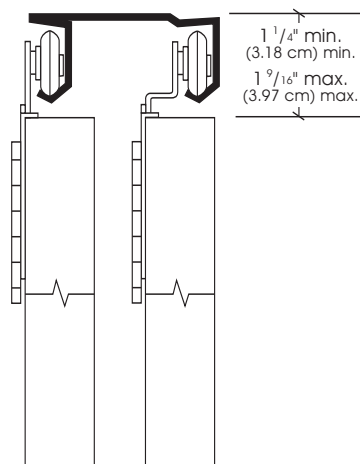

### Complete Packaged Sets Slot Adjust



CONTRACTOR Box Set with steel track BP75-01 For 1 3/8" thick doors only.

Description	Set No.	Case Qty.	Case Weight	EDP Number
2 Door 47" opening	BPC60-00-48	10 sets	26 lbs	40 3006 001
2 Door 59" opening	BPC60-00-60	10 sets	30 lbs	40 3008 001
2 Door 71" opening	BPC60-00-72	10 sets	35 lbs	40 3010 001
2 Door 95" opening	BPC60-00-96	10 sets	45 lbs	40 3012 001

CONTRACTOR Box Set w/aluminum track BP75-02 For 3/4" and 1 3/8" thick doors.

Description	Set No.	Case Qty.	Case Weight	EDP Number
2 Door 47" opening	BPC60A-00-48	10 sets	16 lbs	40 3020 001
2 Door 59" opening	BPC60A-00-60	10 sets	19 lbs	40 3021 001
2 Door 71" opening	BPC60A-00-72	10 sets	22 lbs	40 3022 001

RETAIL Box Set with steel track BP75-03 For 3/4" and 1 3/8" thick doors.

Description	Set No.	Case Qty.	Case Weight	EDP Number
2 Door 47" opening	BP60-00-48	6 sets	20 lbs	40 3040
2 Door 59" opening	BP60-00-60	6 sets	23 lbs	40 3050
2 Door 71" opening	BP60-00-72	6 sets	27 lbs	40 3060
2 Door 95" opening	BP60-00-96	6 sets	35 lbs	40 3080

### Packaged Set Components

Single Wheel Hangers	Case Qty.	EDP No.
<b>BP60-43</b> – 1/4" offset Includes 7 each 5/8" screws	<b>50 per</b>	<b>54 1268 001</b>
<b>BP60-44</b> – 1/4" offset Includes 4 each 5/8" and 3 each 1-1/2" screws	<b>50 per</b>	<b>54 1272 001</b>
<b>BP60-45</b> – 1/2" offset Includes 7 each 5/8" screws	<b>50 per</b>	<b>54 1284 001</b>
<b>BP60-46</b> – 1/2" offset Includes 4 each 5/8" and 3 each 1-1/2" screws	<b>50 per</b>	<b>54 1288 001</b>



### Floor Guide

<b>BP150-71</b> – Zinc / White Adjustable for 3/4" to 1-3/8" thick bypassing doors	<b>50 ea.</b>	<b>54 1008 001</b>
---	---------------	--------------------



### Pulls

<b>BP150-61</b> Bright Brass 3/4" finger pull	<b>200 ea.</b>	<b>52 1224 001</b>
--	----------------	--------------------



### Complete Packaged Sets Dial Adjust



RETAIL Box Set with steel track BP75-03 For 3/4" and 1 3/8" thick doors.

Description	Set No.	Case Qty.	Case Weight	EDP Number
2 Door 47" opening	BPD60-00-48	6 sets	21 lbs	40 3140
2 Door 59" opening	BPD60-00-60	6 sets	25 lbs	40 3150
2 Door 71" opening	BPD60-00-72	6 sets	28 lbs	40 3160
2 Door 95" opening	BPD60-00-96	6 sets	36 lbs	40 3180

RETAIL Box Set with aluminum track BP75-02 For 3/4" and 1 3/8" thick doors.

Description	Set No.	Case Qty.	Case Weight	EDP Number
2 Door 47" opening	BPD60A-00-48	6 sets	16 lbs	40 3240 001
2 Door 59" opening	BPD60A-00-60	6 sets	18 lbs	40 3250 001
2 Door 71" opening	BPD60A-00-72	6 sets	20 lbs	40 3260 001

### Packaged Set Components

Single Wheel Hangers	Case Qty.	EDP No.
<b>BP60-41</b> – 7/16" offset #1 Finger adjustable, side mounted	<b>100 ea.</b>	<b>54 1024 001</b>
<b>BP60-42</b> – 1/8" offset #2 Finger adjustable, side mounted	<b>100 ea.</b>	<b>54 1028 001</b>



### Floor Guide

<b>BP150-71</b> – Zinc / White Adjustable for 3/4" to 1-3/8" thick bypassing doors	<b>50 ea.</b>	<b>54 1008 001</b>
---	---------------	--------------------

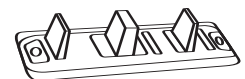

### Pulls

<b>BP150-61</b> Bright Brass 3/4" finger pull	<b>200 ea.</b>	<b>52 1224 001</b>
--	----------------	--------------------



### Track

Track No.	Length	Finish	Case Qty.	Case Weight	EDP Number
BP75-01-48	46 1/2"	STEEL	10	18 LBS	54 1416 001
BP75-01-60	58 1/2"	STEEL	10	24 LBS	54 1420 001
BP75-01-72	70 1/2"	STEEL	10	29 LBS	54 1424 001
BP75-01-96	93 1/2"	STEEL	10	39 LBS	54 1436 001
BP75-01-120	120"	STEEL	10	51 LBS	54 1444 001
BP75-01-144	144"	STEEL	10	54 LBS	54 1448 001
BP75-02-48	46 3/8"	ALUMINUM	10	12 LBS	54 1232 001
BP75-02-60	58 3/8"	ALUMINUM	10	15 LBS	54 1236 001
BP75-02-72	70 3/8"	ALUMINUM	10	17 LBS	54 1240 001
BP75-02-96	3 3/8"	ALUMINUM	10	25 LBS	54 1248 001
BP75-02-144	144"	ALUMINUM	10	35 LBS	54 1264 001
BP75-03-48	46 3/8"	STEEL	10	18 LBS	59 3096 001
BP75-03-60	58 3/8"	STEEL	10	24 LBS	59 3100 001
BP75-03-72	70 3/8"	STEEL	10	29 LBS	59 3104 001

Track No.	Length	Finish	Case Qty.	Case Weight	EDP Number
BP75-05-48	46 7/8"	ALUMINUM	10	23 LBS	54 1456 001
BP75-05-60	58 7/8"	ALUMINUM	10	28 LBS	54 1460 001
BP75-05-72	70 7/8"	ALUMINUM	10	34 LBS	54 1464 001
BP75-05-96	94 7/8"	ALUMINUM	10	46 LBS	54 1472 001
BP75-05-120	120"	ALUMINUM	10	59 LBS	54 1476 001
BP75-06-48	48"	ALUMINUM	10	18 LBS	54 1488 001
BP75-06-60	60"	ALUMINUM	10	22 LBS	54 1492 001
BP75-06-72	72"	ALUMINUM	10	25 LBS	54 1496 001
BP75-06-96	96"	ALUMINUM	10	39 LBS	54 1504 001
BP75-06-144	144"	ALUMINUM	10	54 LBS	54 1512 001
BP75-07-48	46 7/8"	ALUMINUM	10	23 LBS	54 1368 001
BP75-07-60	58 7/8"	ALUMINUM	10	28 LBS	54 1372 001
BP75-07-72	70 7/8"	ALUMINUM	10	34 LBS	54 1376 001
BP75-08-48	46 7/8"	ALUMINUM	10	23 LBS	54 1384 001
BP75-08-60	58 7/8"	ALUMINUM	10	28 LBS	54 1388 001
BP75-08-72	70 7/8"	ALUMINUM	10	34 LBS	54 1392 001

See next page for accessories and options

# ByPass Hardware

## BP60 & BPD60

Twin Wheel Hangers Case Qty. EDP No.

**BP75-43**— 1/4" offset **50 pr.** **54 1296 001**  
Twin wheel hanger, side mounted

**BP75-45**— 1/2" offset **50 pr.** **54 1304 001**  
Twin wheel hanger, side mounted  
For doors up to 75 lbs. each.

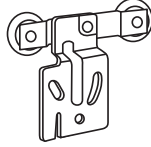

### Angle Stop

**BP250-75**— Zinc **100 ea.** **54 1004 001**  
Attaches to back of one panel to prevent panels from crossing



### Center Stop

**BP75-76** **40 3998 001**  
Attaches to track to limit door travel

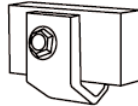

## Accessories & Options

### Pulls

**BP250-61**— Bright Brass **20 ea.** **52 1228 001**  
2-1/8" Flush Pull

**BP250-62**— Antique Brass **100 ea.** **52 1240 001**  
2-1/8" Flush Pull



### Floor Guides

**BP150-72**— White **100 ea.** **54 1020 001**  
Floor Guide, plastic, for 1-3/8" thick doors

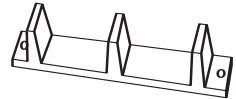

**BP150-73**— White **100 ea.** **54 1000 001**  
Floor Guide, plastic, one pair/door

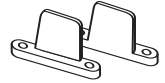

### Carpet Riser

**BP150-74**— Zinc **50 ea.** **54 1016 001**  
Carpet Riser provides 1/2" rise for Floor Guide BP150-71 and BP150-72



**BP150-75**— Zinc/White **50 ea.** **54 1012 001**  
(BP150-71 50 per box bulk pack)  
For 3/4" to 1 3/8" doors.





EDP No.	54 1292 001 8902-BX BP60-HDW-5	54 1104 001 8400-BX1 BP60-HDW-8	54 1280 001 8901-BX BP60-HDW-4	54 1252 001 8900-BX BP60-HDW-3	54 1116 001 8401-BX BP60-HDW-2	54 1100 001 8400-BX BP60-HDW	54 1312 001 8906-X BP75-HDW-2	54 1036 001 8100-BX BP75-HDW-1	
<b>Class No.</b>	<b>Part Description</b>								
BP60-46	4	4	-	2	4	4	-	-	
BP60-44	-	-	4	2	-	-	-	-	
BP75-45	-	-	-	-	-	-	4	2	
BP75-43	-	-	-	-	-	-	-	2	
BP150-72	1	-	-	-	-	-	1	-	
BP150-71	-	1	1	1	1	1	-	1	
BP250-61	2	-	-	-	2	-	2	-	
BP150-61	-	2	-	-	-	-	-	-	
BP150-62	-	-	2	2	-	2	-	2	
	#8 x 5/8" Pan Head Screw	10	10	16	16	16	16	10	16
	#8 x 1 1/2" Pan Head Screw	6	10	-	10	10	10	6	-
	Instruction Sheet	1	1	-	1	1	1	1	1
	Instruction Sheet	-	-	1	-	-	-	-	-
	Carton Qty.	10	10	10	10	10	10	10	10

How to Determine Hanger Combinations

3/4" Panels

TRACK	SLOT ADJUST HANGERS SINGLE WHEEL FRONT/REAR	SLOT ADJUST HANGERS TWIN WHEEL FRONT/REAR	DIAL ADJUST HANGERS FRONT/REAR
BP75-02	BP60-45/BP60-44	BP75-45/BP75-43	BP60-41/BP60-42
BP75-03	BP60-45/BP60-44	BP75-45/BP75-43	BP60-41/BP60-42

1" – 1 1/8" Panels

BP75-01	BP60-45/BP60-44	BP75-45/BP75-43	BP60-41/BP60-42
BP75-02	BP60-45/BP60-45	BP75-45/BP75-45	BP60-41/BP60-41
BP75-03	BP60-45/BP60-45	BP75-45/BP75-45	BP60-41/BP60-41
BP75-05	BP60-45/BP60-44	BP75-45/BP75-43	BP60-41/BP60-42
BP75-06	BP60-45/BP60-44	BP75-45/BP75-43	BP60-41/BP60-42
BP75-07	BP60-45/BP60-44	BP75-45/BP75-43	-
BP75-08	BP60-45/BP60-44	BP75-45/BP75-43	-

1 3/8" Panels

BP75-01	BP60-45/BP60-45	BP75-45/BP75-45	BP60-41/BP60-41
BP75-02	BP60-43/BP60-45	BP75-43/BP75-45	BP60-42/BP60-41
BP75-03	BP60-43/BP60-45	BP75-43/BP75-45	BP60-42/BP60-41
BP75-05	BP60-45/BP60-45	BP75-45/BP75-45	BP60-41/BP60-41
BP75-06	BP60-45/BP60-45	BP75-45/BP75-45	BP60-41/BP60-41
BP75-07	BP60-44/BP60-44	BP75-43/BP75-43	-
BP75-08	BP60-44/BP60-44	-	-

STANLEY ARCHITECTURAL HARDWARE

# ByPass Hardware

## BP150N & BP250N

For installation of 2 bypassing doors, with 1 3/8" to 1 3/4" thick panels

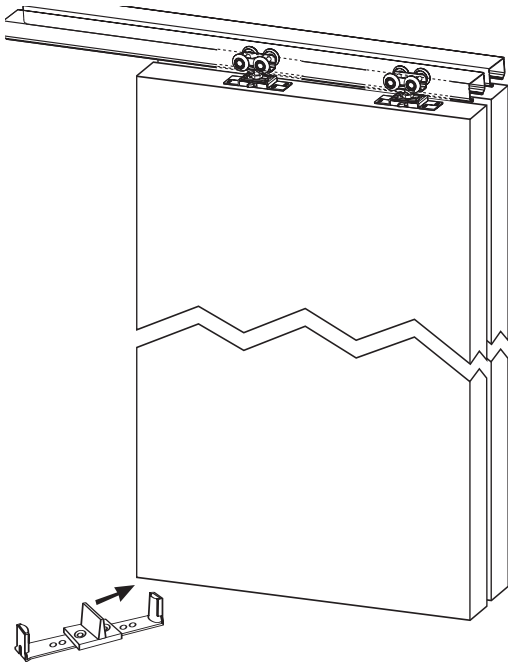

### Features

- BP150N supports panels weighing up to 150 lbs
- BP250N supports panels weighing up to 250 lbs
- Large 1" wheels provide smooth action
- Easy-to-install snap-in feature makes hangers a "snap" to install. Vertical adjustments can be made after installation.
- Durable V-groove aluminum track provides smooth, quiet operation
- Track spacer allows for easy installation of 1 3/4" bypass and tri-pass doors

### ANSI Reference

- BPC150N and BPC250N conform to ANSI A156.14 type D8731
- Above with Fascia conform to ANSI A156.14 type D8751

### Cross Reference—BP150N

- STANLEY 1700 series • Cox 15 • Crowder C-500
- Grant 7000 • Hager 9602 • Sterling 1754
- Lawrence 581 Track w/HD520

### Cross Reference—BP250N

- STANLEY-57/58 • Crowder C-103-4
- Grant 1200 • Hager 9875
- Lawrence - F571/ED520 • Sterling 1876



## 150 lb. & 250 lb. Panel ByPass

### Sizing Information

#### To determine panel width:

Panel width = known finished opening width plus 1" per overlap divided by number of panels

#### To determine opening width:

Opening width = known finished panel width multiplied by number of panels, less 1" per overlap

Door height = 2 5/8" less than finished opening height

### Installation Detail

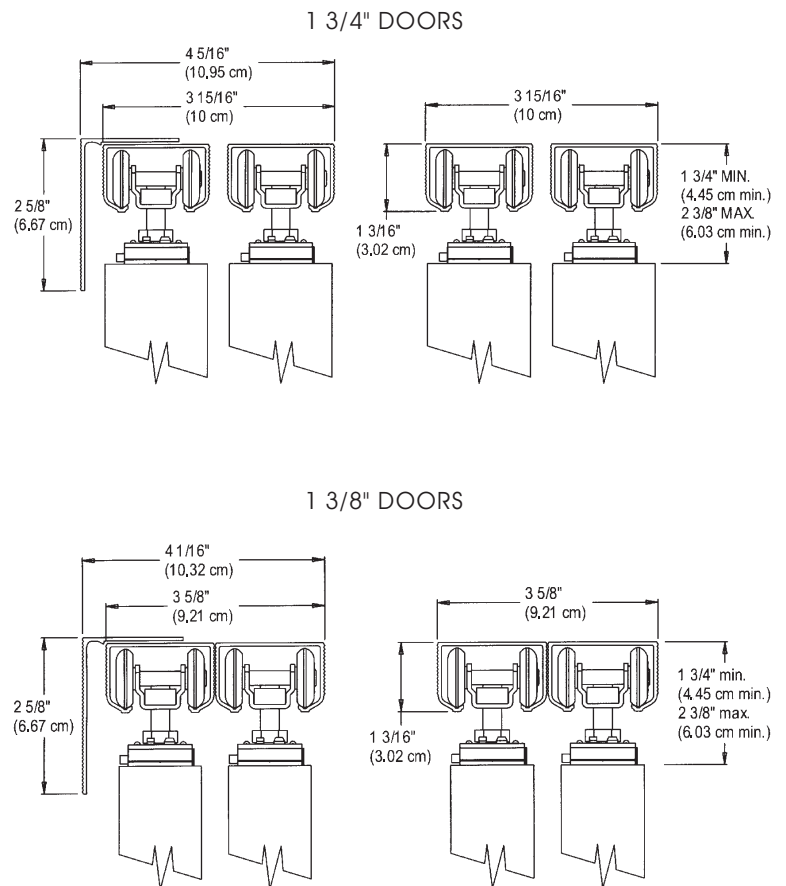

## Complete Packaged Sets

### 150 lb.

CONTRACTOR Box Set with BP150N – 41 Hangers

Description	Set No.	Case Qty.	Case Weight	EDP Number
2 Door 48" opening	BPC150N-00-48	6 sets	22 lbs	40 5664
2 Door 60" opening	BPC150N-00-60	6 sets	25 lbs	40 5665
2 Door 72" opening	BPC150N-00-72	6 sets	28 lbs	40 5666
2 Door 96" opening	BPC150N-00-96	6 sets	34 lbs	40 5668

### 250 lb.

CONTRACTOR Box Set with BP250N – 41 Hangers

Description	Set No.	Case Qty.	Case Weight	EDP Number
2 Door 60" opening	BPC250N-00-60	6 sets	48 lbs	40 5750
2 Door 72" opening	BPC250N-00-72	6 sets	53 lbs	40 5760
2 Door 96" opening	BPC250N-00-96	6 sets	63 lbs	40 5780

**BP150N & BP250N**

**Track**

Track No.	Length	Finish	Case QTY.	Case Weight	EDP Number
BP250N-01-48	48"	ALUMINUM	10	13 LBS	40 5102 001
BP250N-01-60	60"	ALUMINUM	10	16 LBS	40 5103 001
BP250N-01-72	72"	ALUMINUM	10	29 LBS	40 5104 001
BP250N-01-96	96"	ALUMINUM	10	39 LBS	40 5105 001
BP250N-01-120	120"	ALUMINUM	10	47 LBS	40 5106 001
BP250N-01-144	144"	ALUMINUM	10	57 LBS	40 5107 001
BP250N-01-192	192"	ALUMINUM	10	78 LBS	40 5108 001

**Fascia**

Track No.	Length	Finish	Case QTY.	Case Weight	EDP Number
BP250N-02-48	48"	ALUMINUM	10	24 LBS	40 5200 001
BP250N-02-60	60"	ALUMINUM	10	30 LBS	40 5201 001
BP250N-02-72	72"	ALUMINUM	10	35 LBS	40 5202 001
BP250N-02-96	96"	ALUMINUM	10	35 LBS	40 5203 001
BP250N-02-120	120"	ALUMINUM	10	35 LBS	40 5204 001

**Packaged Set Components**

Aluminum Track EDP No.

---

**BP250N-01-XX** \*\*

Track Spacer Case Qty. EDP No.

---

**BP250N-00** **10 sets** **40 5306 001**

For 1 3/4" doors

Hanger Case Qty. EDP No.

---

**BP150N-41** **20 pr.** **40 5304 001**

Four large wheels, easy installation feature  
Packaged with BP150N-00

Hanger Case Qty. EDP No.

---

**BP250N-41** **5 pr.** **40 5305 001**

Four large, ball-bearing wheels, easy installation feature  
Packaged with BP250N-00

Floor Guide Case Qty. EDP No.

---

**BP250N-71** **50 ea.** **40 3534 001**

Adjustable for 1 3/8" to 1 3/4" thick bypassing doors

Adjusting Wrench Case Qty. EDP No.

---

**BP250-99** **400 ea.** **52 2232 001**

**Accessories & Options**

Aluminum Fascia EDP No.

---

**BP250N-02-XX** \*\*

Angle Stop Case Qty. EDP No.

---

**BP250-75 – Zinc** **100 ea.** **54 1004 001**

Attaches to back of one panel to prevent panels from crossing

Center Stop Case Qty. EDP No.

---

**BP250-77 – Zinc** **20 ea.** **40 0004 001**

Attaches to track to limit panel travel

Pulls Case Qty. EDP No.

---

**BP150-61 – Bright Brass** **200 ea.** **52 1224 001**

3/4" Finger Pull

**BP250-61 – Bright Brass** **20 ea.** **52 1228 001**

2 1/8" Flush Pull

**BP250-62 – Antique Brass** **100 ea.** **52 1240 001**

2 1/8" Flush Pull

Hanger Sets Case Qty. EDP No.

---

**BP150N-HDW** **10 sets** **44 5860 001**

Set contains (2) BP250N-43 hanger plates, (2) BP150N-41 ball bearing hangers, (1) BP250-99 wrench and (1) BP250-71 floor guide. (For doors weighing up to 150 lbs. each)

**BP250N-HDW** **10 sets** **40 5790 001**

Set contains (2) BP250N-43 hanger plates, (2) BP250N-41 ball bearing hangers, (1) BP250-99 wrench and (1) BP250-71 floor guide. (For doors weighing up to 250 lbs. each)

Floor Guides Case Qty. EDP No.

---

**BP150-71 – Zinc/White** **50 ea.** **54 1008 001**

Adjustable for 3/4" to 1 3/8" thick bypassing doors

**BP150-75 – Zinc/White** **50 ea.** **54 1012 001**

Adjustable for 3/4" to 1 3/8" thick bypassing doors

**BP150-72 – White** **100 ea.** **54 1020 001**

Floor Guide, plastic, for 1 3/8" thick doors

**BP150-73 – White** **100 ea.** **54 1000 001**

Floor Guide, plastic, one pair/door

Carpet Riser Case Qty. EDP No.

---

**BP150-74 – Zinc** **50 ea.** **54 1016 001**

Carpet Riser provides 1/2" rise for Floor Guides BP150-71 and BP150-72

# Pocket Door Hardware

## PD75

### 75 lb. Panel – Pocket Door

For installation of pocket or bi-parting doors, with 3/4" to 1 3/4" thick panels weighing up to 75 lbs. each.

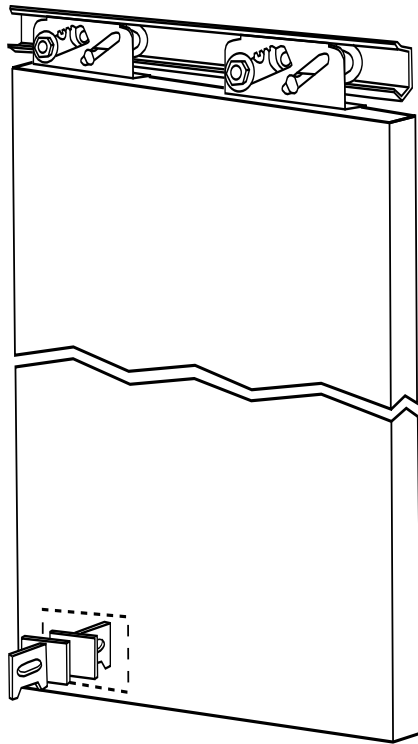

### Installation Detail

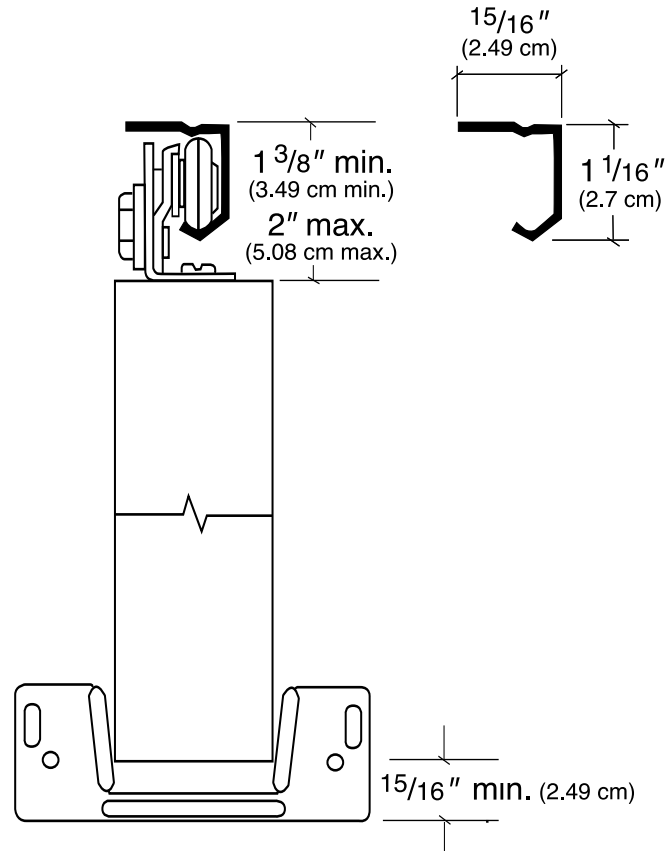

#### Features

- Self-aligning wheel system
- Permanently lubricated 2-wheel hangers
- Supports panels weighing up to 75 lbs
- Easy adjustment after installation
- Roll-formed galvanized jump proof steel track



#### ANSI Reference

- PD75 conforms to ANSI A156.14 types D8691, D8721

#### Cross Reference

- STANLEY 84/85 series • Crowder C-300/350
- Grant 5075 • Johnson 2800

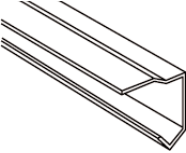
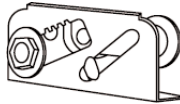
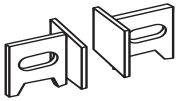
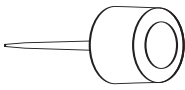
### Packaged Set Components

	Single Track	EDP No.
	<b>PD75-01</b> V-groove jump proof track <b>Not available separately</b>	**
	<b>BP75-41</b> <b>Not available separately</b>	**
	<b>PD250-71</b> Adjustable to center door in pocket	40 3530 001
	<b>PD250-77</b> Stop and nail	40 3969 001
	<b>BP250-99</b>	52 2232 001

### Complete Packaged Sets

RETAIL Box Set with steel track PD75-01

Description	Set No.	Case Qty.	Case Weight	EDP Number
1 Door 36" opening	PD75-00-36	6 sets	18 lbs	40 3903

**PD150N**

**150 lb. Panel – Pocket Door**

For installation of pocket or bi-parting doors, with 1" to 1 3/4" thick panels weighing up to 150 lbs. each.

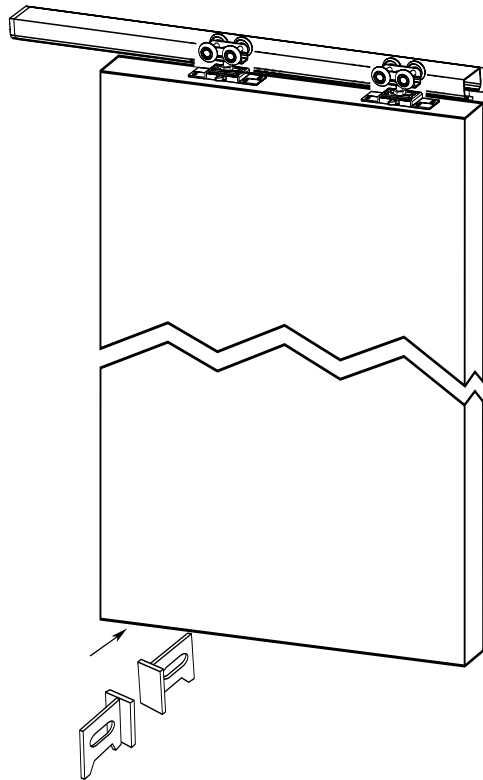

**Features**

- Four large 1" wheels for easy rolling action
- Easy-to-install feature makes installation a "snap"
- Supports panels weighing up to 150 lbs
- Easy adjustment after installation
- Cut marks on header make for easy sizing
- V-groove jump proof track

**ANSI Reference**

- PD150N conforms to ANSI A156.14 type D8681, D8711

**Cross Reference**

- STANLEY 1750 • Cox 15-200 • Crowder C-411
- Grant 5150 • Hager 9601w/9606 • Sterling 1601

**Complete Packaged Sets**



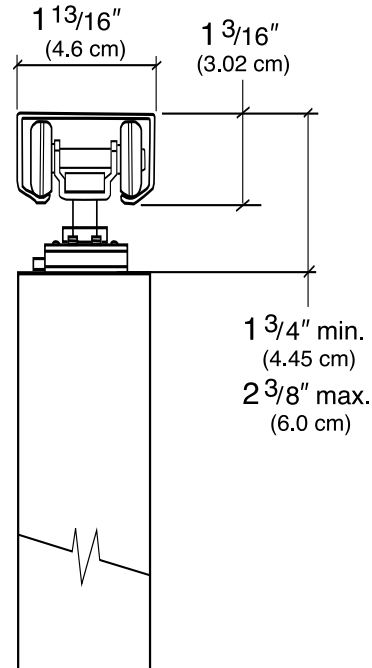

CONTRACTOR Box Set with aluminum track PD250N-01

Description	Set No.	Case Qty.	Case Weight	EDP Number
36" opening	PDC150N-00-36	6 sets	17 lbs	40 5843
48" opening	PDC150N-00-48	6 sets	21 lbs	40 5844

**Installation Detail**

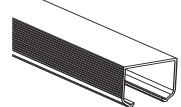
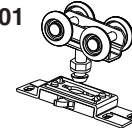

**Packaged Set Components**

Aluminum	EDP No.
<b>PD250N-01-xx</b> V-groove jump proof track	** 
Hanger	
<b>BP150N-41</b>	40 5304 001 
Bottom Guide	
<b>PD250-71</b> Adjustable to center door in pocket	40 3530 001 
Bumper Stop	
<b>PD250-77</b> Stop and nail	40 3969 001 
Adjusting Wrench	
<b>BP250-99</b>	52 2232 001 

**Replacement Hardware**

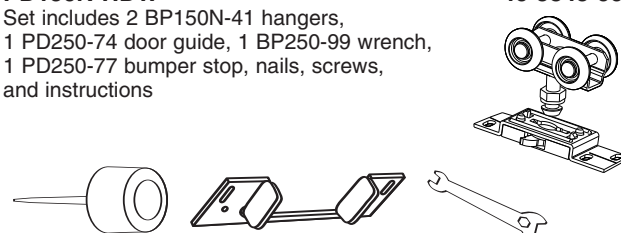
Hardware Set	EDP No.
<b>PD150N-HDW</b> Set includes 2 BP150N-41 hangers, 1 PD250-74 door guide, 1 BP250-99 wrench, 1 PD250-77 bumper stop, nails, screws, and instructions	40 5845 001 

See page 23 for Accessories and Options

# Pocket Door Hardware

## PDF150N & PDF250N

### 150lbs & 250lbs Panel Pocket Frames

**PDF150N** - For installation of pocket or bi-parting doors up to 3' wide and up to 8' high, weighing up to 150 lbs each

**PDF250N** - For installation of pocket or bi-parting doors up to 4' wide and up to 8' high, weighing up to 250 lbs each

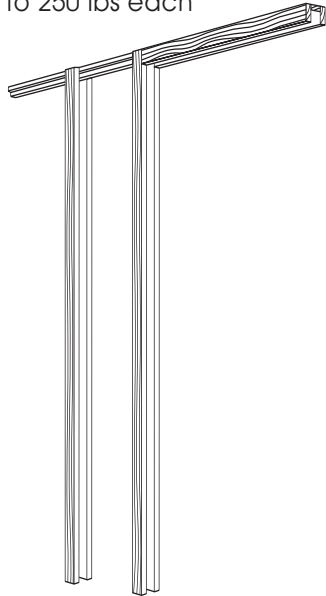

#### Features

- Steel wrap around stiffener reinforced split jambs
- Four large 1" wheels for easy rolling action
- PDF150N Supports panels weighing up to 150 lbs
- PDF250N Supports panels weighing up to 250 lbs
- Easy-to-install feature makes installation a "snap"
- V-groove jump proof track
- Cut marks on header for easy sizing

#### ANSI Reference

All conform to ANSI A156.14 type D8671, D8701

#### Cross Reference

- PDF150N** • Crowder Crowderframe • Hager 9629
- Sterling 1630 BB
- PDF250N** • Hager 9850 • Lawrence PF619
- Sterling 1840

### PDF150N – Complete Packaged Sets

CONTRACTOR Box Set

Description	Set No.	Case Qty.	Case Weight	EDP Number
3' x 6'8" opening	PDFC150N-00-68	1 set	26 lbs	40 3925
3' x 7'0" opening	PDFC150N-00-70	1 set	31 lbs	40 5940 001
3' x 8'0" opening	PDFC150N-00-80	1 set	35 lbs	40 5942 001

### PDF250N – Complete Packaged Sets

CONTRACTOR Box Set

Description	Set No.	Case Qty.	Case Weight	EDP Number
4' x 8'0" opening	PDFC250N-00	1 set	39 lbs	40 5950 001



## Sizing Information

### Finished Rough Opening

**Opening Width** = Door width multiplied by 2, add 1 1/4"  
**For Bi Part** – Sum of 2 Doors, multiplied by 2, add 1 1/4"

PDF150N kits are sized for 3'0" door and PDF250N kits are sized for 4'0" door. Both can be cut down to accommodate smaller door widths.

Kits are sized for 6'8", 7'0" or 8'0" door height and can be cut shorter at installation

### Rough Opening Height for Single Doors

For bi-parting application refer to installation instructions

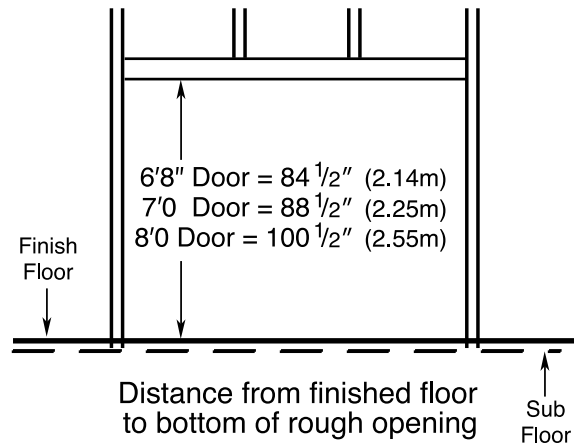

## Installation Detail

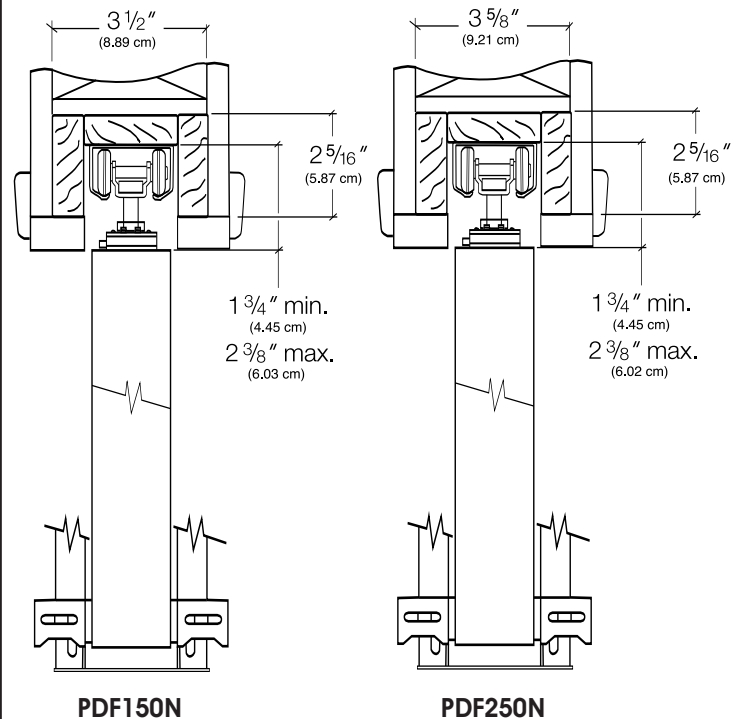

**PD150N – Packaged Set Components**

Aluminum Header Track EDP No.

**PD250N-01** \*\*  
Not available separately



Hanger Case Qty. EDP No.

**BP150N-41** 100 ea. **40 5304 001**  
Four large wheels, easy installation feature

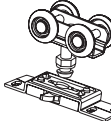

Door Guide

**PD250-71** 100 ea. **40 3530 001**  
Adjustable to center door in pocket

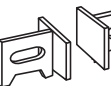

Bumper Stop

**PD250-77** 100 ea. **40 3969 001**  
Stop and nail

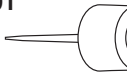

Base Plates

**PDF150-75**  
Not available separately

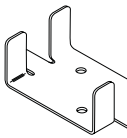

Adjusting Wrench

**BP250N-99** 400 ea. **52 2232 001**



End Bracket

**PDF150-05**  
Not available separately



Split Stud Uprights

**PDF150-51**  
Not available separately



**PD250N – Packaged Set Components**

Aluminum Header Track EDP No.

**PDF250N-01** \*\*  
Not available separately



Hanger Case Qty. EDP No.

**BP250N-41** 50 pr. **40 5305 001**  
Four large ball-bearing wheels, easy installation feature

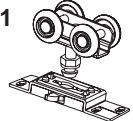

Door Guide

**PD250-71** 100 ea. **40 3530 001**  
Adjustable to center door in pocket



Bumper Stop

**PD250-77** 100 ea. **40 3969 001**  
Stop and nail



Base Plates

**PDF250-75**  
Not available separately

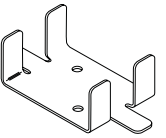

Adjusting Wrench

**BP250-99** 400 ea. **52 2232 001**



End Bracket

**PDF250-05**  
Not available separately



Split Stud Uprights

**PDF250-51**  
Not available separately



**Accessories & Options**

Pulls (for use on 1 3/8" thick doors) EDP No.

**PD150-61**  
2 3/4" Pull brass **40 4000**



**PD150-62** (for use on 1 3/8" thick doors)  
2 3/4" Privacy lock, brass **40 4010 001**  
2 3/4" Privacy lock, antique brass **40 4012 700**



Pulls (for use on 1 3/8" to 1 3/4" thick doors) EDP No.

**PD250-61** brass **40 4030**  
3 3/4" Pull



**PD250-62** (for use on 1 3/8" to 1 3/4" thick doors)  
brass **40 4040**  
3 3/4" Privacy lock,



**PD250-63** brass **52 1272 001**  
Edge Pull



**PD250-64** brass **52 1276 001**  
2 3/4" x 1 5/16" x 3/8"  
Flush Pull



**PD250-05** **40 5960 001**  
Bi-parting bracket with center stops



Jamb Stiffener EDP No.

**PD250-95-81** **40 3963 001**  
81 3/4" Slotted Steel Stiffener



**PD250-95-97** **40 3965 001**  
97 3/4" Slotted Steel Stiffener



**PD250-96** **40 3966 001**  
81 3/4" Plain Steel Stiffener



Center Stop EDP No.

**BP250-77** Zinc **40 0004 001**  
Attaches to track to limit panel travel



Door Guide EDP No.

**PD250-74** **40 3993 001**  
Adjusts to center door in pocket for 1 3/8" doors



**PD250-72** **40 3997 001**  
Adjusts to center door in pocket for 1 3/4" doors



Jamb Spacer EDP No.

**BP250-98** **40 3996 001**

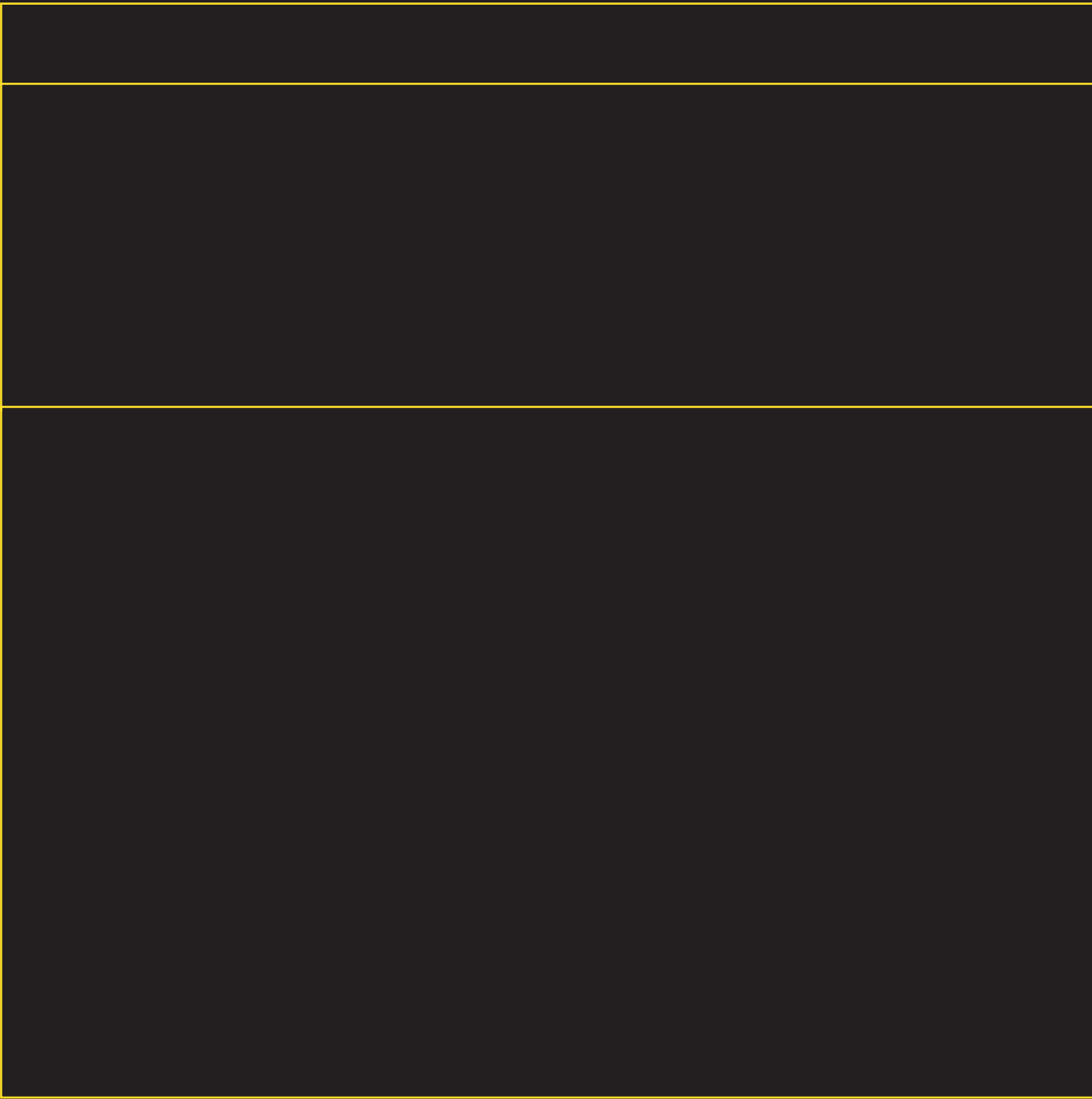

For more information on Stanley Security Solutions' products, services, and office locations visit our web site at [www.stanleysecuritysolutions.com](http://www.stanleysecuritysolutions.com)

Product information contained in this catalog has been compiled and presented with as much care and completeness as is reasonably possible. Errors or mistakes may be present, and in many cases, reliance has been placed on information supplied by other manufacturers which may be in error or which may be subject to changes or modifications by the manufacturer without notice and without obligation. Therefore, no guarantee can be made or should be assumed or implied with regards to product information contained in this catalog.



**Security Solutions**

**Stanley Security Solutions, Inc.**

6161 E. 75th Street Indianapolis, Indiana 46250

[www.stanleysecuritysolutions.com](http://www.stanleysecuritysolutions.com)

© 2007 Stanley Security Solutions, Inc. and Stanley Logistics

10M R708  
SAH017