

SPEAKMAN CHELSEA™

Centerset Faucet SB-1711

SPECIFICATION

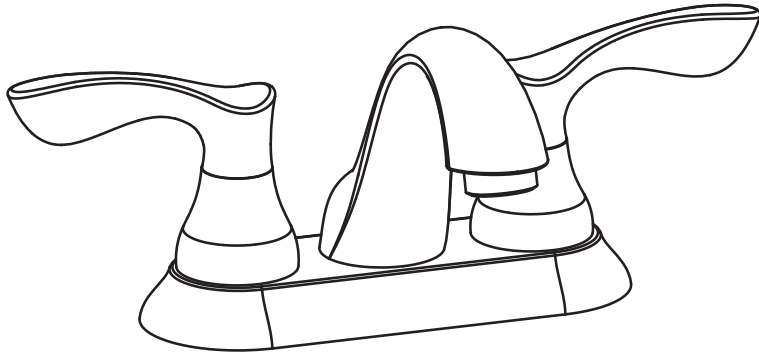

FEATURES:

- Lead-free brass construction
- ¼ turn ceramic cartridges
- Lever handles
- Transitional styling
- 1.5 gpm (5.7 L/min) flow rate
- Includes drain assembly

COMPLIANCE:

- Certified to ASME A112.18.1/
CSA B125.1 and NSF 61 standards
- ADA compliant
- CA AB 1953 certified
- WaterSense certified



AVAILABLE FINISHES:

ADD SUFFIX TO MODEL #

- Polished Chrome (standard)
- Brushed Nickel

□ -BN

WARRANTY:

- 1 year limited

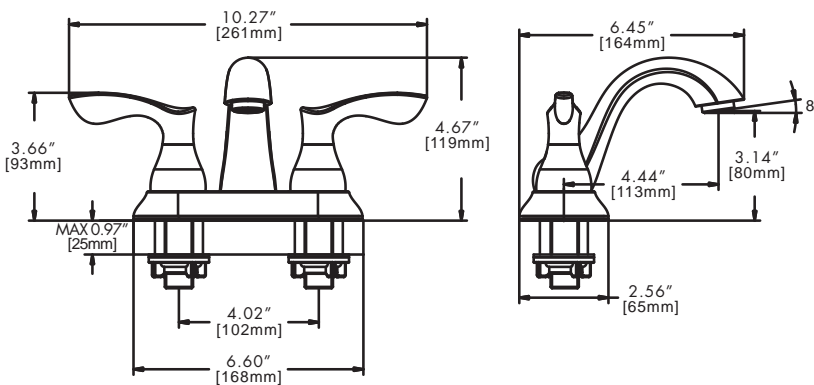

THIS SPACE FOR ARCHITECT/ENGINEER APPROVAL.

SPEAKMAN®

400 ANCHOR MILL ROAD | NEW CASTLE, DE 19720
P: 800-537-2107 | F: 800-977-2747
WWW.SPEAKMANCOMPANY.COM



REVISION DATE: JAN 2013