

SPEAKMAN RAINIER™

Showerhead S-3018

SPECIFICATION

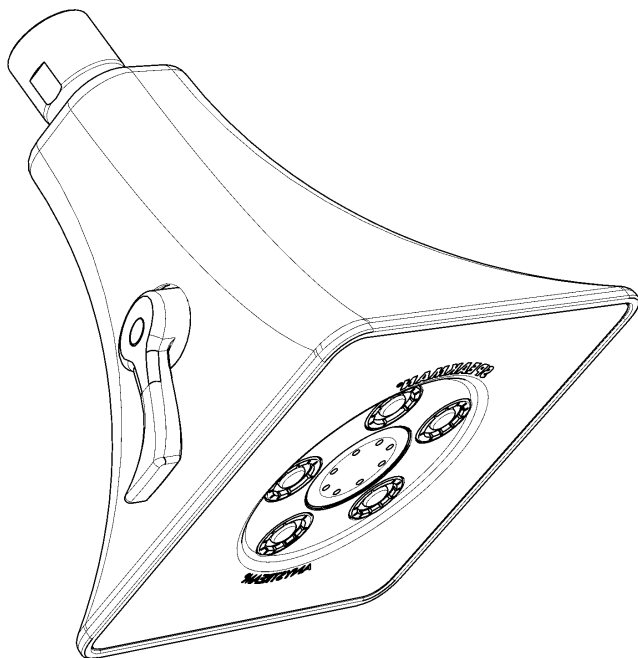

FEATURES:

- 50 adjustable spays
- Massage spray setting
- Square design
- 360° spray adjusting handle

AVAILABLE FINISHES:

ADD SUFFIX TO MODEL #

- Polished Chrome (standard)

COMPLIANCE:

- Certified to ASME A112.18.1/CSA B125.1 standards
- WaterSense certified (E2)



OPTIONS:

- 2.0 gpm (7.6 L/min) flow rate -E2

WARRANTY:

- 1 year limited

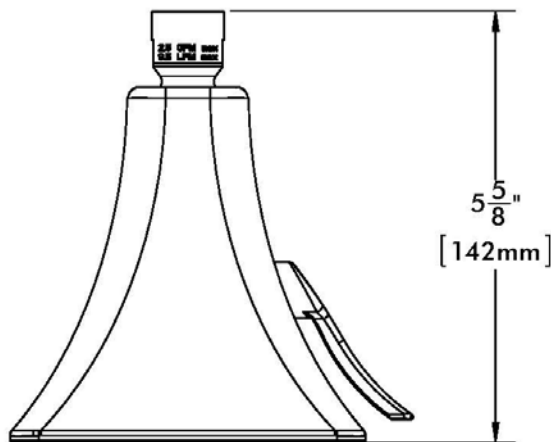
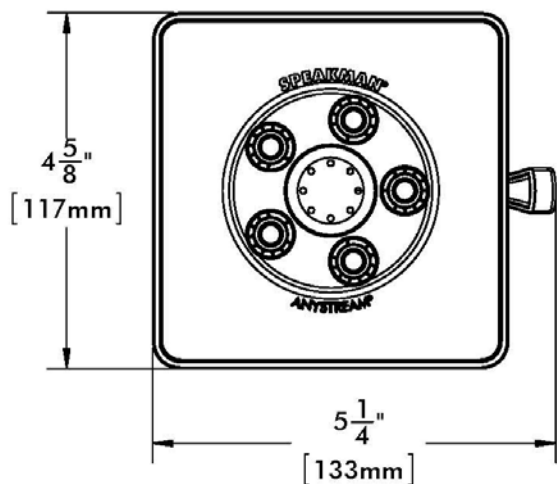

NOTE: 1. All dimensions are in inches (millimeters) unless otherwise specified and are subject to change without notice.

THIS SPACE FOR ARCHITECT/ENGINEER APPROVAL.

SPEAKMAN®

400 ANCHOR MILL ROAD | NEW CASTLE, DE 19720
P: 800-537-2107 | F: 800-977-2747
WWW.SPEAKMANCOMPANY.COM



REVISION DATE: JULY 2012

SPEAKMAN RAINIER™

Accessories

SPECIFICATION

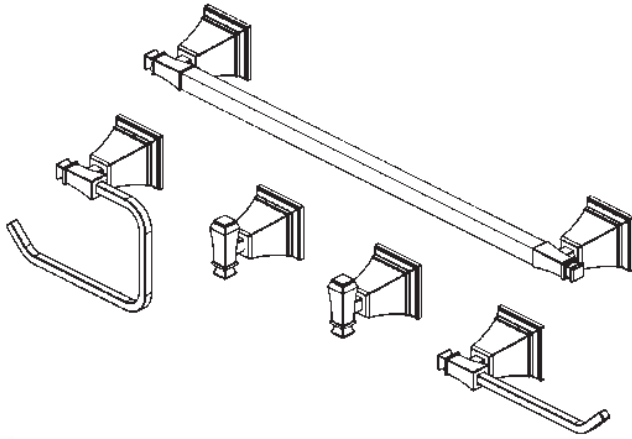

FEATURES:

- SA-1307: 24" towel bar(1)
- SA-1304: Towel ring(1)
- SA-1305: Paper holder(1)
- SA-1306: Robe hook(2)
- Metal construction

AVAILABLE FINISHES:

ADD SUFFIX TO MODEL #

- Polished Chrome (standard)

WARRANTY:

- 1 year limited

Robe Hook
SA-1306

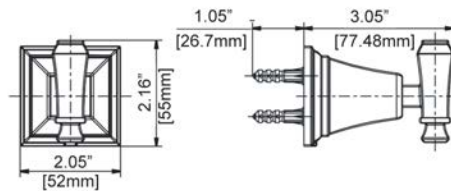

Towel Ring
SA-1304

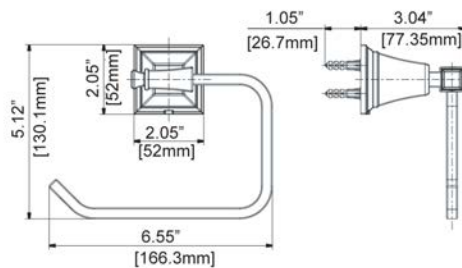

Tissue Holder
SA-1305

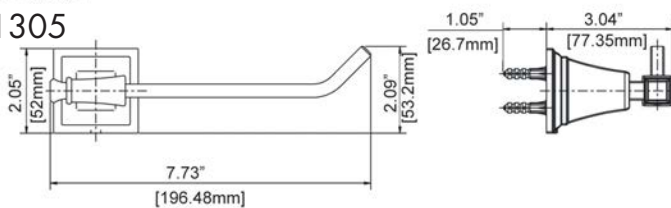

Towel Bar
SA-1307

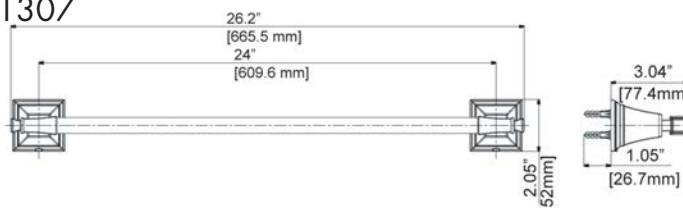

NOTE: 1. All dimensions are in inches (millimeters) unless otherwise specified and are subject to change without notice.

THIS SPACE FOR ARCHITECT/ENGINEER APPROVAL.

SPEAKMAN®

400 ANCHOR MILL ROAD | NEW CASTLE, DE 19720
P: 800-537-2107 | F: 800-977-2747
WWW.SPEAKMANCOMPANY.COM



REVISION DATE: DEC. 2012

SPEAKMAN RAINIER™

4" Centerset Faucet SB-1311

SPECIFICATION

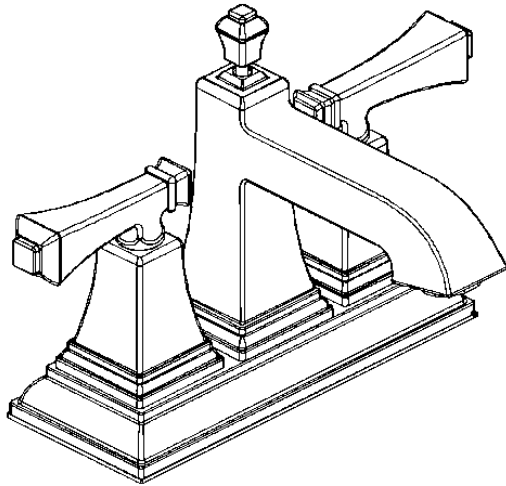

FEATURES:

- Lead-free brass construction
- ¼ turn ceramic cartridge
- 1.5 gpm flow rate
- Square style
- Includes drain assembly

COMPLIANCE:

- Certified to ASME A112.18.1/CSA B125.1, NSF61 WaterSense standards
- CA AB 1953 certified



AVAILABLE FINISHES:

ADD SUFFIX TO MODEL #

- Polished Chrome (standard)

WARRANTY:

- 1 year limited

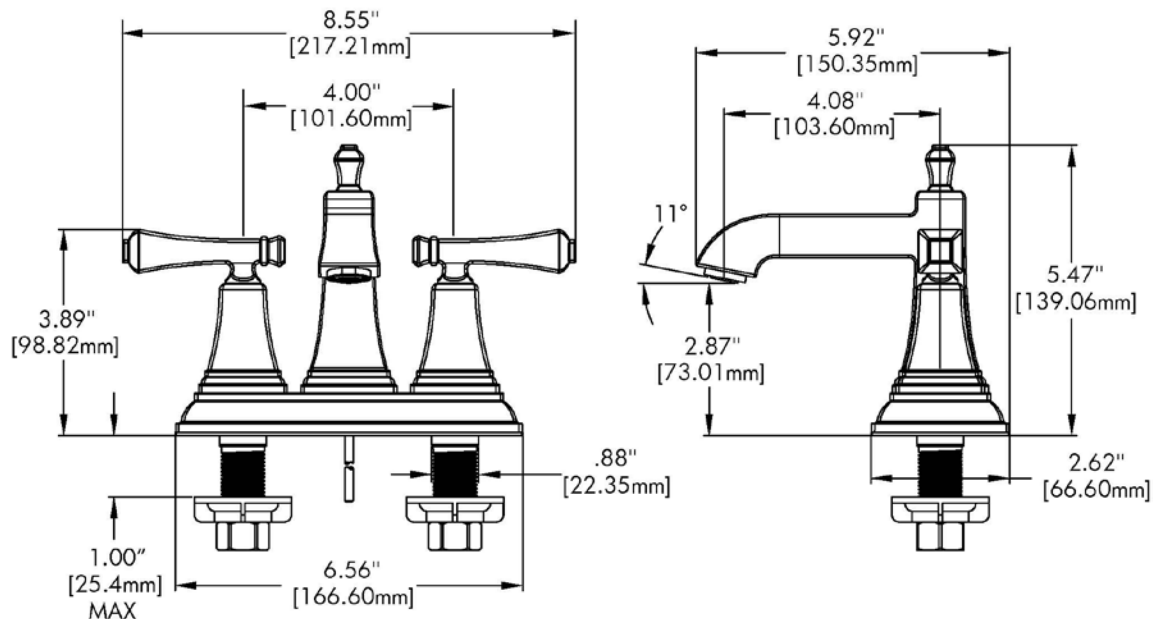

NOTE: 1. All dimensions are in inches (millimeters) unless otherwise specified and are subject to change without notice.

THIS SPACE FOR ARCHITECT/ENGINEER APPROVAL.

SPEAKMAN®

400 ANCHOR MILL ROAD | NEW CASTLE, DE 19720
P: 800-537-2107 | F: 800-977-2747
WWW.SPEAKMANCOMPANY.COM

Management Systems
Registered to ISO 9001

REVISION DATE: FEB. 2013