

Alexandria Shower Combination

FEATURES:

- Alexandria Shower Head S-3011
- Arm and Flange S-2500
- Alexandria Pressure Balance Valve and Trim SM-6000-P
- Alexandria Diverter Tub Spout S-1560
- 2.5 gpm (9.5 L/min) flow rate

FINISH:



PC BN

COMPLIANCE:

- ASME A112.18.1/CSA B125.1 compliant

MODELS:

- SM-6030-P: with S-1560 diverter tub spout
- SM-6010-P: without S-1560 diverter tub spout

WARRANTY:

- Consumer Shower Head: Limited Lifetime Warranty
- Commercial Shower head: 1 Year Limited
- Valve: 5 Year Limited
- Accessories: 1 Year Limited



DIMENSIONS: NOTE: 1. All dimensions are in inches (millimeters) unless otherwise specified and are subject to change without notice. 2. Unless otherwise specified, all inlets and outlets are 1/2" female copper sweat. 3. For ADA mounting locations, consult ADAAG, ANSI A117.1, or static regulations.
Contractor pack valves & trim kits available.

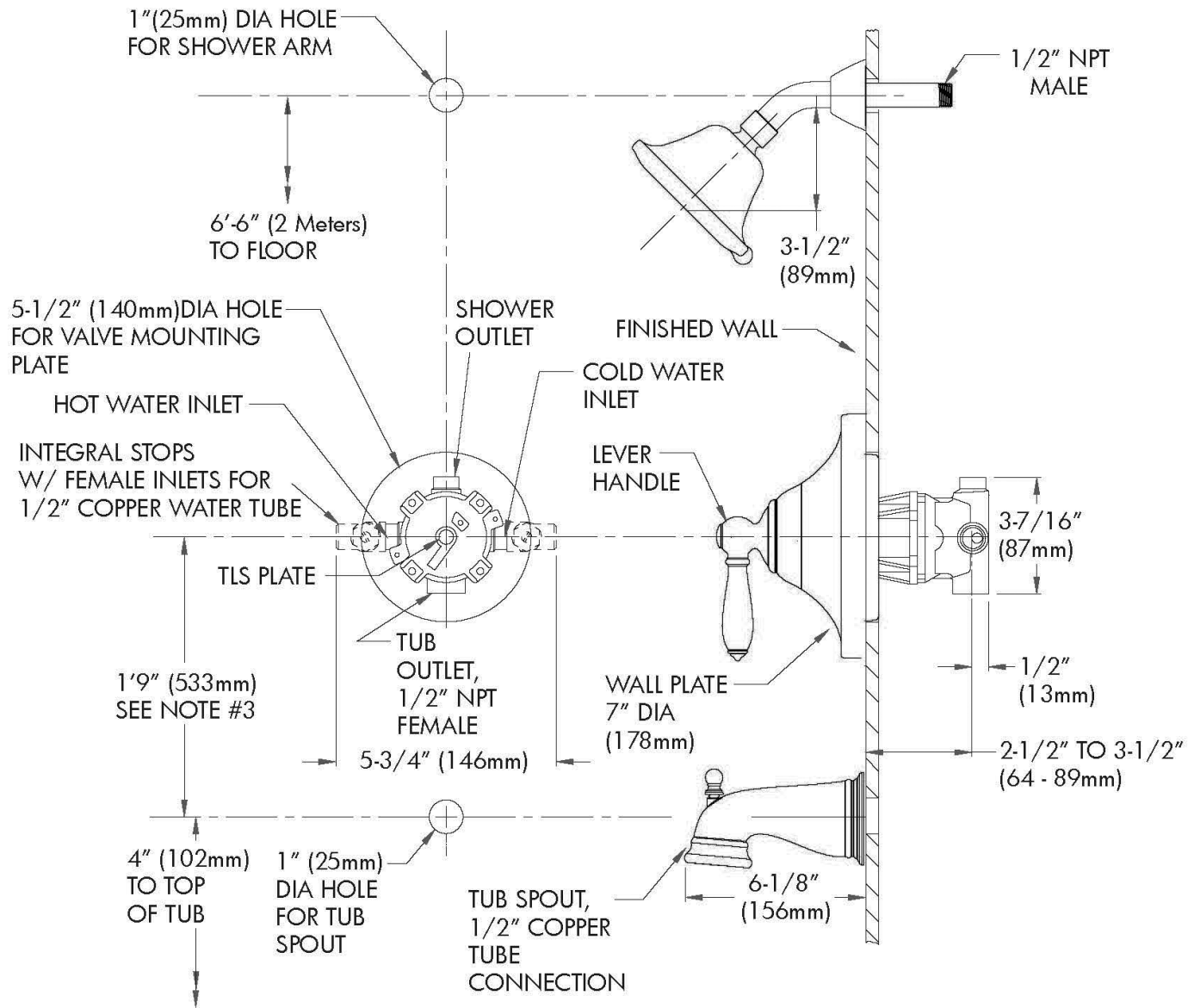

Architect/Engineer Approval Space:

SPEAKMAN
400 ANCHOR MILL ROAD
NEW CASTLE, DE 19720

P: 800-537-2107
F: 800-977-2747
W: WWW.SPEAKMAN.COM
R: JANUARY 2017