

# SPEAKMAN® SE-572

## Laboratory Countertop Mounted Eyewash

### FEATURES:

- Countertop mounted
- (2) yellow, plastic, aerated with flip-top dust caps
- ½ in. NPT female brass, chrome-plated valve
- Stainless steel push handle activation
- ½ in. NPT male inlet
- 3.2 GPM (12.1 L/min) @ 30 psi
- Universal emergency sign included

### FINISHES:



Chrome

### COMPLIANCE:

- ANSI/ISEA Z358.1 certified

### OPTIONS:

Add suffix to model #

- Left hand operation  LH
- In-line strainer for ½ in. IPS piping  ILS

### WARRANTY:

- 3 year limited

### DIMENSIONS:

NOTE: 1. All dimensions are in inches (millimeters) unless otherwise specified and are subject to change without notice.

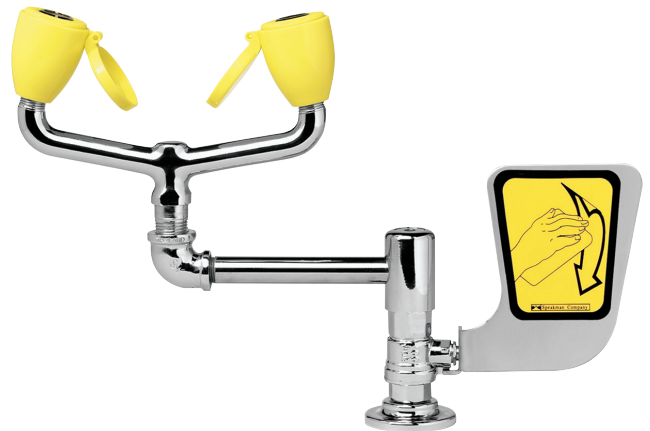
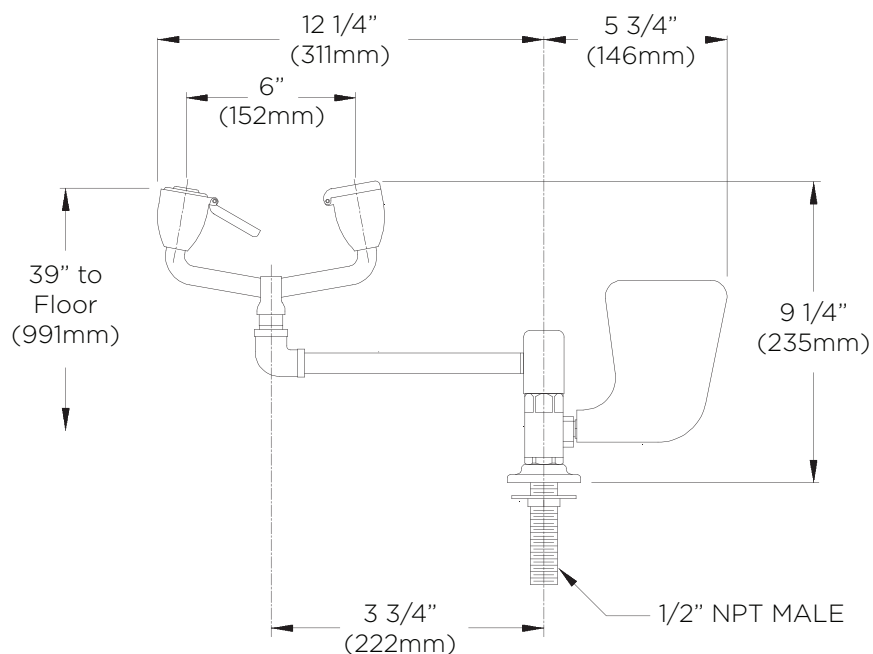

Architect/Engineer Approval Space:

SPEAKMAN  
400 ANCHOR MILL ROAD  
NEW CASTLE, DE 19720

P: 800-537-2107  
F: 800-977-2747  
W: WWW.SPEAKMAN.COM  
R: FEBRUARY 2018