

► **Code Number**

3250325

► **Flush Cycle**

☐ 0.125 gpf/0.5 lpf

► **Specifications**

Quiet, Exposed, Chrome Plated Urinal flushometer for either left or right hand supply with the following features:

- Flex Tube Diaphragm designed for improved life and reduced maintenance
- Synthetic rubber seals for chloramine resistance
- Initial Set-up Range Indicator Light (first 10 minutes)
- "Low Battery" Flashing LED
- Sweat solder adapter with cover tube and cast wall flange with set screw
- Spud coupling and flange for 3/4" top spud
- Stop Seat and Vacuum Breaker Molded from PERMEX® Rubber Compound for Chloramine resistance
- 3/4" I.P.S. Screwdriver Bak-Chek® Angle Stop with free spinning, vandal resistant Stop Cap
- Infrared Sensor with Multiple-focused, Lobular Sensing Fields for high and low target detection
- Latching Solenoid Operator
- Fixed Metering Bypass and No External Volume Adjustment to Ensure Water Conservation
- Engineered Metal Cover with replaceable Lens Window
- Four (4) Size AA alkaline Batteries included: Duracell® with DURALOCK Power Preserve Technology™-guaranteed for up to 10 years in storage
- Courtesy Flush® Override Button (optional)
- Reduces water usage up to 80% over standard sensor urinal
- ADA Compliant Sloan ECOS® Battery powered Infrared Sensor for automatic "No Hands" operation

Valve Body, Tailpiece and Control Stop shall be in conformance with ASTM Alloy Classification for Semi-Red Brass. Valve in compliance with the applicable sections of ASSE 1037. Installation conforms to ADA requirements.



► **Automatic Operation**

Sloan ECOS® electronic flushometers are activated via multi-lobular infrared sensor. By detecting user presence and duration, the Sloan ECOS® Smart Sense Technology™.

► **Smart Sense Technology™**

The Sloan ECOS® flushometer is equipped with Smart Sense Technology™ which applies extended range and logic techniques to significantly reduce water usage in high use urinal applications

► **Functional & Hygienic**

Touchless, sensor operation eliminates the need for user contact to help control the spread of infectious diseases.

► **Compliance & Certifications**



Made In The USA

This space for Architect/Engineer Approval

► **ROUGH-IN**

► Control Circuit

- Solid State
- 6 VDC Input
- 8 Second Arming Delay
- 3 Second Flush Delay

► Sensor Type

Active Infrared

► Indicator Lights

Range Adjustment

► Operating Pressure

15 - 100 psi (104 - 689 kPa)

► Sentinel Flush

Automatic flush once every 72 hours after the last flush. Product shipped from factory with feature turned off. Consult factory to activate.

► Battery Life

6 Years @ 4,000 flushes/month

► Battery Type

(4) Size AA Alkaline: Duracell® with DURALOCK Power Preserve Technology™

► Description

Exposed, battery-powered, sensor-activated Sloan ECOS® electronic urinal flushometer with Smart Sense Technology™.

► Sensor Range

Nominal 15" - 30" (381 mm - 762 mm), Adjustable ± 8" (203 mm)

► OPERATION

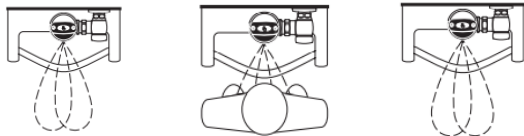

1. A continuous, invisible light beam is emitted from the Sloan ECOS® Sensor.
2. As the user enters the beam's effective range, 15" - 30" (381 mm to 762 mm), the beam is reflected into the scanner window to activate the output circuit. Once activated, the Output Circuit continues in a "hold" mode for as long as the user remains within the effective range of the sensor.
3. When the user steps away from the Sloan ECOS® sensor the sensor initiates an electrical signal that operates the solenoid. This initiates the flushing cycle to flush the fixture. The circuit then automatically resets and is ready for the next user.

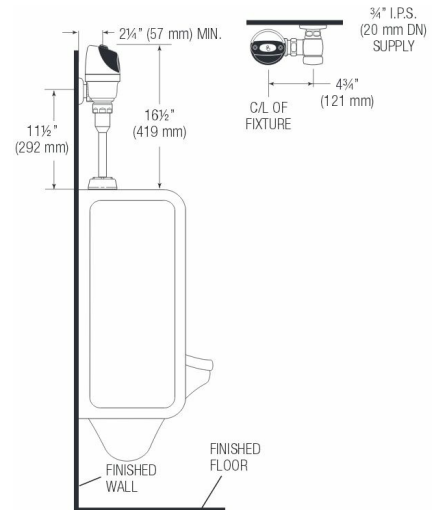

Model 8186

