

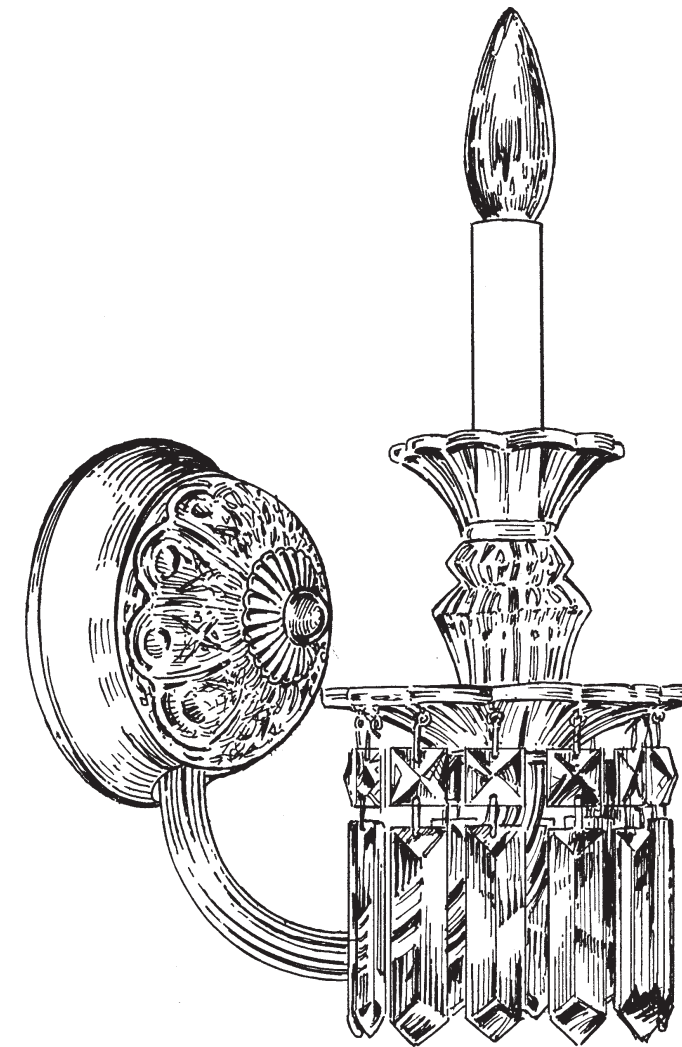

**SCHONBEK®**

# FAIRFAX 5035



**T**HIS DESIGN IS THE PROPRIETARY TRADE DRESS/TRADemark OF SWAROVSKI LIGHTING, LTD.

1 Light  
Diameter: 5"  
Body Length: 12-1/2"  
Extension: 8"  
Hanging Weight: 2-1/2 lbs.



**SCHONBEK®**

MAX 60 W		110-120 V						

SCHONBEK® is a member of the Swarovski group.

All electrical components must be installed by a licensed electrician in accordance with the National Electric Code and the appropriate local electrical codes.

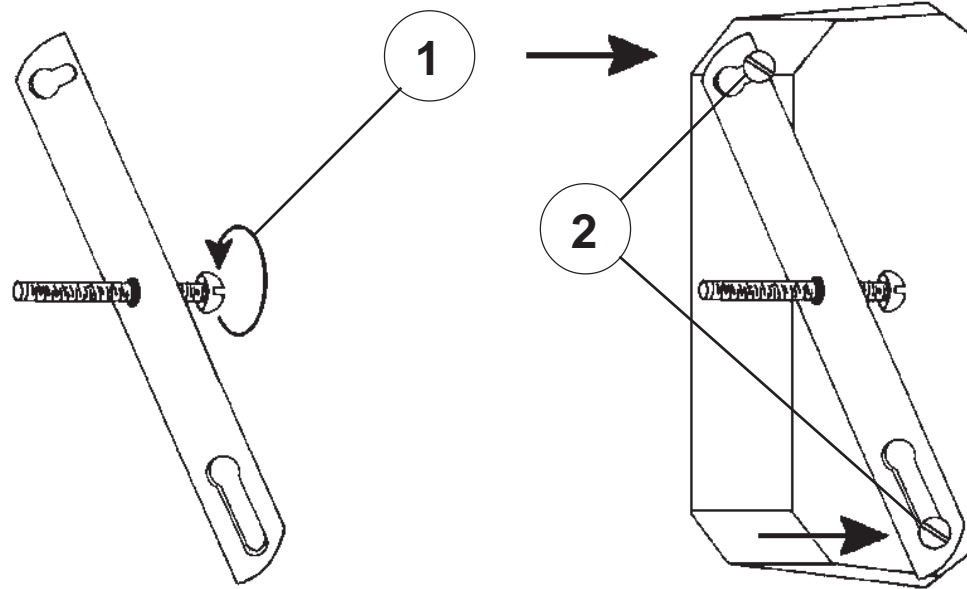

3  
Turn arms to line up holes in arms with dimple in plate. Tighten lock washer and nut to secure arms in place.

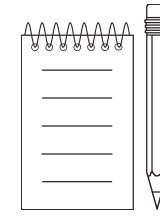
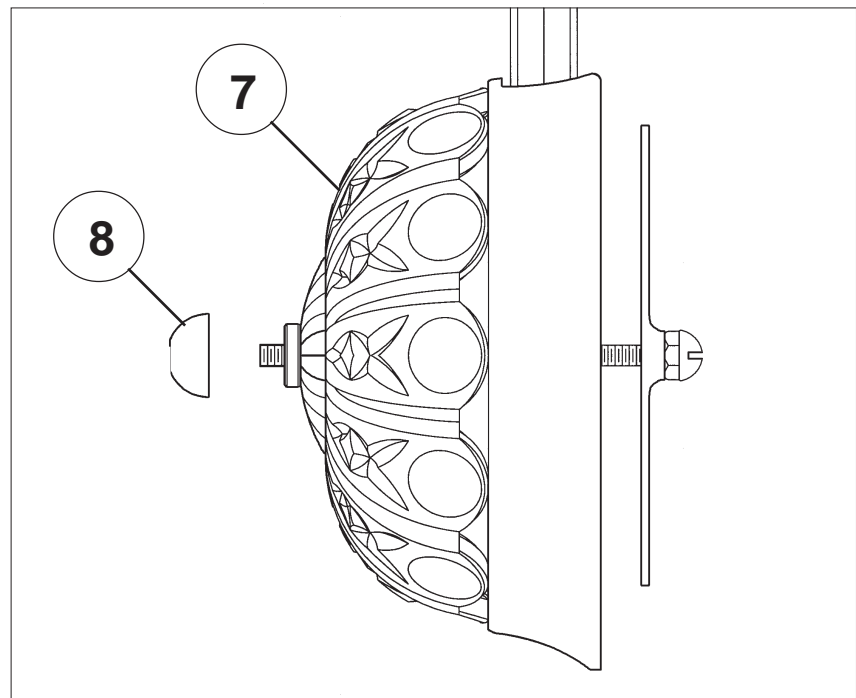
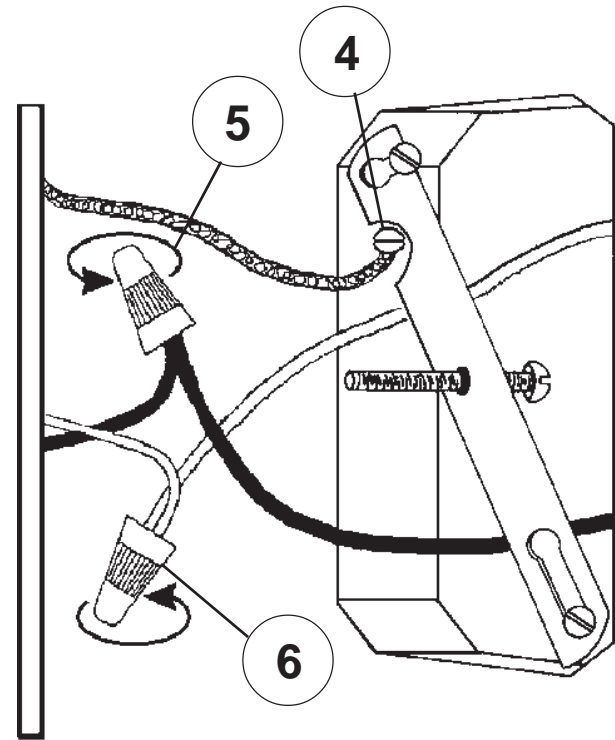
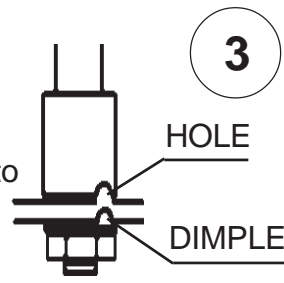





9

You will need 1 - B10  
25 Watts Recommended  
60 Watts Max

Install bulbs and be sure  
to test fixture **BEFORE**  
trimming.

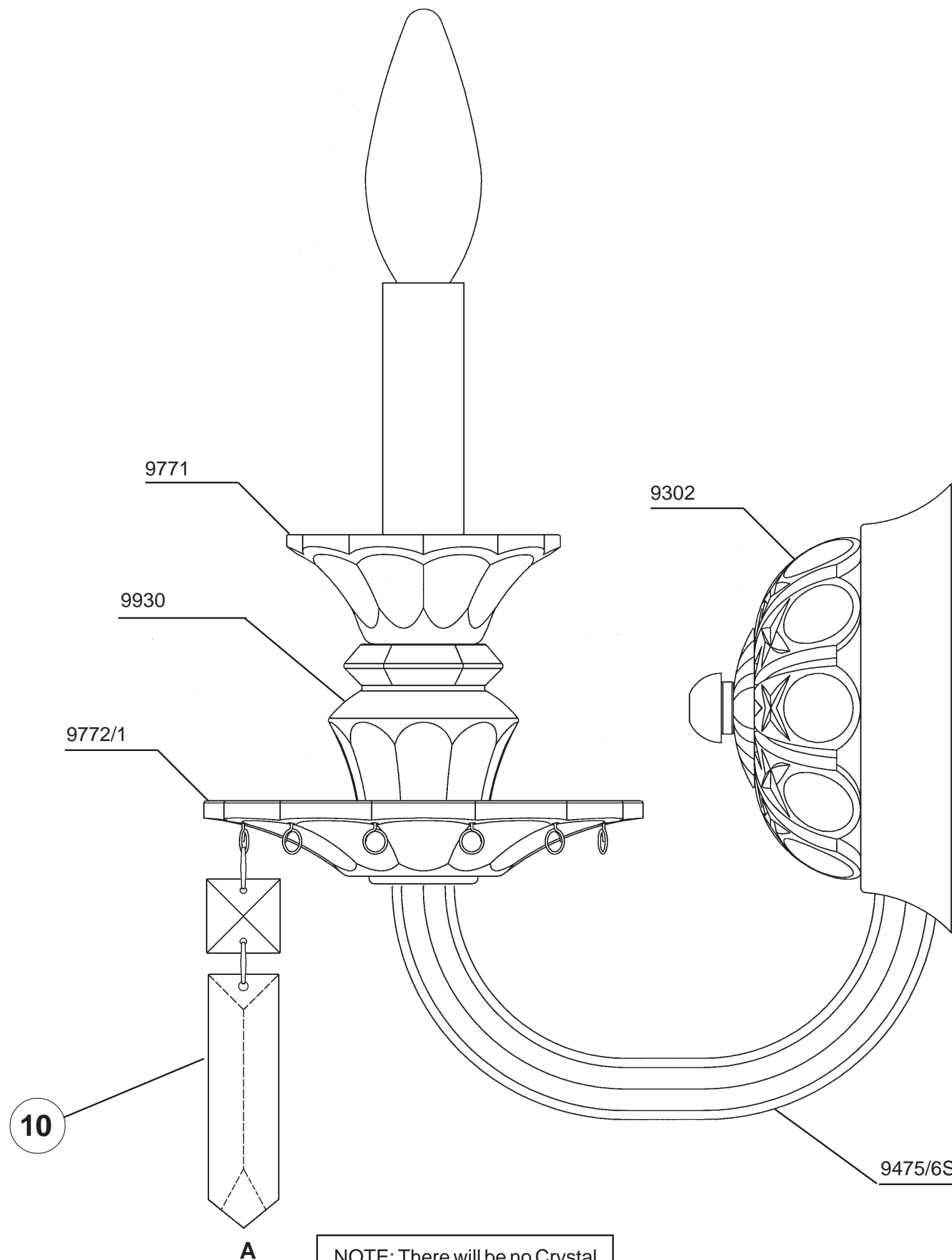

NOTE: There will be no Crystal  
"A" hung where the arm is  
because it will hit the arm.

**CAUTION:**  
Glass parts are fragile. To Avoid  
breakage use care when  
assembling or cleaning.

