

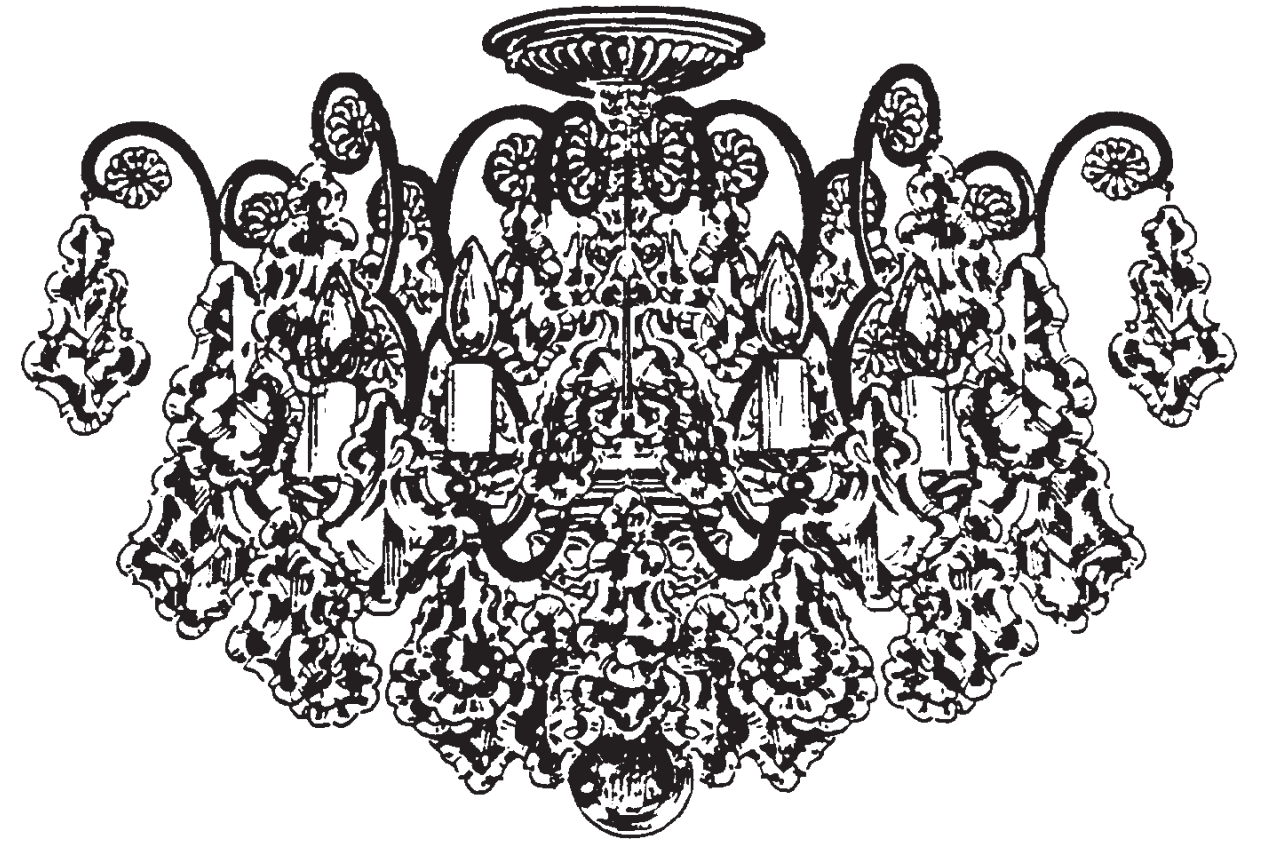

SCHONBEK®

VERSAILLES 2784- _ _ _



THIS DESIGN IS THE PROPRIETARY TRADE DRESS/TRADemark OF SWAROVSKI LIGHTING, LTD.

6 Lights
Diameter: 20"
Body Length: 15-1/2"
Hanging Weight: 13-1/2 lbs.



SCHONBEK®

MAX 40 W		110-120 V					

SCHONBEK® is a member of the Swarovski group.

All electrical components must be installed by a licensed electrician in accordance with the National Electric Code and the appropriate local electrical codes.

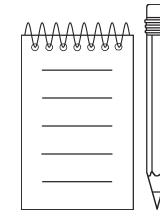
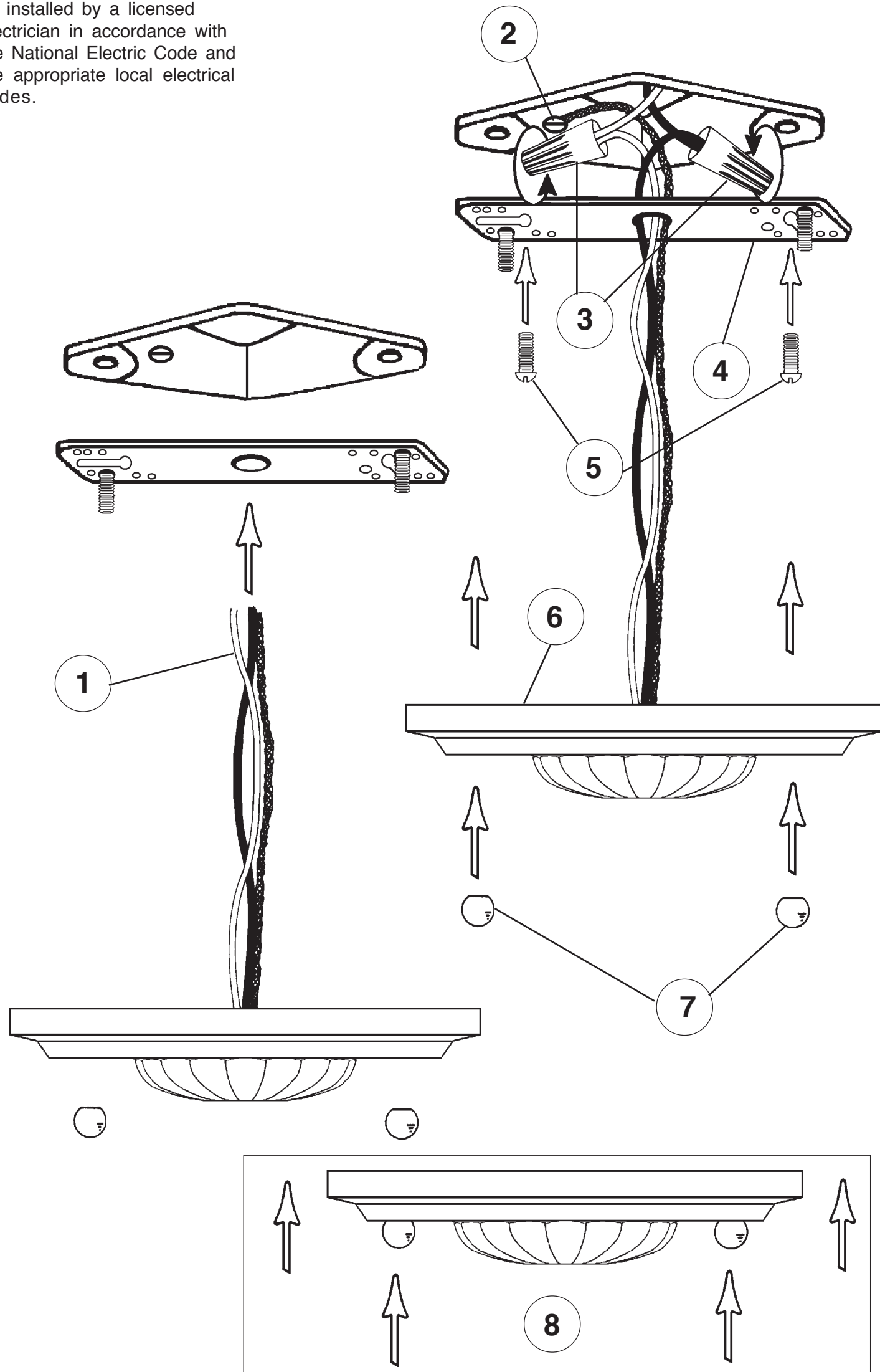

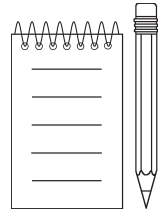

SET #1

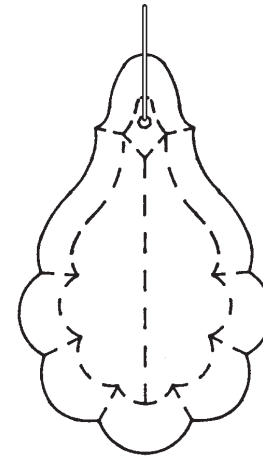

N5031
2-1/2"
63mm

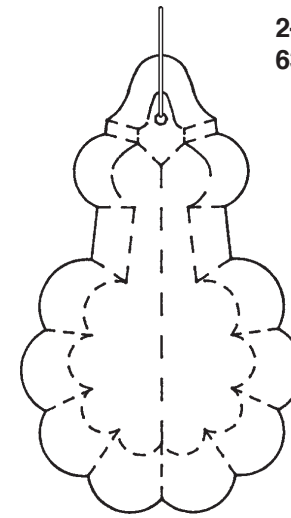

N5020
3"
76mm

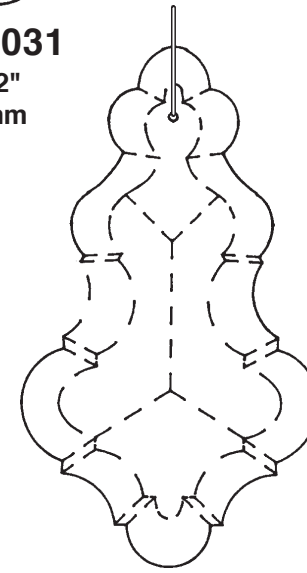

N5000
3-1/2"
89mm

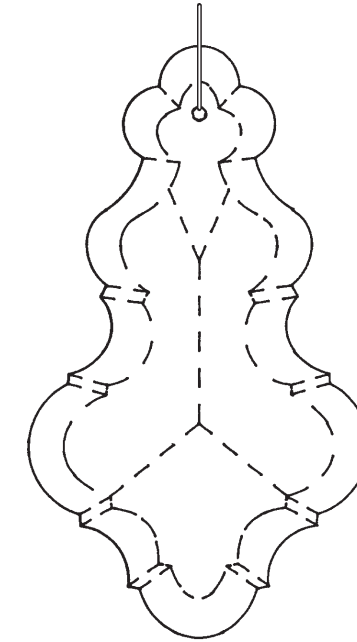

N5003
4"
102mm

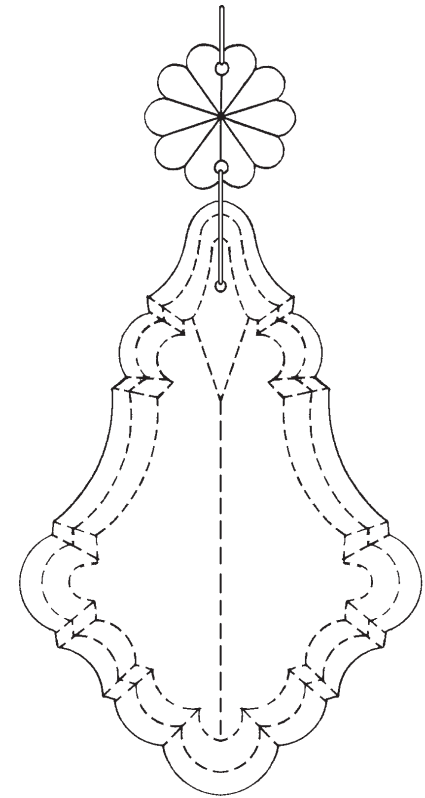

N5029
4"
102mm

SET #2

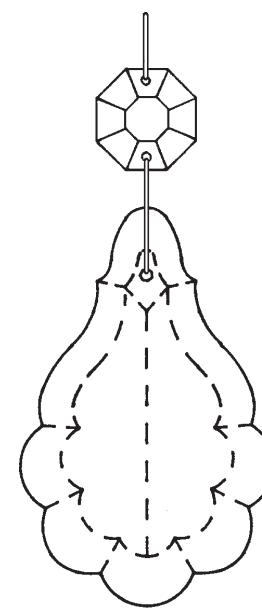

N5032
2-1/2"
63mm

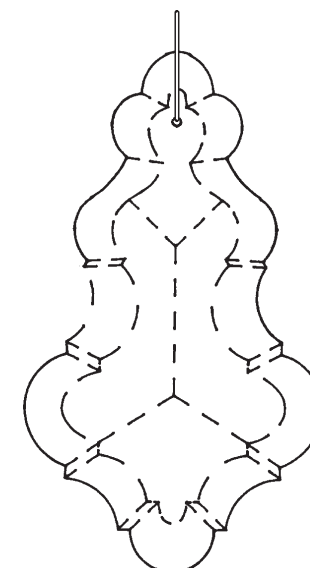

N5000
3-1/2"
89mm

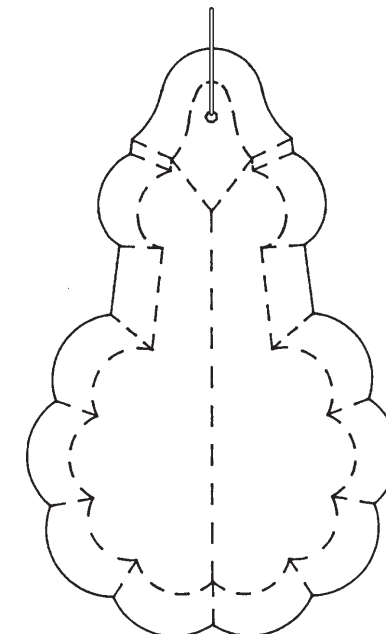

N5013
4"
102mm

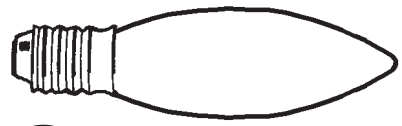

9 6 - B10
40 Watts Max
25 Watts Recommend

Crystal Set #1 in Black

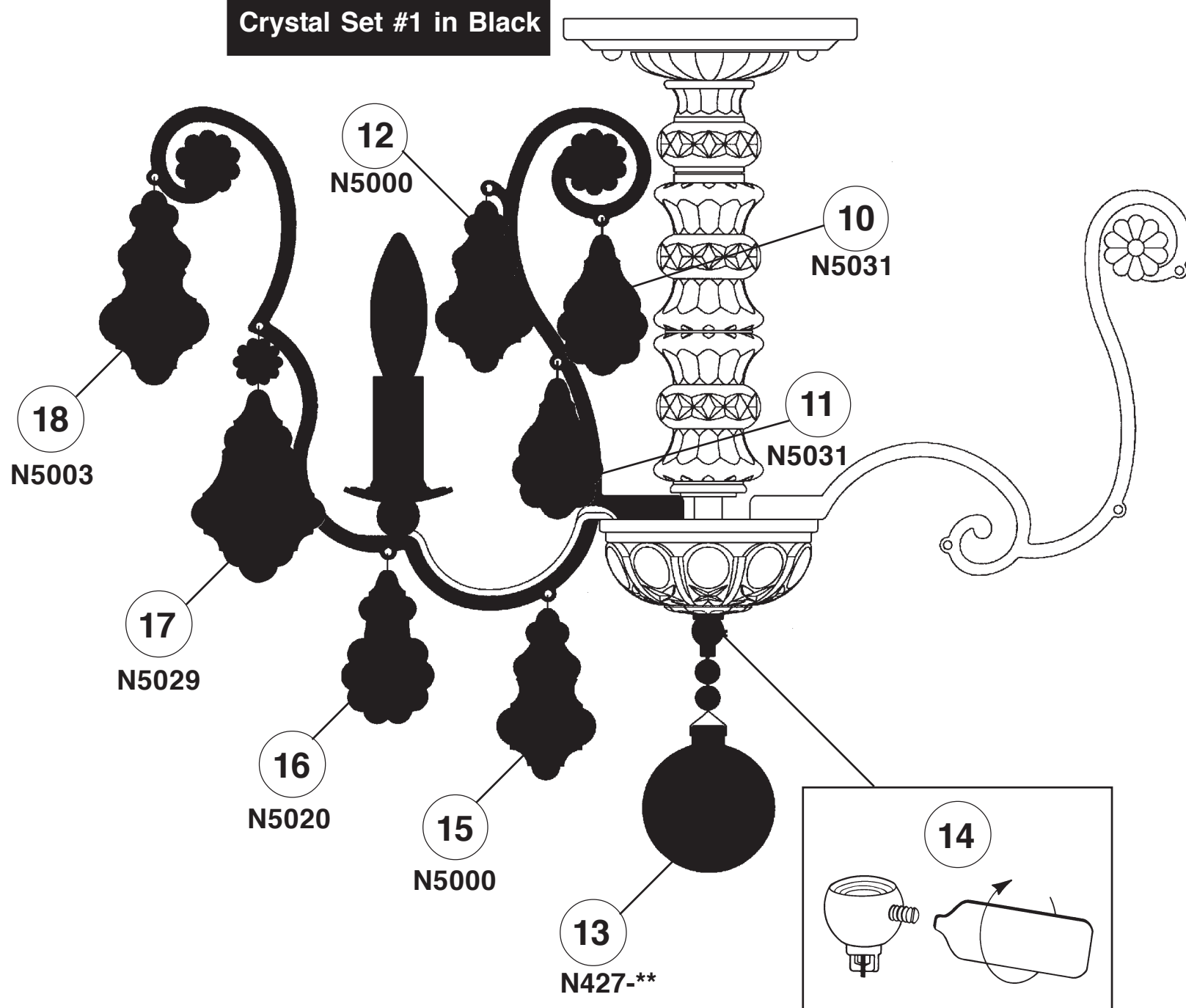

Crystal Set #2 in Black

