

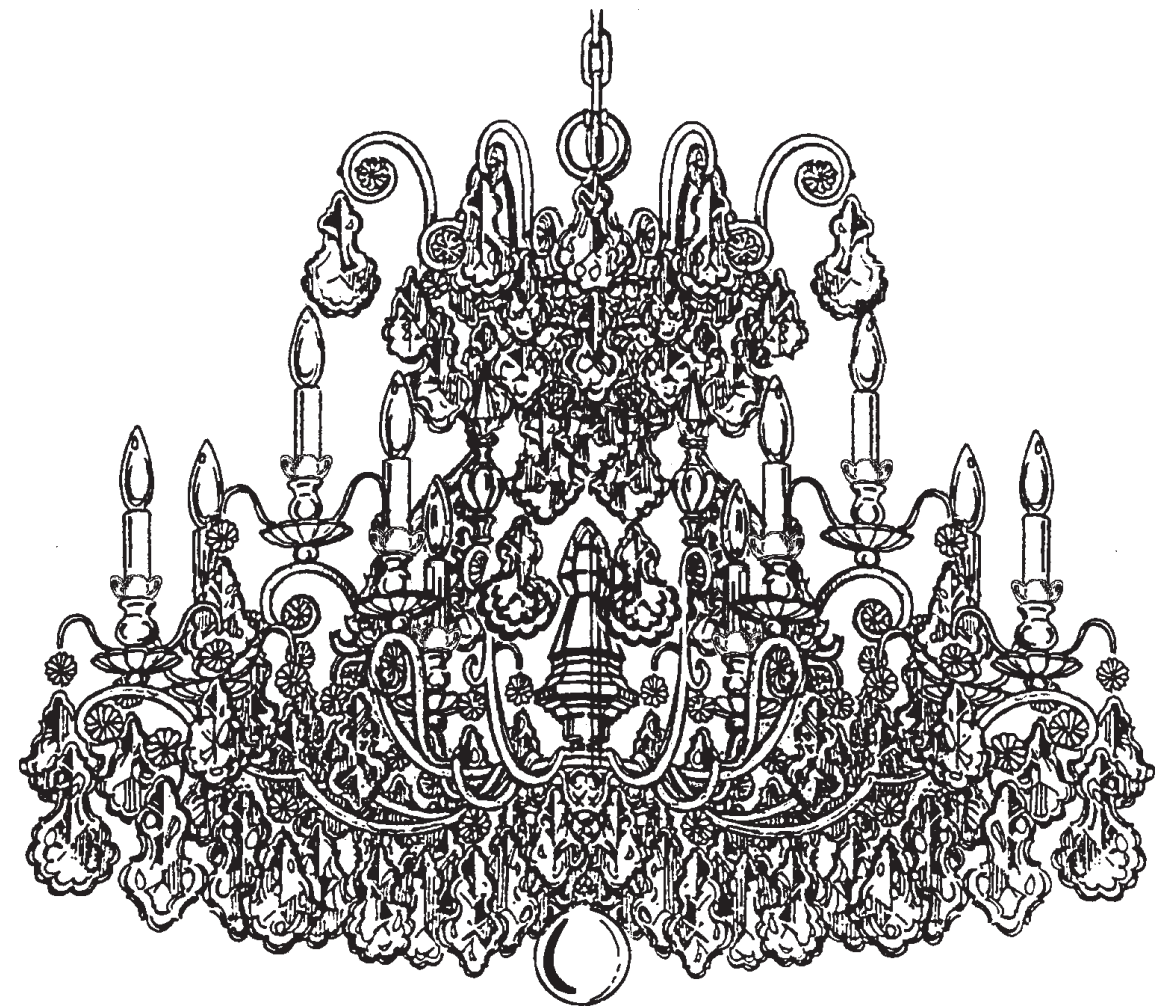

SCHONBEK®

VERSAILLES 2792- _ _ _



THIS DESIGN IS THE PROPRIETARY TRADE DRESS/TRADemark OF SWAROVSKI LIGHTING, LTD.

18 + 1 Lights
Diameter: 40"
Body Length: 28"
Hanging Weight: 54 lbs.



SCHONBEK®

MAX <u>60</u> W	MAX <u>15</u> W	110-120 V					

SCHONBEK® is a member of the Swarovski group.

All electrical components must be installed by a licensed electrician in accordance with the National Electric Code and the appropriate local electrical codes.

WARNING: THIS LUMINAIRE MUST BE MOUNTED OR SUPPORTED INDEPENDENTLY OF AN OUTLET BOX.

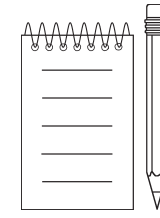
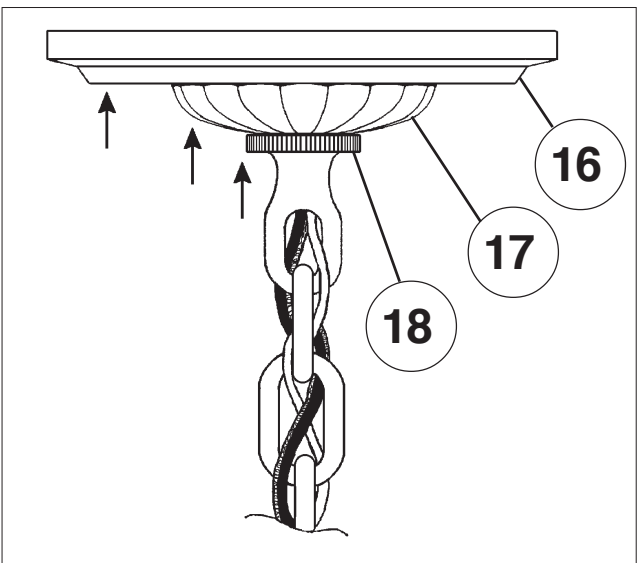
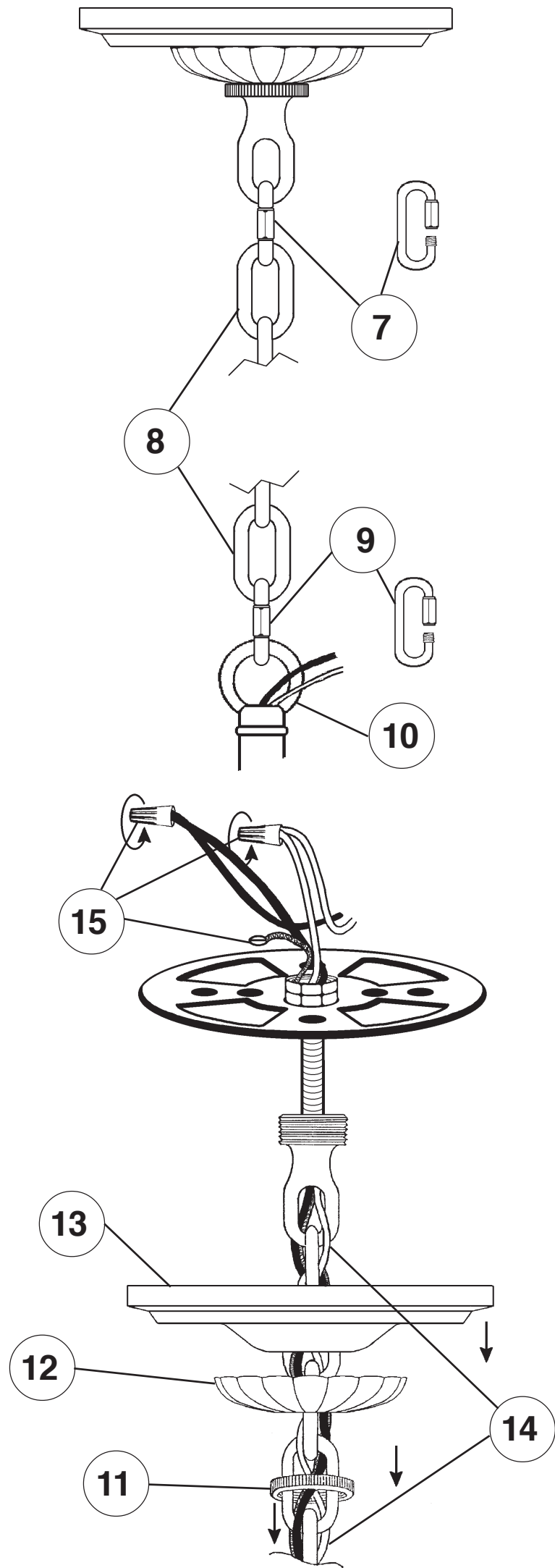
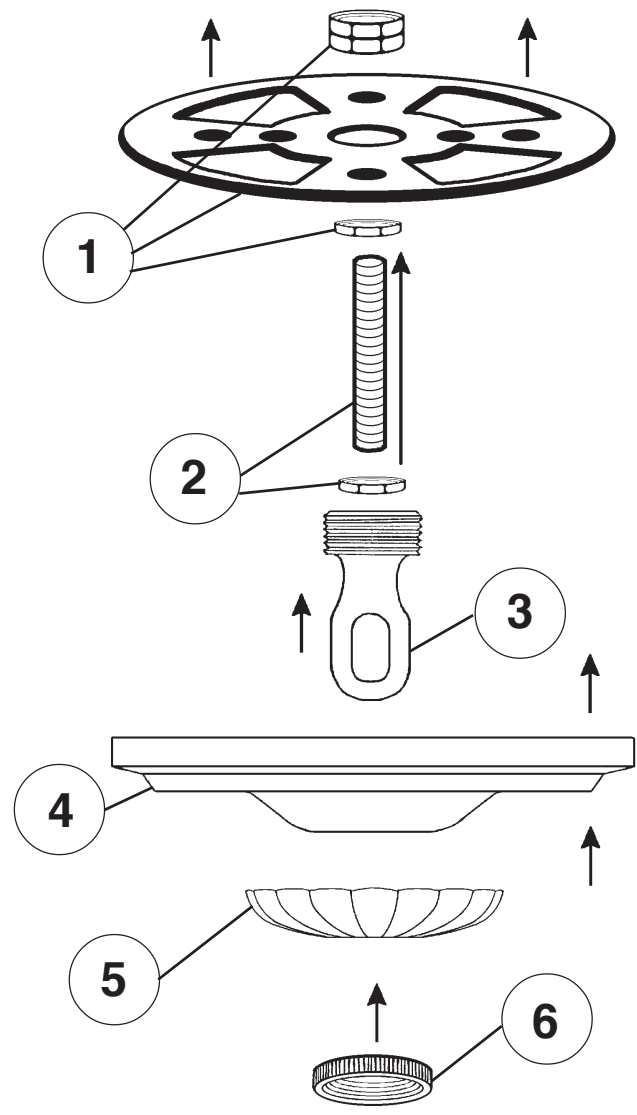

Crystal Set #3 in Black

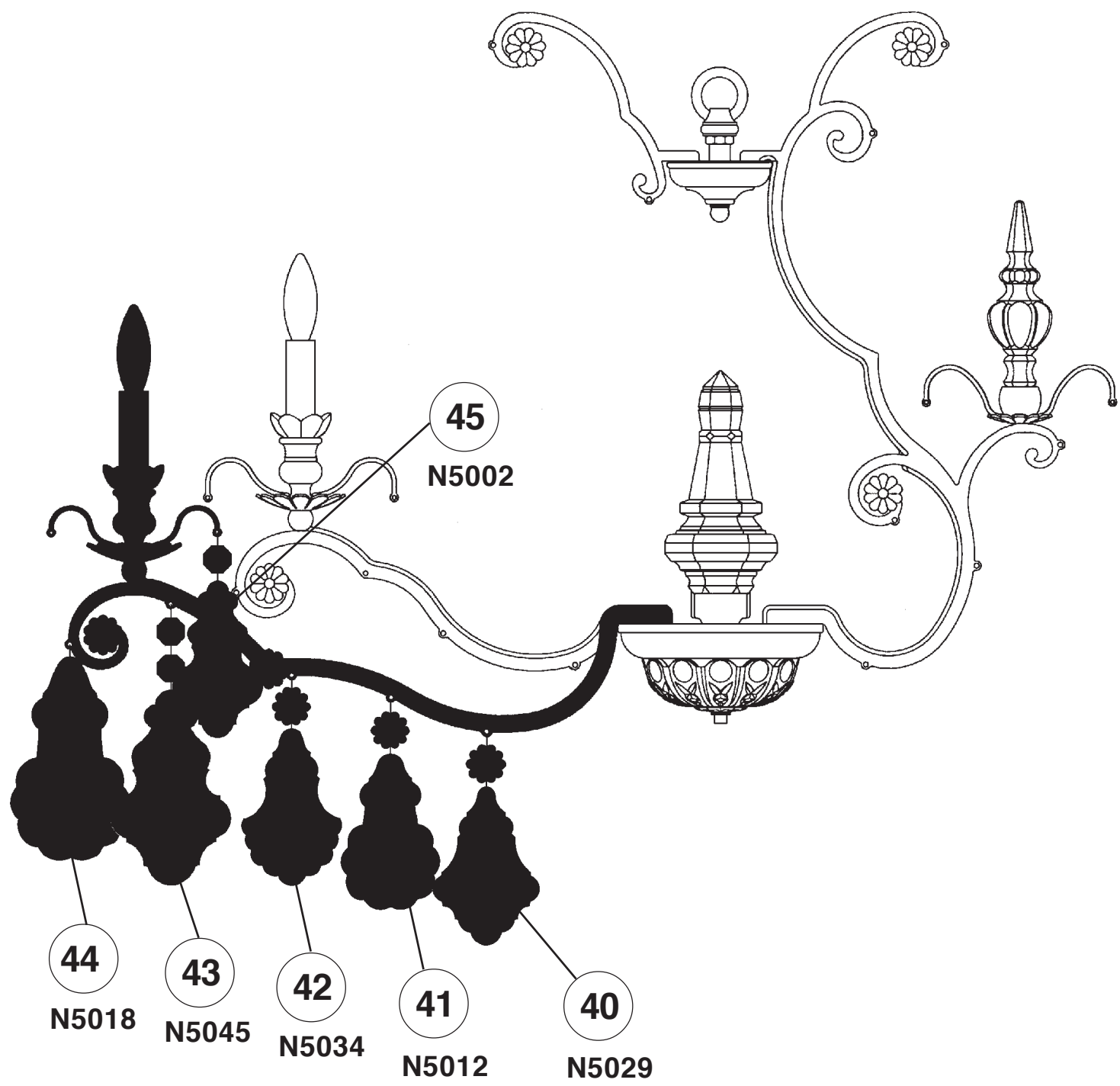

SET #1

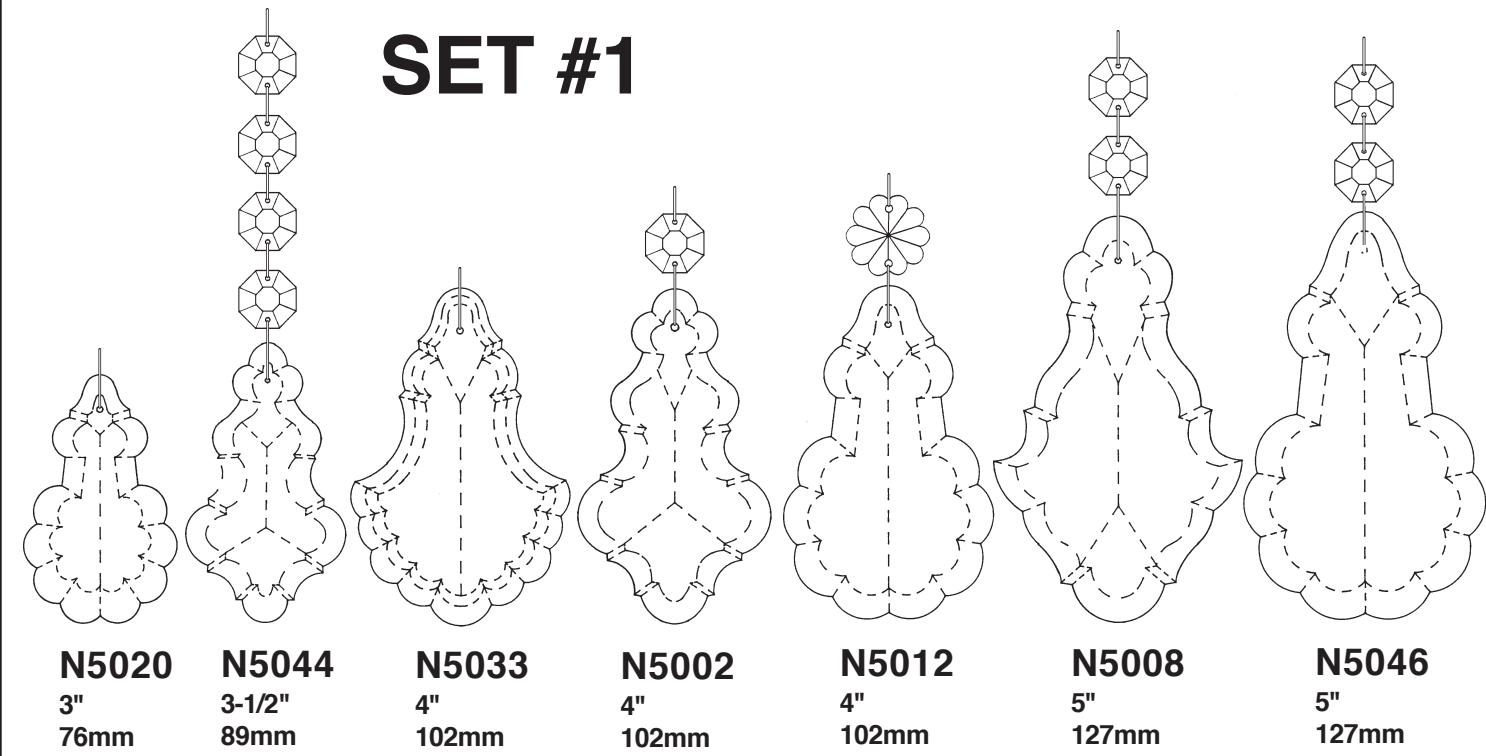

SET #2

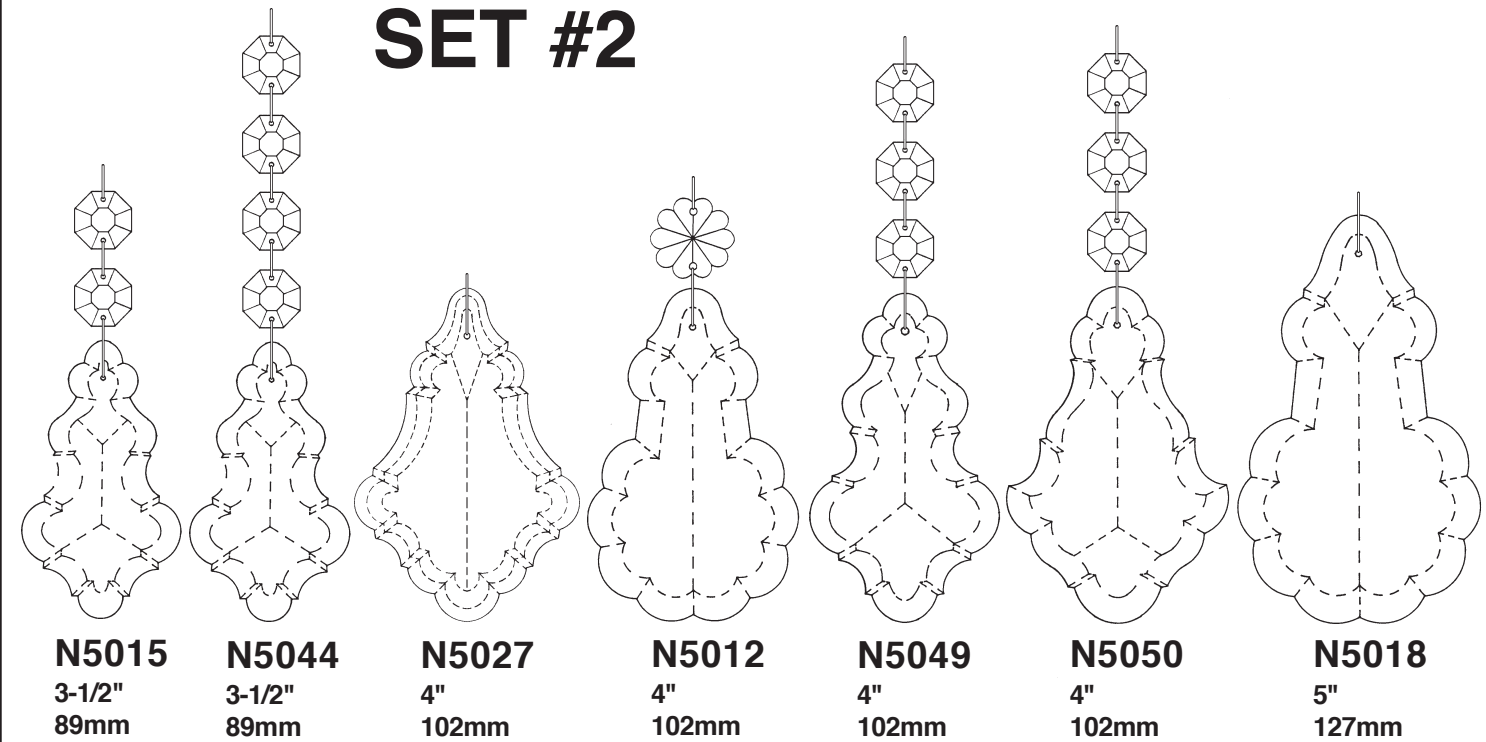

SET #3

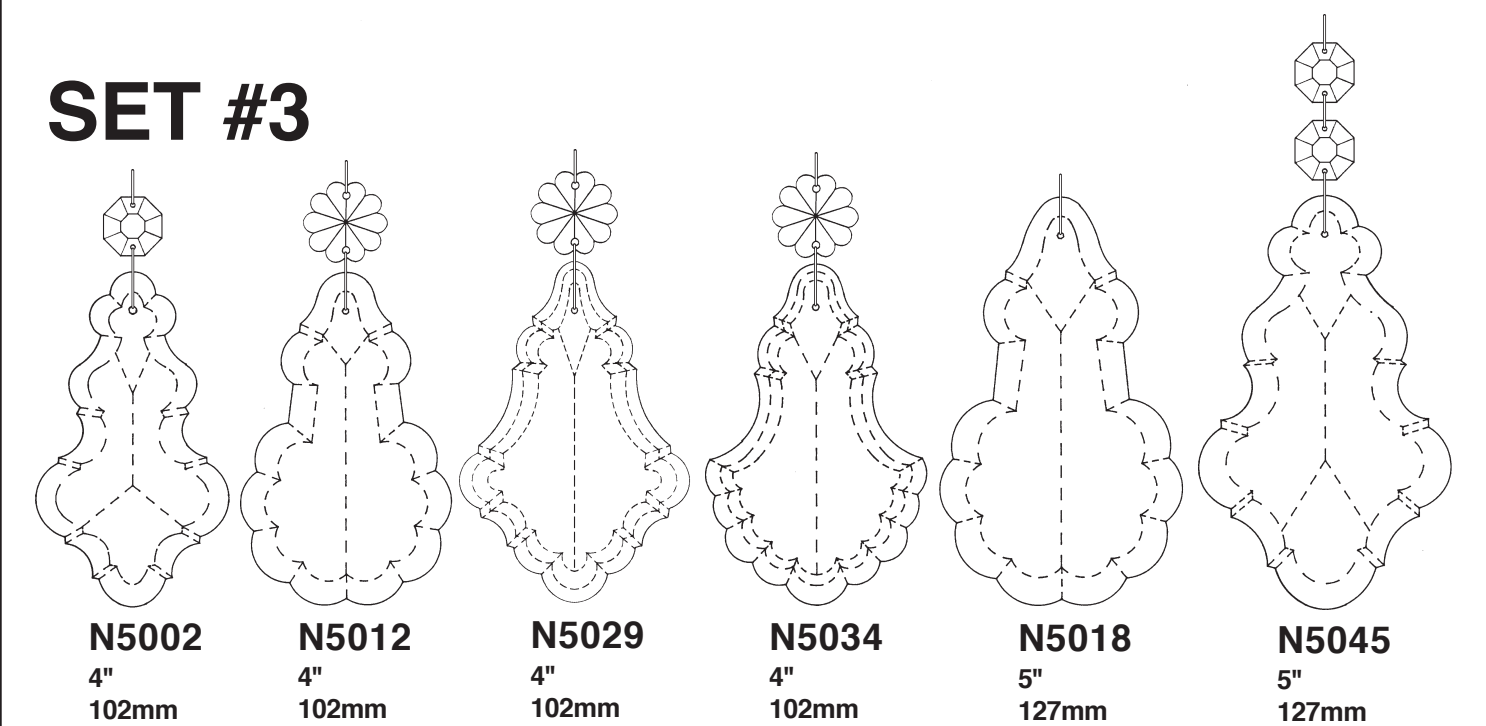

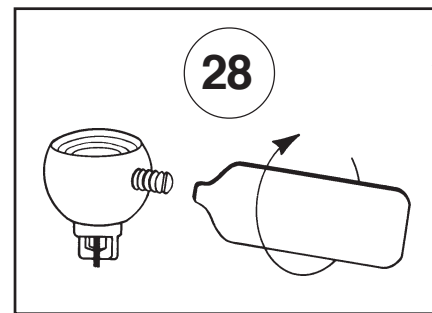
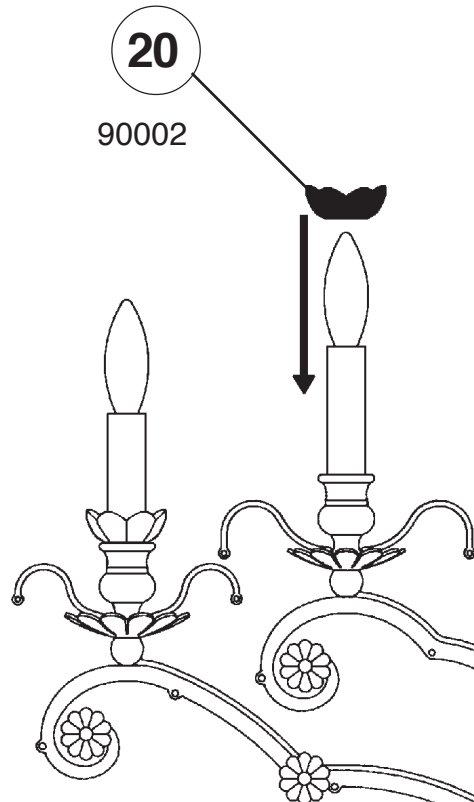
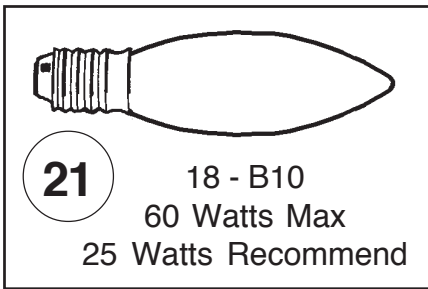
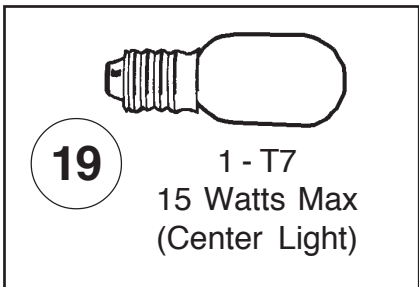

Crystal Set #1 in Black

Crystal Set #2 in Black

