



SMH1622

1.6 cu. ft. Over-the-Range Microwave

Features

- 1.6 cu. ft. Oven Capacity
- 1000 Watts Cooking Power
- 300 CFM Ventilation System
- Charcoal / Grease Vent Filter
- 10 Power Levels
- Four Instant Cook Pads
- Two-Stage Programmable Cooking
- Auto Defrost / Auto Reheat
- Auto Cook: Popcorn, Potato, Veggies, Pizza, Cook (4), Soften / Melt (3)
- MW Distribution Mechanism: Turntable + Stirrer

Convenience

- Kitchen Timer
- Cooktop Lighting: High / Low / Off
- Interior Light: Incandescent
- Vent Fan Control: High / Low / Off
- Child Safety Lock
- Eco Mode (reduces standby power)



Stylish design compliments any kitchen decor and provides the high performance you expect only from Samsung.



Features a blue digital LED Display – compliments any kitchen decor.



Digital touch control lets you easily program the desired cooking time and power.

Signature Features

Available Colors



Auto Defrost Quick and efficient

Defrost items by selecting the weight of the food being cooked, and the microwave does the rest.

Two-Stage Cooking Easy time-savor

This function allows you to easily program initial defrost plus a corresponding two-step recipe for that food simultaneously.

Electronic Touch Control Style and function

Lets you easily program the desired cooking time and power level, at the gentle press of a button, for error-free results every time.

SMH1622

1.6 cu. ft. Over-the-Range Microwave

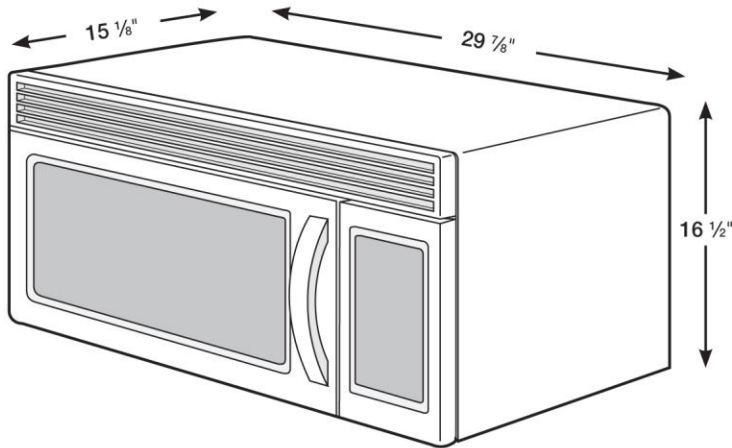

Installing your Microwave

· This microwave oven is designed for adaptation to the following three types of ventilation:

- A. Outside Top Exhaust (Vertical Duct)
- B. Recirculating (Non-Vented Ductless)
- C. Outside Back Exhaust (Horizontal Duct)

- The space between the cabinets must be 30" wide and free of obstructions.
- This microwave oven is for installation over ranges up to 36" wide.
- The Microwave must be level. Use a level to make sure the cabinet bottom is level. If the cabinets have a front overhang only, with no back or side frame, install the mounting plate down the same distance as the front overhang depth. This will keep the microwave level. depth of the front overhang.

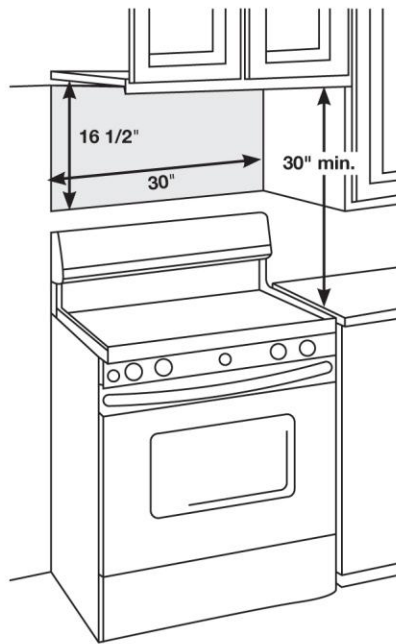

FOR EASIER INSTALLATION AND PERSONAL SAFETY, WE RECOMMEND THAT TWO PEOPLE INSTALL THIS MICROWAVE OVEN. IMPORTANT: Do not grip or use handle during installation.

NOTE: If your cabinet is metal, use the nylon grommet around the power cord hole to prevent cutting of the cord.

NOTE: We recommend using filler blocks if the cabinet front hangs below the cabinet bottom shelf.

IMPORTANT: If filler blocks are not used, case damage may occur from over tightening screws.

NOTE: When mounting the microwave oven, thread power cord through hole in bottom of top cabinet. Do not pinch cord or lift oven by pulling cord.

Specifications

- Oven Cavity: 1.6 cu. ft.
- Power Output: 1000 W
- Power Consumption: 1580 W / 13.5 A
- Power Source: 120 V / 60 Hz
- Control Method: Digital (Membrane Touch)
- Display: LED Bar
- Cooking Control: 10 Power Levels including Defrost
- Cooking Timer: Digital, up to 99 Minutes, 99 Seconds
- Microwave Distribution System: Rotating Turntable
- Glass Turntable Diameter: 11 1/2"
- Vent Fan 300 CFM
- Vent Fan Control: High / Low / Off
- Cooktop Lighting: High / Low / Off

Warranty

One (1) Year All Parts and Labor
Ten (10) Years Parts Magnetron

Product Dimensions + Weight

Cavity Dimensions

(WxHxD) 19 5/16" x 9 5/8" x 14 3/8"

Unit Outside Net Dimensions

(WxHxD) 29 7/8" x 16 1/2" x 15 1/8"

Weight: 45.2 lbs / 20.5 kg

Shipping Dimensions + Weight

Dimensions: (WxHxD) 33 3/8" x 20 3/16" x 19 7/16"

Weight: 52.2 lbs / 23.7 kg

Color

- Stainless Steel
- White
- Black

Model

- SMH1622S
- SMH1622W
- SMH1622B

UPC Code

- 036725570559
- 036725570535
- 036725570542