



# NE595R1ABSR

## 5.9 cu. ft. Freestanding Flex Dual™ Oven

### Features

- Five Electric Ceramic Cooktop Elements
  - Two Dual Burners
  - Two Single Burners
  - Warming Center
- Dual Convection
  - Top: Fan Convection
  - Bottom: True Convection
- Large Oven Capacity – 5.9 cu. ft.
  - Top: 2.7 cu. ft.
  - Bottom: 3.0 cu. ft.
- SteamQuick™ (20 min. Oven Cleaning) and Self Clean
- Four Preset Menu Cook Options

### Convenience

- Hot Surface Indicator Light
- Auto Oven Light (2)
- Proofing
- Sabbath Mode
- Kitchen Timer
- Delay Start
- Child Safety Lock
- Self-Clean (2 / 3 / 4 hrs.)
- 4 Easy Cook Pre-Sets
- Custom Cook
- Defrost
- 2 Chrome Oven Racks



Easy to use cook top and oven with a 1.4 cu. ft. Storage Drawer.



Controls at your fingertips with an easy to read LED display.



Generous 5.9 cu. ft. cavity has more flexibility with a divider.

### Signature Features

#### Available Colors



Stainless Steel (shown)

#### Dual Convection

Convection fan in both chambers cooks food faster and more evenly.

#### Flex Duo Oven

The spacious 5.9 cu. ft. oven splits into two ovens with the Smart Divider to cook at two different temperatures at the same time.

#### Five Burner Cooktop

Boil water, simmer sauce or melt chocolate – there's a burner for your needs.

# NE595R1ABSR

## 5.9 cu. ft. Freestanding Flex Dual™ Oven

### Installing your Range

\* 30" minimum clearance between the top of the cooking surface and the bottom of an unprotected wood or metal cabinet; or 24" minimum when the bottom of the wood or metal cabinet is protected by not less than 1/4" flame retardant millboard covered with not less than no.28 MSG sheet steel, 0.015" stainless steel, 0.024" aluminum or 0.020" copper.

\*\* 15" minimum between the countertop and the adjacent cabinet bottom.

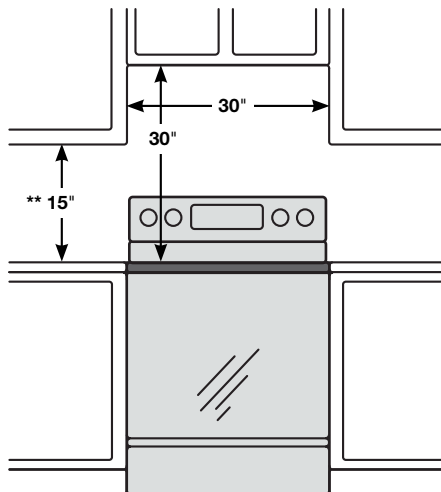

**IMPORTANT:** To eliminate the risk of burns or fire caused by reaching over heated surface units, cabinet storage space located above the surface units should be avoided. If cabinet storage is to be provided, the risk can be reduced by installing a range hood that projects horizontally a minimum of 5" beyond the bottom of the cabinets.

### Dimensions

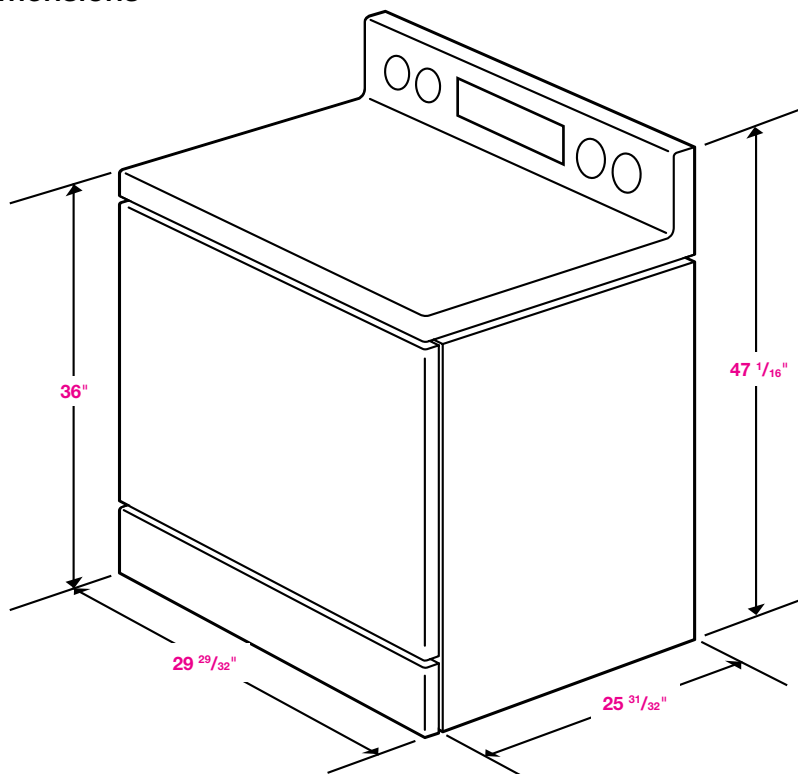

#### Power Source

240 V / 60 Hz

#### Induction/Radiant Ceramic Cooktop

- Right Front: Radiant 9 / 12", 3.0 KW – Fast Boil
- Left Front: Radiant 6 / 9", 3.0 KW – Fast Boil
- Right Rear: Radiant 6", 1.2 KW
- Left Rear: Radiant 6", 1.2 KW
- Center Rear: Warming Center, 100 W

#### Oven

- Hidden Bake Element: 3000 W
- Convection Bake: 150°F - 550°F
- Convection Roast: 150°F - 550°F
- Broil Element: 3800 W
- Convection Element/Heater: 1300 W
- Broil: Low / Hi (375°F - 450°F)
- Proofing
- Sabbath Mode

#### Warranty

One (1) Year All Parts and Labor  
Five (5) Years Electric Cooktop

#### Product Dimensions + Weight

##### Actual Oven Dimensions

(WxHxD) 25" x 20 25/32" x 18 15/16"

##### Outside Net Dimensions:

(WxHxD) 29 29/32" x 47 1/16" x 25 31/32"

Weight: 166 lbs / 75.3 kg

#### Shipping Dimensions + Weight

Dimensions: (WxHxD) 32 7/8" x 50 13/32" x 30 1/8"

Weight: 199 lbs / 90.3 kg

Color	Model #	UPC Code
Stainless Steel	NE595R1ABSR	036725570719