

NX58F5300SS

Gas Range

Features

- Large 5.8 cu. ft. Oven Capacity
- 52K BTU Total Power, including a 16K BTU power burner and 5K BTU simmer
- Continuous Matte Grates
- Black Enamel Cooktop
- Weighted Stainless Knobs
- Convenient Storage Drawer

Convenience

- Auto Oven Light
- Sabbath Mode
- Kitchen Timer
- Delay Start
- Auto Shut-Off Option
- Child Safety Lock
- Self Clean
- 3 Easy Cook Presets
- LP conversion kit included



Five Burner Cooktop



Large 5.8 cu. ft. Capacity

Available Color



Stainless Steel

Signature Features



Five Burner Cooktop

FIVE BURNERS FOR ULTIMATE FLEXIBILITY

- Enjoy the flexibility to cook with different-sized pans simultaneously.
- Whether you're boiling water, melting chocolate or simmering sauce, there's a burner for your needs: a high-power burner with 16K BTU, plus simmer, center and regular burners.



Large Capacity

5.8 CU. FT. OVEN ALLOWS YOU TO COOK MORE DISHES AT ONCE

- Easily accommodates a big roast, multiple casserole dishes or several racks of cookies.
- Two oven racks help you prepare enough food for large gatherings.

NX58F5300SS

Gas Range

Installing Your Range

30" minimum clearance between the top of the cooking surface and the bottom of an unprotected wood or metal cabinet; or 24" minimum when the bottom of the wood or metal cabinet is protected by not less than 1/4" flame retardant millboard covered with not less than no.28 MSG sheet steel, 0.015" stainless steel, 0.024" aluminum or 0.020" copper.

** 18" minimum between the countertop and the adjacent cabinet bottom.

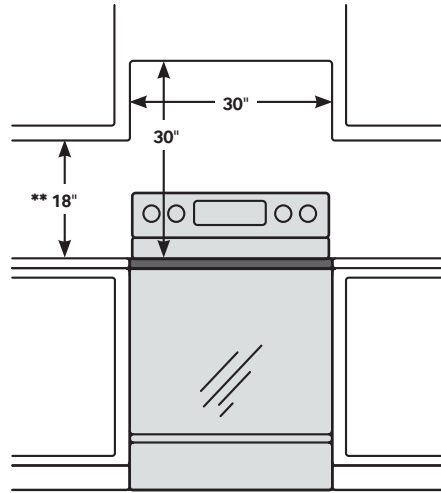

IMPORTANT: To eliminate the risk of burns or fire caused by reaching over heated surface units, cabinet storage space located above the surface units should be avoided. If cabinet storage is to be provided, the risk can be reduced by installing a range hood that projects horizontally a minimum of 5" beyond the bottom of the cabinets.

Dimensions

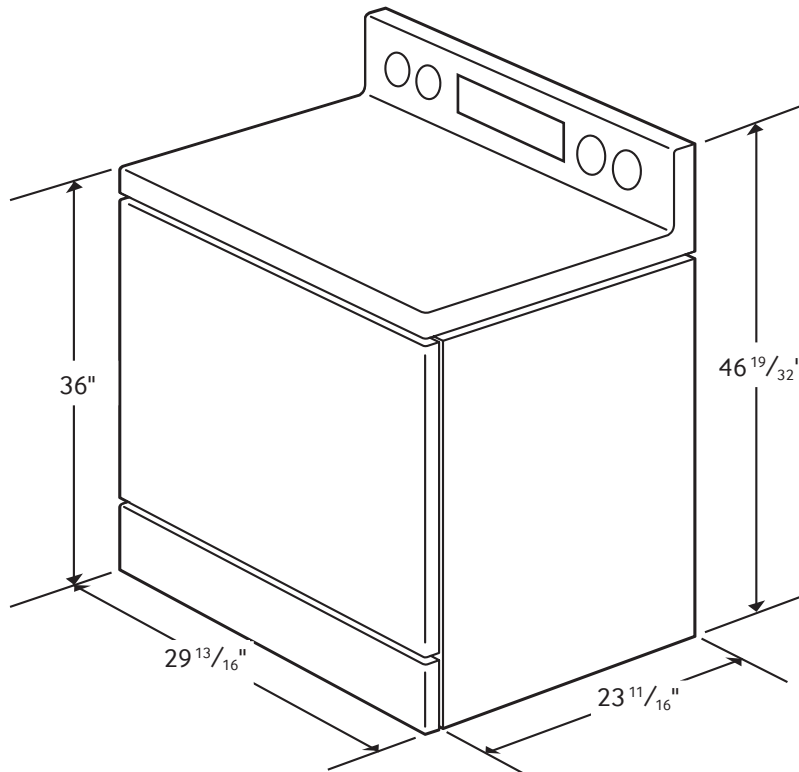

Total Power (BTU)
52K

Black Enamel 5 Burner Cooktop (BTU)

- Right Front: 16K
- Left Front: 12K
- Right Rear: 5K
- Left Rear: 9.5K
- Center (Round): 9.5K

Oven

- Capacity: 5.8 cu. ft.
- Bake: 150°F - 550°F
- Variable Broil: 375°F - 480°F
- Sabbath Mode

Storage Drawer

Capacity: 0.7 cu. ft.

Warranty

One (1) Year All Parts and Labor

Product Dimensions & Weight (WxHxD)

Outside Dimensions:
29¹³/₁₆" x 46¹⁹/₃₂" x 23¹¹/₁₆"

Weight: 188 lbs.

Shipping Dimensions & Weight (WxHxD)

Dimensions:
32⁷/₈" x 50⁹/₁₆" x 30¹/₈"

Weight: 210 lbs.

Color	Model #	UPC Code
Stainless Steel	NX58F5300SS	887276988207

SAMSUNG